

AMETEK MODEL 375 SUBMERSIBLE PRESSURE TRANSMITTER

Installation and Operating Instructions

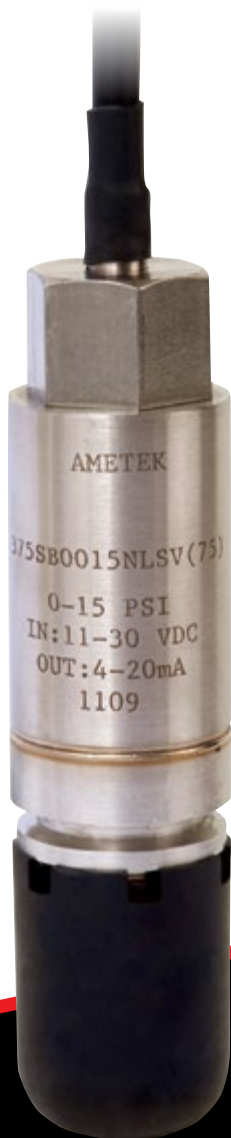

1" NPT Flush "F" Option for
Pipe or Vessel Mount



In-line desiccant
package to limit
moisture intrusion
(provided with psig reference units)





DESCRIPTION:

The Model 375 submersible level transmitter is specially designed to provide the convenience of direct submergence in many types of liquids for quick, accurate and reliable level measurement. The 375 provides an economical, lighter weight style for submersible level applications. The simple design and rugged construction of this solid state instrument provide long lasting service with virtually no maintenance.

The Model 375 indicates the level of liquid by continuously measuring hydrostatic pressure via its isolated sensing element, an ion implanted silicon semiconductor sensor. The standard output signal is 4-20 mA. For other input / output options, consult factory. This design provides for excellent linearity and repeatability, low hysteresis and long term stability at an economical price.

The Model 375 is easy to install; simply lower the sensor into a vessel or well. It's that easy. All the electronics are potted and mounted in a submersible 316 stainless steel housing. A special cable support bracket is also available. This gives extra stability to the transducer when used with longer lengths of cable (up to 2500 feet) or when used in an agitated liquid. A conduit adapter is also available.

A specially designed cable is factory installed and sealed to insure liquid tight performance. The customer connection end of the cable is sealed and a desiccant package is installed to limit the amount of moisture allowed to enter the barometric reference of the sensor.

The transducer is available calibrated for any span needed, from 6 psi (13.8 ft of water) to 300 psi (692 ft of water).

FEATURES:

- Potted electronics for robust moisture intrusion protection
- Low cost
- Solid state sensor for accuracy and reliability
- Lightweight and compact size
- Rugged 316 stainless steel housing with excellent environmental protection to IP68
- Advanced digital compensation
- Easy to install and use
- Vented to the atmosphere through the surface end of the cable (desiccant package supplied) with PSIG reference units
- Reverse polarity and surge protected
- 2 wire, 4 to 20 mA output standard; other low power voltage outputs available - consult factory
- Standard submersible model with nose cone; 1/4-18 NPT male with nose cone removed for pipe mount
- Flush 1" NPT process connection option for pipe or vessel mounting.

APPLICATIONS:

- Tanks
- Ponds
- Rivers
- Lakes
- Water wells
- Landfills
- Flood channels
- Pump control
- Lift stations
- Low power/solar applications



Specifications

Pressure Ranges: 0-6 psi to 0-300 psi

Accuracy at 25°C BFSL (Including Linearity, Hysteresis, Repeatability): 0.25% FS

1 Year Stability: < ±0.25% FS

Load Limitation: 600 OHM MAX (4-20MA), 50K OHM MIN (all voltage outputs)

Operating Temperature*:

Pressure Ranges up to 150 PSI: -25 to 60°C (-13 to 140°F)

Pressure Ranges above 150 PSI: -25 to 25°C (-13 to 77°F)

Compensated Temperature:

Pressure Ranges up to 150 PSI: 0 to 50°C (32 to 122°F)

Pressure Ranges above 150 PSI: 0 to 25°C (32 TO 77°F)

Total Error Band (Includes Temperature Effects, Zero and Span Sets): ±1% FS; 6 PSI range: ±2% FS

Burst Pressure: 3X FS or 450 PSI, whichever is less

Vibration: 10G, 55 – 2000 HZ

Shock: 30G

Wetted Materials: 316L stainless steel, polyurethane cable, Viton / Neoprene seal, Delrin

Process Connection: 1/4 -18 NPT male with a protective Delrin snubnose removed

Electrical Connection: #22 AWG cable with options N, R, C include potted end, vent tube and in-line desiccant canister

Pressure Code:

0006 – 0-6 PSI (0-0.4 BAR), 13.8 feet water (4.2 m)

0015 – 0-15 PSI (0-1 BAR), 34.6 feet water (10.5 m)

0030 – 0-30 PSI (0-2 BAR), 69.2 feet water (21.1 m)

0060 – 0-60 PSI (0-4 BAR), 138.4 feet water (42.2 m)

0100 – 0-100 PSI (0-7 BAR), 230.7 feet water (70.3 m)

0150 – 0-150 PSI (0-10 BAR), 346.1 feet water (105.5 m)

0300 – 0-300 PSI (0-21 BAR), 692 feet water (211 m)

Other ranges are available – please consult factory.

** Do not subject unit to freezing water, or damage may result.*

For unspecified pressure ranges, errors are based on turndown of the next higher range.

Affected specifications include 1 year stability and total error band.

Example: 9 PSI range is (15 PSI sensor ÷ 9 PSI range) X 1% = 1.67% total error band.

CONDUCTOR COLOR	VOLTAGE OUTPUT	CURRENT OUTPUT
red	+Vin	+Vin
black	-Vin	-Vin
white	Vout	N/A
green	case ground	

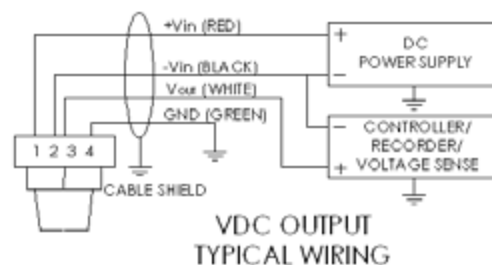
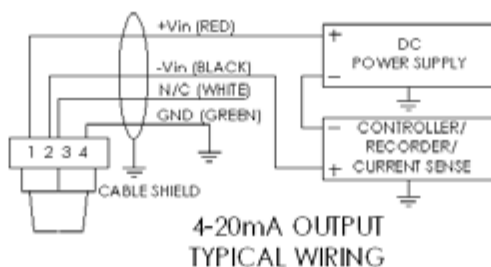

NOTE: Cable shield tied to case for EMI options



Dimensional Drawings

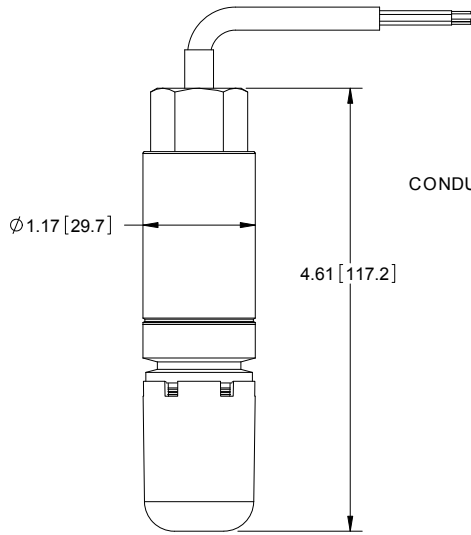

CABLE OUTPUT
(WITHOUT DESICCANT)
SCALE=1:1

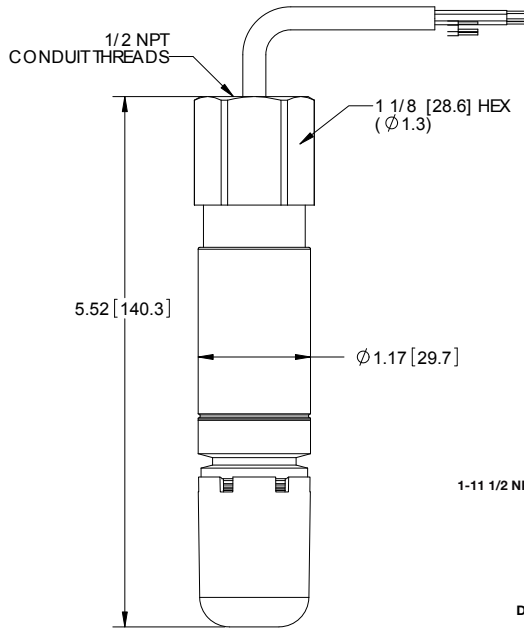

CONDUIT OPTION
(WITHOUT DESICCANT)
SCALE=1:1

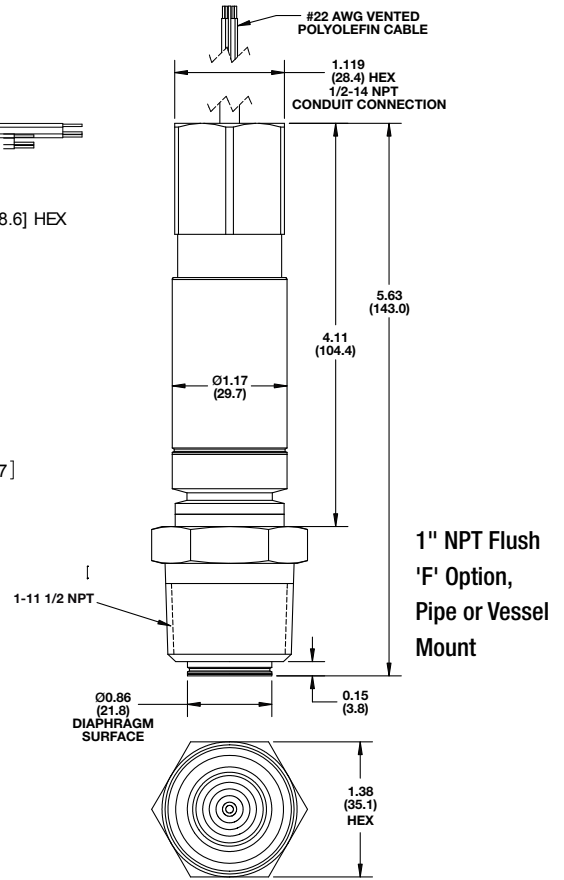

1" NPT Flush
'F' Option,
Pipe or Vessel
Mount

CABLE SUPPORT OPTION
SCALE=3:4

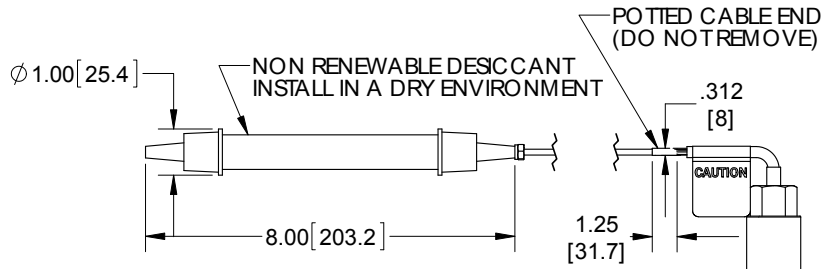
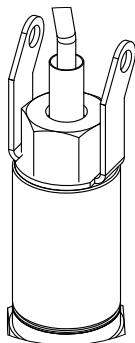

CABLE OPTIONS N, R, C
WITH DESICCANT CANISTER
(GAUGE REFERENCE MODELS ONLY)
SCALE=3:8



Model 375 Transmitter Installation



WARNING: Remove power before installing or servicing.

To install the Model 375 Transmitter, connect the surface end of the cable to the Ametek Model DDMC Meter Controller or other power source and indicator. Suspend the transmitter into a well or tank supported only by its attached shielded electronic cable. Insure that the opening in the well or tank cover is large enough for possible future removal of the transmitter.

Additional support to the transmitter is available with an optional factory installed cable support. The optional cable support is recommended when using longer lengths of cable or when suspending the transmitter into agitated liquids. The cable support provides strain relief for the excess stress found under these circumstances. See diagram of Model 375 Transmitter with cable support using optional factory or customer supplied and installed support cable.

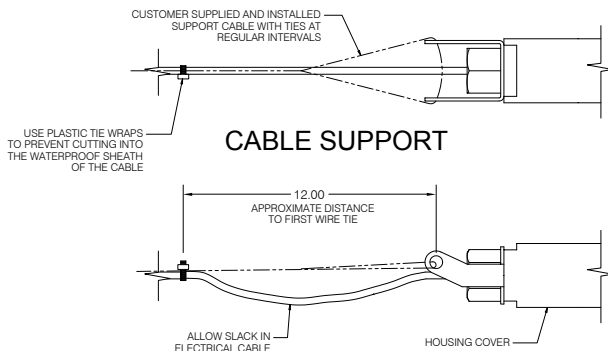

Surge or lightning protectors are available as optional items and are strongly recommended for protection from secondary surges or lightning strikes. The units are easy to install, are maintenance-free and respond in less than one nanosecond. Install in accordance with the instructions:

1. Lightning protection devices should be placed as close to the instrument as possible and wired in accordance with National Electric Code in an approved watertight enclosure.
2. If the distance between the meter and transmitter, or the meter and recorder is less than 100 feet, only 1 protector per line may be used.
3. Use No. 10 AWG ground wire or better from protector to earth ground.
4. Provide a separate ground for each run of shielded cable or metal conduit.



CAUTION: The cable grommet and support are specially installed by factory-trained personnel to insure water-tightness. Any adjustment or removal of these items may destroy the watertight feature thus exposing the transmitter to water seepage, an electrical short and transmitter failure. Any adjustment or removal of the cable grommet or cable support voids the warranty.



CAUTION: Waterproof cable should not be kinked or nicked. Do not cut off excess cable. This will remove the sealed cable end, void the warranty and allow water into the electronics housing. Permanent damage will result. (Never cut or splice the waterproof cable). The surface end of the cable is used as the system's atmospheric reference. This end is factory sealed and venting occurs through a small tube. The tube should be connected to the desiccant kit provided with the transmitter. It is recommended that this be installed in a dry, temperature stable environment.

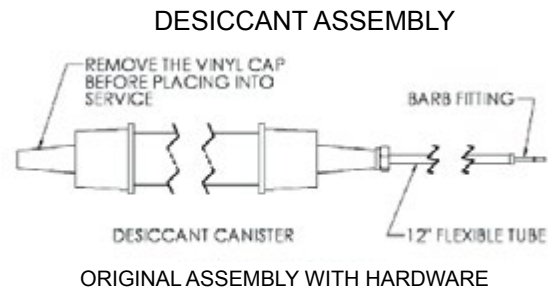

5. Keep the ground wire less than 1 foot long and tie to a suitable ground rod or metal frame ground. Surge capability is only as good as the grounding method. All ground connections must be installed.
6. Install all protectors in weathertight enclosures.
7. Run signal lines shielded and away from power lines.
8. Wire according to the Electrical Code.
9. When used for an intrinsically safe installation, only one LMA912 should be installed in the hazardous location. Do not substitute protector types.



CAUTION: This or any installation cannot protect against a direct lightning strike, or secondary strikes of sufficient magnitude. Ametek cannot accept liability for damage due to lightning or secondary surges.



Model Numbering

- 375 Submersible Level Transmitter

375 Submersible Level Transmitter

- Sensing Port

- S Delrin snubnose (standard)
- M Metal snubnose
- N No snubnose, 1/4 - 18 NPT male
- F 1" NPT flush diaphragm

- Input / Output (Consult factory for more options)

- B 11 to 30 VDC / 4 to 20mA (standard)
- D 9 to 30 VDC / 1 to 5 VDC

- Pressure Ranges Standard (Consult factory for other ranges)

PSI	BAR	Reference Equivalents	
0006	B0.4	0-13.8 ft. water	0-4.2 meters water
0015	B001	0-34.6 ft. water	0-10.5 meters water
0030	B002	0-69.2 ft. water	0-21.1 meters water
0060	B004	0-138.4 ft. water	0-42.2 meters water
0100	B007	0-230.7 ft. water	0-70.3 meters water
0150	B010	0-346 ft. water	0-105.4 meters water
0300	B021	0-692 ft. water	0-211 meters water

- Electrical Connection** (Consult factory for more options)

- N 22 AWG polyurethane vent tube cable (K515072) / nut
- R 22 AWG polyurethane vent tube cable (K515072) / nut / cable support bracket
- C 22 AWG polyurethane vent tube cable (K515072) / conduit adapter

- Diaphragm Material

- L 316L stainless steel (standard)

- Fill fluid

- S Silicone oil (standard)

- Cable Seal

- V Viton® (standard)
- N Neoprene

- Cable Length

Must be specified in feet

375

S

B

0006

N

L

S

V

50

*Standard units are psig reference, but psia and psis reference available – consult factory.

**Options N, R, and C include desiccant filter.

Consult factory for temperature measurement option availability.

CABLE SUPPORT OPTION

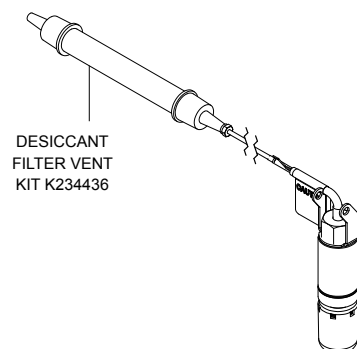
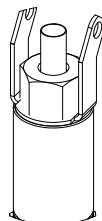

DESICCANT FILTER VENT KIT K234436



Service & Accessories

FACTORY SERVICE

Factory or field service is available by contacting the Customer Service Department. Supply the following information:

- 1) Instrument Model Number and Serial Number as shown on the Instrument Data Tag.
- 2) Description of problem being experienced.
- 3) Description and location of the installation.

Phone: (215) 674-1234

Email: mctpmt.sales@ametek.com

PARTS / ORDERING

When ordering replacement parts, supply the following information:

- 1) Part description and part number.
- 2) Quantity of each item required.
- 3) Shipping instructions and address.

Mail, Telephone, or Email Orders to:

AMETEK STC, PMT PRODUCTS

205 Keith Valley Rd., Horsham, PA 19044

Phone: (215) 674-1234

Email: mctpmt.sales@ametek.com

Webpage: www.ametekusg.com

ACCESSORIES / PARTS

LMA 912	30 VDC SURGE / LIGHTING PROTECTOR Protects the excitation and signal lines between an Ametek Model DDMC Meter Controller, or other power source and indicator, and the Model 375 4-20mA output transducer.
DDMC	Meter/ controller, power supply (120-240VAC input), various options available, consult factory
K515183	1/16" Diameter Stainless Steel Support Cable
K234436	Disposable in-line desiccant – original assembly with hardware
K234446	Replacement desiccant cartridge ONLY – requires some assembly of parts from original assembly



Warranty Policy

Ametek ["Seller"] warrants these products for a period of one year from the date of shipment that all products manufactured by the seller are free from defects of material and workmanship when used within the service, range, and purpose for which they were manufactured. Seller will, at its option, repair, replace, or refund the purchase price of parts found by Seller to be defective in material or workmanship provided that written notice of such defect requesting instructions for repair, replacement, or refund is received by Seller at the address below within the warranty period and provided that any instructions thereafter given by Seller are complied with.

This warranty shall not apply (i) to the performance of any system of which Seller's products are a component part, (ii) to deterioration by corrosion or any cause of failure other than defect of material or workmanship, or (iii) to any of Seller's products or parts thereof which have been tampered with or altered or repaired by anyone except Seller or someone authorized by Seller, or subjected to misuse, neglect, abuse or improper use or misapplication such as breakage by negligence, accident, vandalism, the elements, shock, vibration, or exposure to any other service, range, or environment of greater severity than that for which the products were designed.

SELLER MAKES NO WARRANTY OF ANY KIND, EXPRESS OR IMPLIED. INCLUDING WITHOUT LIMITATION ANY WARRANTIES OF FITNESS OR OF MERCHANTABILITY WITH RESPECT TO ITS PRODUCTS, OR ANY PART THEREOF, OTHER THAN AS EXPRESSLY SET FORTH ABOVE. NOR SHALL SELLER HAVE INCURRED ANY OTHER OBLIGATIONS OR LIABILITIES OR BE LIABLE FOR ANY ANTICIPATED OR LOST PROFITS, INCIDENTAL DAMAGES, CONSEQUENTIAL DAMAGES, TIME CHARGES, OR ANY OTHER LOSSES INCURRED IN CONNECTION WITH THE PURCHASE, INSTALLATION, REPAIR, OR OPERATION OF ITS PRODUCTS (INCLUDING ANY PARTS REPAIRED OR REPLACED.)

This warranty does not extend to anyone other than the original Buyer from the Seller.