



ELECTRONIC PRESSURE MEASUREMENT PRODUCTS

Model 575 Series Submersible Level Transmitters with NSF Approval



DESCRIPTION

The Model 575 with NSF Approval is used for clean water applications including potable water storage, livestock tanks and municipal water treatment. The sensor is designed to provide the convenience of direct submergence in many types of liquids for quick, accurate and reliable measurement. With stainless steel isolation diaphragm (standard) and all 316 stainless steel housing, these solid state instruments provide long lasting service with virtually no maintenance.

The transmitter is offered in a standard non-clogging snub nose end, in Nylon and SST. The 575 series is CSA approved for intrinsically safe operation when used with an approved safety barrier.

The 575 Series transmitters indicate the level of liquid by continuously measuring hydrostatic pressure via its sensing element, an ion implanted silicon semiconductor chip with integral Wheatstone bridge circuit. The pressure measurement is transmitted by a 4-20 mA output signal. This design, with isolation diaphragm for media compatibility, provides for excellent linearity and repeatability, low hysteresis and long term stability with a precision accuracy at $\pm 0.25\%$ FS (BFSL) typical.

The transmitter is easy to install. Simply lower the unit into a tank, pond or vessel. All electronics are mounted in the submersible 316 stainless steel housing. A special cable support bracket is also available to provide extra stability when used with longer cable lengths or when used in an agitated liquid. Optional steel support cable is also available for use with the support bracket.

The transmitters are available calibrated for any span needed from 0-6 psi (0-13.8 ft of water, 0-.4 bar, 0-4.2 meters of water) to 300 psi (0-692 ft of water, 0-20 bar, 0-211 meters of water). The transducer is offered as a standard 2 wire, 4-20 mA device.

To complete your liquid measurement and control system, consider the Model DDMC meter/controller or the complete Levelmate III system.

The 575 transducer is manufactured in the United States under ISO 9001 and meets ARRA.

FEATURES

- NSF approved
- Low cost measurement solution, easy installation and precision accuracy
- Rugged 316 stainless steel construction and wetted materials resists the corrosive effects of caustic medias with excellent environmental protection, designed for continuous submersion
- 2 wire, 4 to 20 mA output
- Reverse polarity and surge protected with additional lightning and surge protectors
- CSA approved for intrinsically safe operation in hazardous areas in Canada and U.S.
- Desiccant available to minimize moisture effects
- Designed for continuous submersion
- Made in USA



APPLICATIONS

- Inventory tank measurement
- Livestock tanks
- Ponds, rivers and lakes
- Municipal water treatment
- Water wells
- Pump control



Model 575S
standard 1/2 NPT
(with nose cone removed)



ELECTRONIC PRESSURE MEASUREMENT PRODUCTS

Model 575 Series Submersible Level Transmitters with NSF Approval

SPECIFICATIONS

Feet of Water: 0/14, 0/35, 0/69, 0/138, 0/230, 0/345, 0/460, 0/690

Meters of Water: 0/4, 0/10, 0/21, 0/42, 0/70, 0/105, 0/140, 0/210

Bar: 0/0.4, 0/1, 0/2, 0/4, 0/7, 0/10, 0/14, 0/20

PSI: 0/6, 0/15, 0/30, 0/60, 0/100, 0/150, 0/200, 0/300

Output: 4 to 20 mA, 2 wire, current limited to 30 mA DC

Power Supply: 12 to 40 VDC with reverse polarity surge protection; limited to 28 VDC for CSA I.S.

Loop Resistance: 1400 ohms maximum at 40 volts

Temperature Range:

General Ambient Operating: -25 to 180°F (-32 to 82°C)**

** CSA intrinsically safe when connected per AMETEK drawing BK750535. Temperature code T3C ambient high temperature limit (Tamb) = 104°F (40°C) max.

If submerged in a liquid that has frozen, damage will result

Storage: -40° to 180°F (-40°C to 82°C)

Overrange Effect: ±0.15% full scale at 200% of maximum range

Overrange Limit: 200% of maximum range

Accuracy: ±0.25% full scale, BFS (including linearity, hysteresis and repeatability); ±0.50% full scale (6 psi range only)

Zero Offset: ±0.50% full scale set at 77°F (25°C)

Span: ±0.50% full scale set at 77°F (25°C)

Temperature Effects: (15 psi and above)

Compensated: 23° to 130°F (-5°C to 55°C); maximum ±1% URL output change for ±25°C temperature change within compensated range when calibrated at 25°C

Consult factory for lower or alternate pressure ranges.

Power Supply Effect: ±0.005% full scale per volt

Construction:

Diaphragm: 316 stainless steel 575 S and M models

Housing Type: 316 stainless steel

Nut/Washer Type: 316 stainless steel

Cable Grommet: Viton standard

Housing O Ring: Viton standard

Cable Jacket: Polyurethane (standard)

Media Compatibility: Reference materials of construction

Electrical Connection: Attached 20 gauge polyurethane shielded cable (standard); unspliced lengths available up to 700 feet / 213 meters

Consult control drawing or contact the factory for cable length limits for Intrinsically Safe (I.S.) use.

Weight: 1 lb. (454 g) model 575S

Approvals: Meets NSF/ANSI/CAN 61 and NSF/ANSI 372. Meets CSA requirements for intrinsically safe operation in hazardous locations as designated by Class I, Div 1, Groups A, B, C & D and Class II, Groups E, F & G. Temperature Code T3C (when used with approved barrier) All NSF approved units will have X459 at the end of the sensor part number.

Snub Nose: Nylon 6/6 or optional 316 stainless steel; removable to a 1/2" female NPT process connection

Calibration:

NOTE: Units are calibrated 4-20 mA over standard full scale range unless otherwise specified

Examples:

Model 575SB0015NLSX459 will be calibrated as 4 mA = 0 psi, 20 mA = 15 psi or 4-20 mA over 0-34.6 ft. of water

For a special calibration select the appropriate standard pressure range and indicate the special calibration as follows:

Model 575SB0015NLSX459 Calibrate 0-10 psi or calibrate 0-23 ft. of water





ELECTRONIC PRESSURE MEASUREMENT PRODUCTS

Model 575 Series Submersible Level Transmitters with NSF Approval

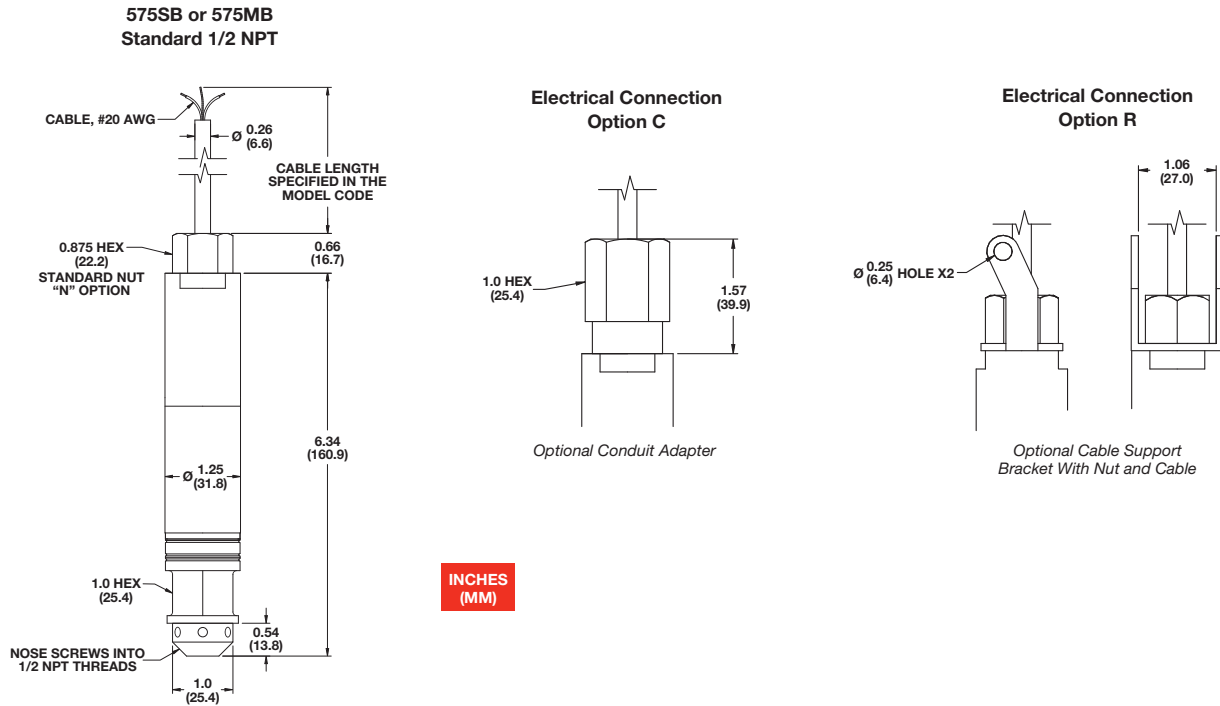



ELECTRONIC PRESSURE MEASUREMENT PRODUCTS

Model 575 Series Submersible Level Transmitters with NSF Approval

Model Numbering:			
● 575 level transmitter			
575 Series submersible level transmitter			
● Sensing port			
S	Nylon snub nose (standard)		
M	Stainless steel snub nose		
● Input/Output*			
B	12 to 40 VDC / 4 to 20 mA		
● Pressure ranges**		● Reference equivalents	
PSI	BAR		
0006	0.4B	0-13.8 ft. water	0-4.2 meters water
0015	001B	0-34.6 ft. water	0-10.5 meters water
0030	002B	0-69.2 ft. water	0-21.1 meters water
0060	004B	0-138 ft. water	0-42.2 meters water
0100	007B	0-230 ft. water	0-70.3 meters water
0150	010B	0-345 ft. water	0-105.4 meters water
0200	014B	0-460 ft. water	0-140.6 meters water
0300	020B	0-690 ft. water	0-211 meters water
● Electrical connection			
N	Polyurethane cable w/ nut (standard)		
R	Polyurethane cable w/ nut and cable support bracket		
C	Polyurethane cable w/ conduit adapter		
● Diaphragm material			
L	316 stainless steel (standard)		
● Fill fluid			
M	Mineral oil		
● NSF Approval			
X459	NSF 61 and NSF 372 approved sensor		
● Cable length (specify in feet)*** Enter as separate line item			
K515076	Polyurethane (standard)		
575	S	B	0015
	N	L	M
		X459	(100 feet of cable – K515076)

* Please contact the factory for availability of different input / output options

** Calibrated ranges can be specified after the model code; the specific range should be between the upper and lower ranges in the category selected

*** All NSF approved units will be shipped with cable installed at the factory. Maximum cable length is 700 feet / 213 meters. Please contact factory for other options



OPTIONS AND ACCESSORIES

Display Meters, Surge Protectors, Junction Boxes and Desiccants

DISPLAY METERS AND SYSTEMS

Model DDMC Digital Meter/Controller

Dual display meter provides power to the sensor with alarm and 4-20 mA analog output options. Standard panel mount housing or a NEMA 4X weathertight housing for field mounting is available. The weathertight housing also provides internal mounting locations for lightning and surge protectors.



LEVEL MATE™ III Level Measurement System

The complete LEVEL MATE III system includes a level sensor (various models are available), cable and a meter/controller all packaged in a NEMA 4X enclosure. Everything is factory programmed for easy installation and the LEVEL MATE III has an extended 2-year warranty.

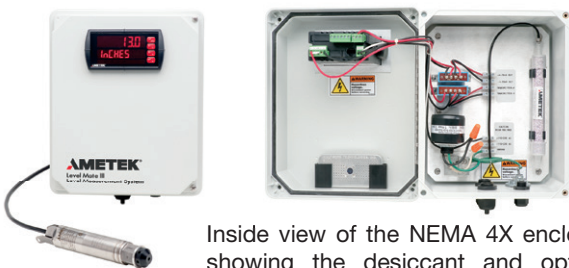

Inside view of the NEMA 4X enclosure showing the desiccant and optional surge protectors. Unit is factory wired so that the user needs to connect power and sensor only.

LIGHTNING AND SECONDARY SURGE PROTECTORS

Lightning protection units are available to help protect systems and components from lightning and secondary surges. These LP units are available in both 30 VDC (LMA912) for 24 VDC supply on excitation/signal lines and analog meter output lines to protect the meter and/or the transmitter as well as 115 VAC (LMA918) and 230 VAC (LMA919) to protect the meter on AC power input lines.

JUNCTION BOXES

Model SBJ100 with Reusable Desiccant

These boxes are used on long cable runs and provide quicker access to atmospheric reference. SBJ100 provides a clean, dry enclosure with an internal, reusable desiccant canister.

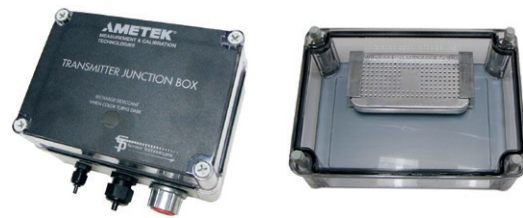

Back view of SBJ100 junction box that shows the reusable desiccant canister.

DESICCANTS

An initial desiccant is supplied with the SBJ100 and the LEVEL MATE III enclosure. The desiccant canister is reusable with visible color change when the time comes to replace the desiccant.

