



PMT PRODUCTS

MODEL 675

Shark Cage

Intrinsically Safe  **Submersible Level Transmitter**

INSTRUCTIONS FOR INSTALLATION AND OPERATION



Contents

Section 1: Introduction	1
1.1 System Description	1
1.2 Model Number	2
Section 2: Installation	3
2.1 Safety Information	3
2.2 Unpacking & Inspection	3
2.3 Operational Checkout.....	3
2.4 Mounting	4
2.5 Wiring	6
2.6 Cable Termination.....	8
Section 3: Accessories	10
3.1 Parts & Accessories.....	10
3.2 Ordering Parts & Accessories	10
Section 4: Troubleshooting	11
4.1 Problem/Cause/Checks	11
4.2 Factory Assistance	11
4.3 Equipment Return.....	12
Section 5: Specifications	14
5.1 Model 675 Series Transmitter	14
Section 6: Drawings	15
6.1 Intrinsic Safety	15
6.2 Outline Drawings	16

AMETEK STC makes no warranty of any kind with regard to the material contained in this manual, including, but not limited to, implied warranties or fitness for a particular purpose. STC shall not be liable for errors contained herein or for incidental or consequential damages in connection with the performance or use of material.

Section 1: Introduction

1.1 System Description

The Model 675 is specifically designed for slurry and highly viscous applications where clogging of the sensor area is common. The Model 675 uses a 3.5" flush diaphragm to prevent unwanted clogging of the sensing area. This submersible level device is made of 316 SS which offers outstanding environmental protection and is available in depths up to 138 feet of water.

The non-fouling flush diaphragm is designed to eliminate unwanted buildup of debris, fats, oils, greases, and other bio-solids by removing any potential gaps on the measurement area. The high integrity seal's heavy construction eliminates the effects of turbulence on the sensor.

The 675 Series Transmitters indicate the level of liquid by continuously measuring hydrostatic pressure via its sensing element, an ion implanted silicon semiconductor chip with integral Wheatstone Bridge circuit. Once the sensor measures the pressure, the data is transmitted by a 4 to 20 mA output signal. This design provides for excellent reliability in remote and inaccessible locations.

The Model 675 is approved for intrinsically safe operation in hazardous locations as designated by Class I, Div 1, Groups A, B, C & D and Class II, Groups E, F & G. when connected per Ametek drawing BK750535.

All Model 675 transmitters are equipped with a sealed cable termination area and moisture absorbing desiccant canister. The purpose is to restrict moisture from entering the transmitter through the cable vent.

Features

- Oversized 4.75" flush diaphragm to prevent clogging
- 0.25% Full Scale Accuracy
- Intrinsically Safe for Class 1 Division 1 Applications
- Custom Pressure Ranges and Cable Lengths
- Extremely rugged 316L SS construction
- Two-wire, 4-20 mA standard output
- Reverse polarity and surge protection

Applications

- Lift Stations
- Sewage Levels
- Slurries
- Storm Runoffs
- Pump Control

Model 675 Series Submersible Level Transmitter

1.2 Model Number

Model Numbering

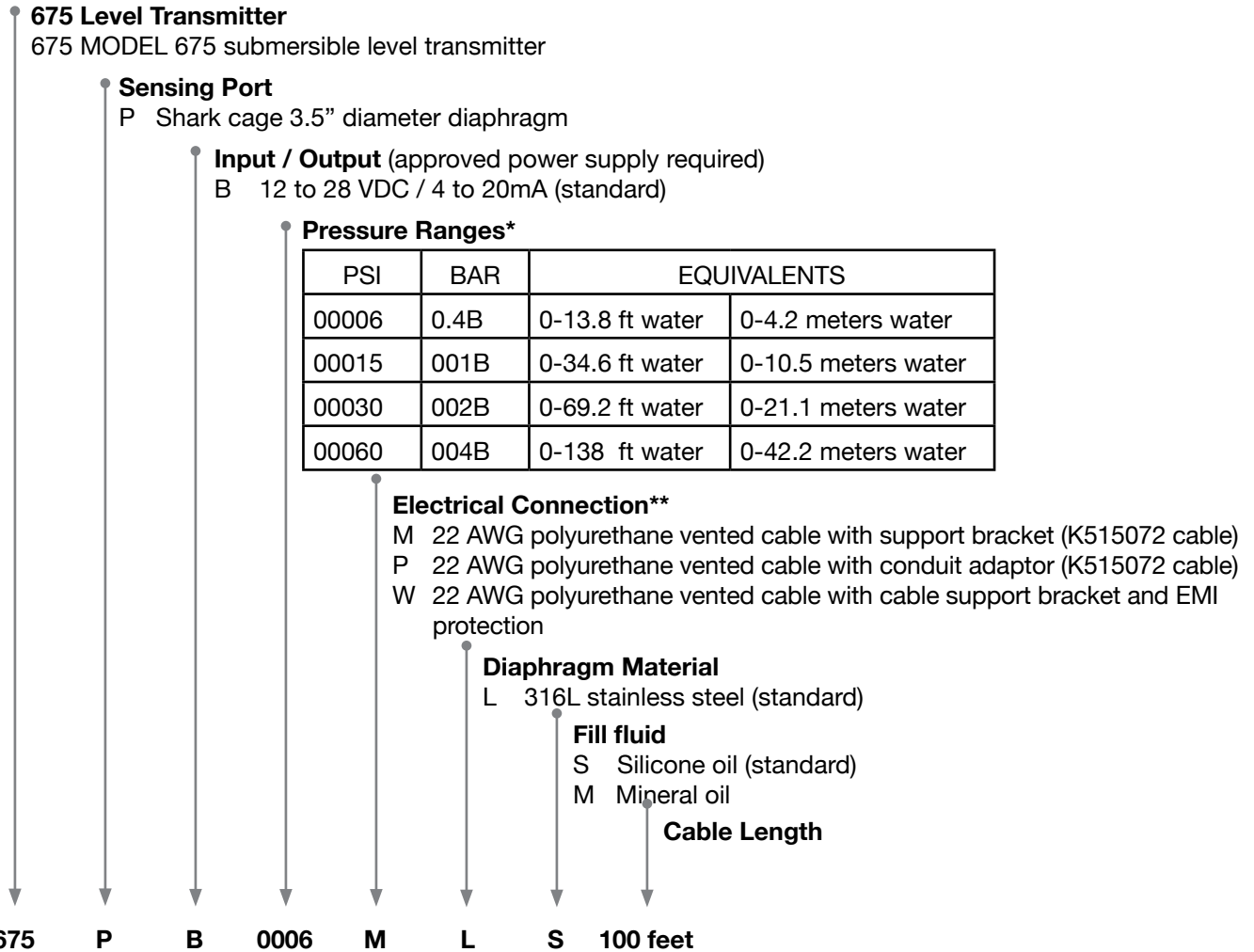

*Decimal points for non-standard ranges may be used
 Decimal point requires one model code position, i.e. 1.08 = 4 positions

Section 2: Installation

2.1 Safety Information



The overall system is designed to prevent accidental shock to the operator when properly used. No design, however, can insure the safety of an instrument improperly installed or used negligently. Read this manual carefully and completely before operating the instrument. Failure to read this manual in its entirety could result in damage to the instrument or injury to the operator.

To avoid possible shock hazard install in a grounded enclosure, prevent live parts being touched and ground the sensor sheath and housing. Follow wiring diagrams and local regulations. Installations where failure of this equipment may cause personal injury, property loss, equipment damage or financial loss, backup failsafe protection must be used.

2.2 Unpacking & Inspection

Carefully remove the contents of the shipping carton and check each item against the packing list before destroying any packing material. If there is any shortage or damage, report it to the factory immediately.

When this transmitter is used with the AMETEK PMT Products DDMC Controller, the transmitter Model Number is identified on the nameplate of the DDMC in the section labeled “USED WITH.” This is because the DDMC is calibrated with, and should be used only with a specific Submersible Transmitter. Look for a correlation between the two instruments.

2.3 Operational Checkout

Before installing the 675 Series Transmitter, make sure the system is operating by doing a bench check.

WARNING:



Do not connect any wires while Power is applied.

For temporary connections, refer to diagrams in Wiring Section 2.5 of this manual. Connect AC power to the controller and/or with which it is to be used. Apply power and allow a five-minute warm-up.

With no pressure applied to the transmitter, the meter should display zero (or for “drawdown” the reading corresponding to the depth below ground level that the transmitter will be when installed.)

Model 675 Series Submersible Level Transmitter

2.3 Operational Checkout (continued)



CAUTION: Do not simulate an increase in pressure by applying mechanical force to the sensing diaphragm of the transmitter. Excessive force will result in damage to or destruction of the transmitter.

When pressure is applied to the transmitter, the display should increase, and then return to the original reading when pressure is removed. The Transmitter can be pressurized by lowering it into water or by applying air pressure from a calibration device.

2.4 Mounting

2.4.1 Dimensions

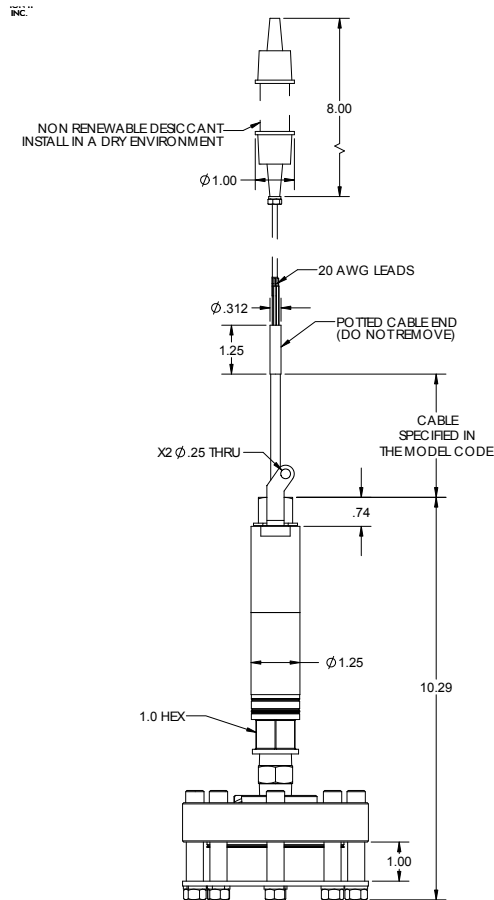
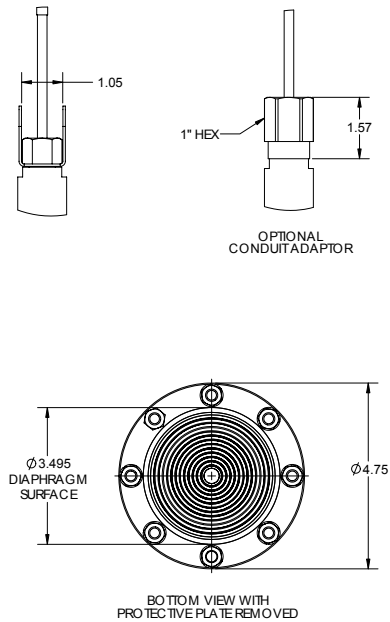

2.4.2 Placement

The Model 675 Transmitter should be supported by customer-installed strain relief cable that is attached to the tabs on the transmitter or optional factory stainless steel support cable #K515183. Reference Figure 2-2 for installation recommendations. Ametek does not recommend suspending the transmitter supported only by its attached electrical cable.



Caution: Do not allow transmitter to remain in liquid when it freezes solid. This will apply mechanical force to the sending diaphragm of the transmitter. Excessive force will result in transmitter damage or destruction.

2.4.3 Model 675 Series Transmitter



CAUTION: The cable grommet is specially installed by factory-trained personnel to assure that it remains watertight. Any adjustment or removal of the grommet may destroy the watertight feature thus exposing the transmitter to water seepage, causing an electrical short and transmitter failure. Any adjustment or removal of the cable grommet voids the warranty.



CAUTION: The diaphragm seal assembly is installed by factory trained personnel and should not be modified in the field. Any adjustment or removal of the diaphragm seal assembly voids the warranty.



CAUTION: The waterproof cable should not be kinked or nicked, which will allow water to seep into the cable and short out the transmitter.

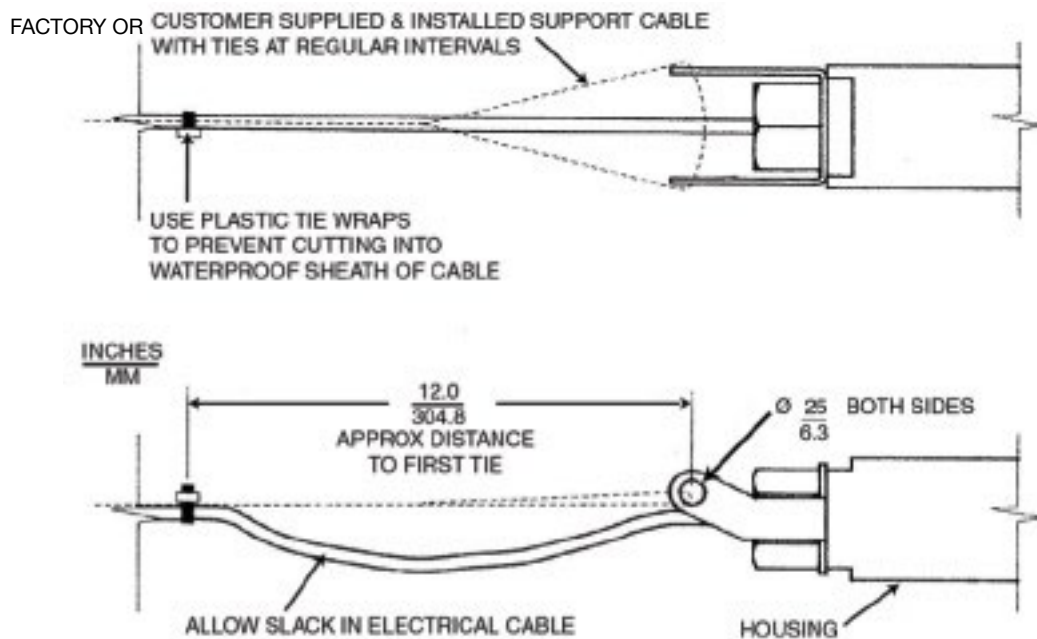

Figure 2-2
Transmitter Installation Considerations

2.4.4 Provide Signal Noise Isolation

The transmitter should not be mounted close to high current switching relays or in an enclosure containing such relays. Low voltage wiring (transmitter signal wires and analog output wires) should be separated from high voltage wiring (115, 230 & 440 Vac) and should be shielded.

2.5 Wiring



WARNING:

Do not connect any wires while AC Power input is applied.

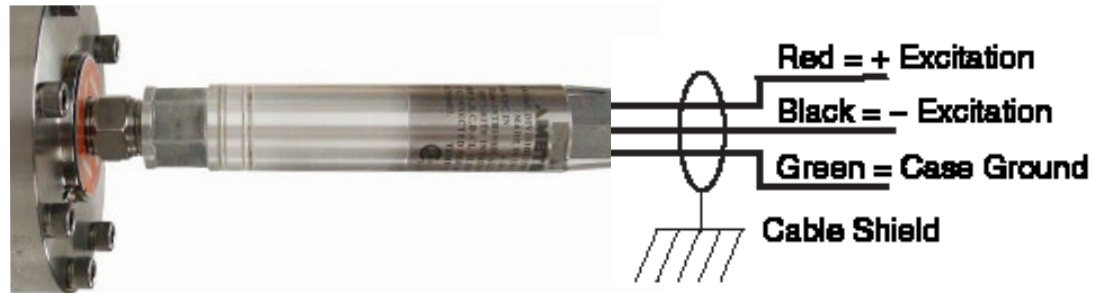

Figure 2-3
Transmitter Wiring Identification

2.5.1 Surge Protection

Surge protectors are available as an option item (see Parts & Accessories in Section 3 of this manual). It is strongly recommended to protect from secondary surges and lightning on outdoor installations. Install in accordance with the applicable drawing that is supplied with the surge protector and the following instructions:

1. Lightning protection devices should be placed as close to the meter or transmitter as possible and wired in accordance with Local Electrical Codes in an approved watertight enclosure.
2. If the distance between the meter and transmitter, or meter and recorder is less than 100 ft., only one protector per line is needed.
3. Use No. 8 AWG ground wire or better from protector.
4. Keep ground wire less than one foot long and tie to a suitable ground rod or metal frame ground. Surge capability is only as good as the grounding method. **All ground connections must be installed.**
5. Install protectors in weather-tight enclosures.
6. Run signal lines shielded and away from power lines.
7. Mount the fused switch panel as close to the meter as possible. Wire according to the Local Electrical Code.
8. Lead lines for 110 Vac and 220 Vdc protectors should be cut as short as practical.



2.5.1 Surge Protection (Continued)



CAUTION: This or any installation can not protect against a direct lightning strike, or secondary strikes of sufficient magnitude. AMETEK PMT Products cannot accept liability for damage due to lightning or secondary surges.

2.5.2 Lightning Protection Wiring

Here is a typical wiring arrangement to a typical controller/ meter. Shown here are connectors to the AMETEK PMT Products DDMC Controller in the Levelmate III NEMA 4X enclosure option.

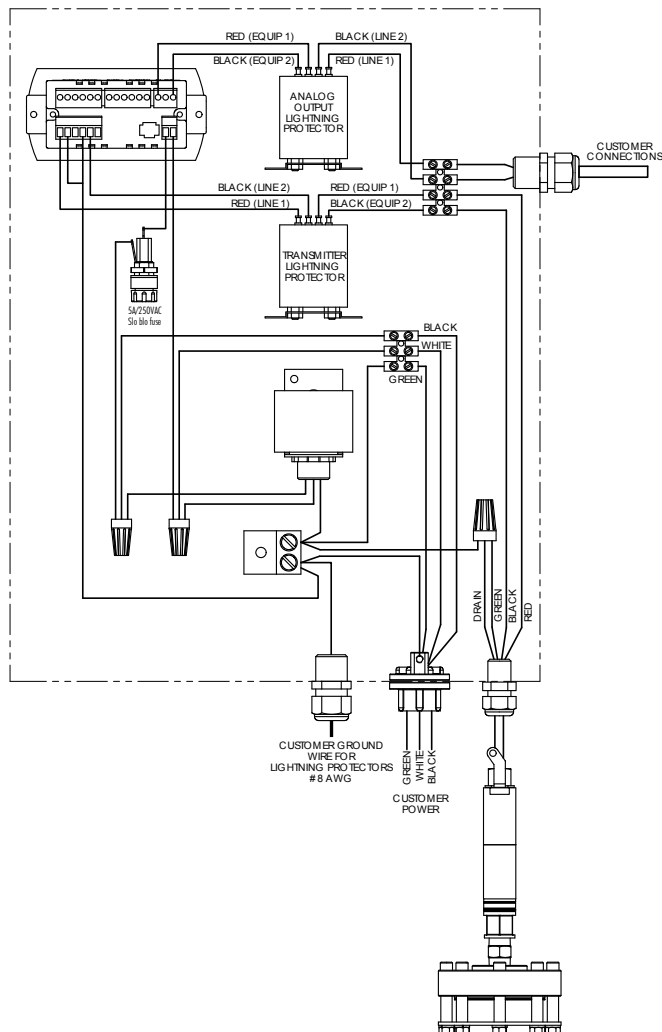

Figure 2-4
Wiring with Lightning Protection Options

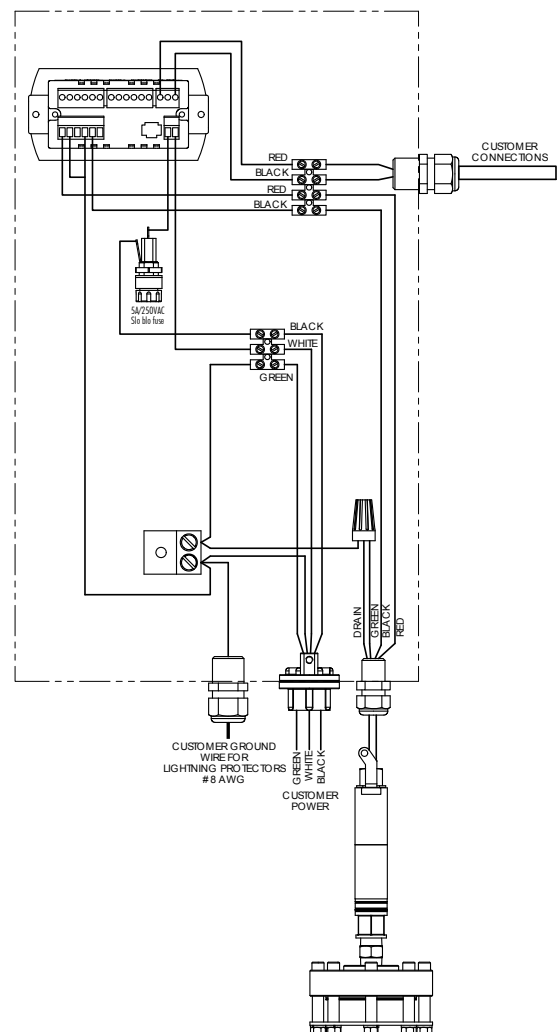
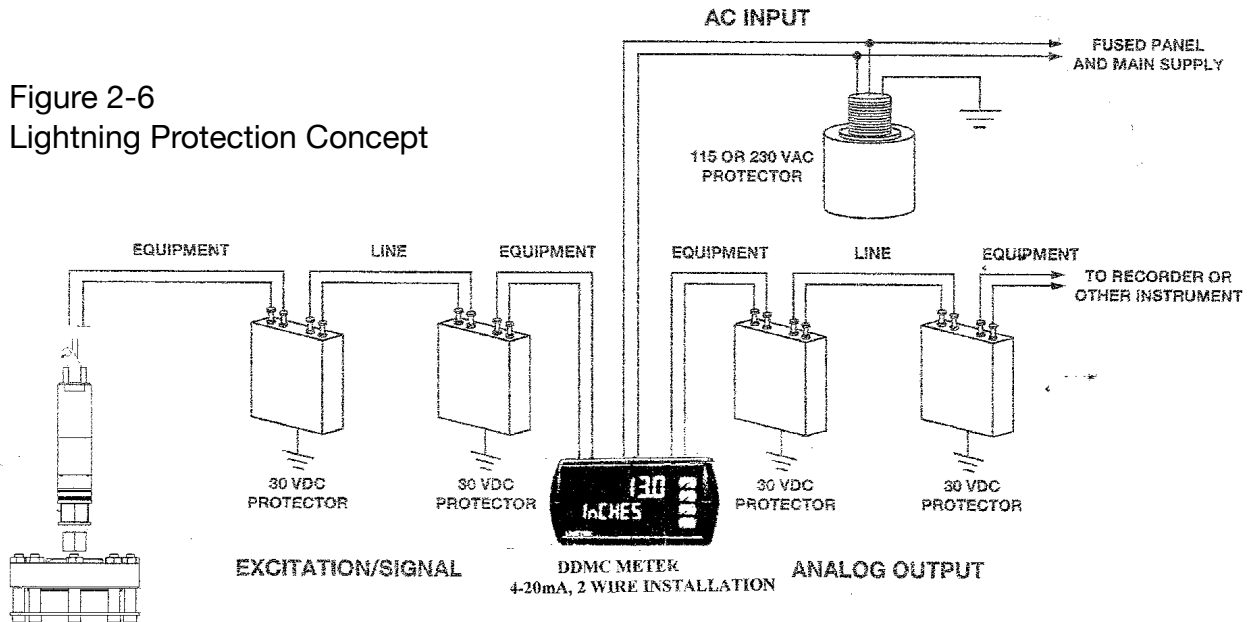

Figure 2-5
Wiring with No Lightning Protection Options

2.5.3 Lightning Protection Installation Concept

1. Lightning protection devices should be placed as close to the instrument as possible.
2. If the distance between the meter and transmitter, or the meter and recorder is less than 100 ft., only 1 protector per line may be used.
3. This or any installation cannot protect against a direct lightning strike, or secondary strikes of sufficient magnitude. AMETEK PMT Products cannot accept responsibility for damage due to lightning or secondary surges.
4. Proper installation including grounding require detailed installation drawing. Consult factory.

Figure 2-6
Lightning Protection Concept



2.6 Cable Termination

Instructions to installing the Ametek Submersible Transmitter using the supplied desiccant canister:



Remove Power Source During Installation.

This Ametek submersible transmitter is equipped with a sealed termination area and moisture absorbing desiccant canister. The purpose is to restrict moisture from entering the transmitter from the cable termination. **It is important that the cable termination not be altered.** Both potting and

2.6 Cable Termination (Continued)

solder blockers are used to restrict the moisture path. If a shorter length of cable is required, it is highly recommended that the cable be coiled instead of being cut.

The assembly is shipped complete to prevent moisture from entering during shipment and storage and to show the user how it will ultimately be connected.

To install the cable termination, it is recommended that a NEMA box be employed. The submersible cable enters the box through an included strain relief (cable is a 0.24" diameter). The red wire is the V+ lead and the black is the V- lead in a 4/20 mA loop. The green wire is a safety ground and should be tied to earth ground. The shield wire connection to earth ground is optional depending on EMI conditions in the area. The shield wire is terminated to the case internally.

The tubing should be connected to the desiccant canister though the use of the included fittings. There is one fitting at the cable end and another at the canister inlet. The tubing is removable from the fittings for ease of connection and replacement of the canister. Remove the yellow plug from the canister outlet prior to use.

The canister has a blue color when installed. Entering moisture becomes trapped within the desiccant canister. If moisture is absorbed inside in sufficient amounts, the color changed to pink. At that point the canister should be replaced. Use Ametek part #K234436 for full original assembly with tubing. The fitting and tubing at the canister inlet can be removed using a small wrench and reused with the replacement cartridge only part #K234446.

Complete assembly
with tubing
part #K234436.

Replacement
cartridge only
part #K234446



Figure 2-7
Desiccant Canister

Section 3: Accessories

3.1 Parts & Accessories

LMA912

30Vdc Lightning and surge protector for excitation and signal lines to the milliamper transmitter or meter analog output lines to other instruments

LMA918

Lightning & surge protector for 115Vac input line to a controller /meter

LMA919

Lightning & surge protector for 230Vac input line to a controller/meter

K234436

Moisture Absorbing Desiccant Canister original kit with tubing

K234446

Replacement cartridge only (some assembly required)

3.2 Ordering Parts & Accessories

When ordering replacement parts, supply the following information:

1. Part description and part number.
2. Quantity of each item required.
3. Shipping instructions and address.

Contact:



AMETEK STC

PMT Products

205 Keith Valley Road

Horsham, PA 19044

U.S.A.

Tel: 215-674-1234

Email: mctpmt.sales@ametek.com

www.ametekusg.com

Section 4: Troubleshooting



WARNING:

If the Level Measurement System is located in a hazardous environment, do not open the enclosure cover or make/break any electrical connections without first disconnecting electrical power at the source. Ensure that the wiring, electrical fittings and conduit connections conform to the electrical codes for the specific location and hazard level.

4.1 Problem/Cause/Checks

Controller/meter Display Drifting:

May be water in cable causing short circuit; look for kink or damaged cable; check for broken wires, loose or corroded connections, or obvious short circuits;

With transmitter wires disconnected, resistance between red or black lead and shield should not exceed 15 megohms.



Controller/meter Display Incorrect:

May be wrong transmitter connections; check wiring.

May be defective transmitter; check as above, replace transmitter.

May also be controller/meter problems, such as calibration.

4.2 Factory Assistance



AMETEK STC

PMT Products

205 Keith Valley Road

Horsham, PA 19044

U.S.A.

Tel: 215-674-1234

Email: mctpmt.sales@ametek.com

4.2 Factory Assistance (Continued)

Please provide the following information:

- Instrument Model Number and serial number
- Description of problem being experienced
- Description and location of the installation

4.4 Equipment Return

In order to provide the best service, any equipment being returned for repair or credit must be pre-approved by the factory.

In many applications, sensing elements are exposed to hazardous materials.

- **OSHA mandates** that our employees be informed and protected from hazardous chemicals.
- **Material Safety Data Sheets (MSDS)** listing the hazardous materials to which the sensing element has been exposed **MUST** accompany any repair.

It is your responsibility to fully disclose all chemicals and **decontaminate** the sensing element.

To obtain a return authorization (RA#)

Contact: Tel: 215-674-1234

email: mctpmt.sales@ametech.com

- Please provide the following information:
- Model Number of Return Equipment
- Serial Number
- Original Purchase Order Number
- Process Materials to which the equipment has been exposed.
- MSDS sheets for any hazardous materials
- Billing Address
- Shipping Address
- Purchase Order Number for Repairs

Please include a purchase order even if the repair is under warranty. If repair is covered under warranty, you will not be charged.

Ship equipment freight prepaid to:

AMETEK STC
PMT Products
205 Keith Valley Road
Horsham, PA 19044
Tel: 215-674-1234

*mark the RA# clearly on the outside of the carton and all paperwork.

Section 5: Specifications

5.1 Model 675 Series Transmitter

Ranges:

- User customizable ranges between 0-6 psi (13.8 ft of water) and 0-60 psi (138 ft of water)

Output:

- 4 to 20 mA, 2 wire, current limited to 30 mA DC

Power Supply:

- 12 to 40 VDC with reverse polarity surge protection; Limited to 28 VDC for Intrinsic Safety with Approved Power Supply.

Loop Resistance:

1400 ohms maximum at 40 volts

Temperature Range: **

- Ambient Operating: -25° to 180°F (-32° to 82°C)
- Storage: -40° to 180°F (-40° to 82°C)
- ** If submerged in a liquid that has frozen, damage will result.

Overrange Effect:

- $\pm 0.15\%$ full scale at 200% of maximum range

Overrange Limit:

- 200% of maximum range

Burst Pressure:

- 3X Upper Range Limit

Accuracy:

- $\pm 0.25\%$ full scale, BFSL (including linearity, hysteresis and repeatability)

Zero Offset:

- $\pm 1.00\%$ full scale set at 77°F (25°C)

Span:

- $\pm 0.50\%$ full scale set at 77°F (25°C)

Temperature Effects:

- Compensated: 32° to 122°F (0°C to 50°C);
- Maximum: 2.5% URL output change for $\pm 25^\circ\text{C}$ temperature change within compensated range when calibrated at 25°C. Consult factory for lower or alternate pressure ranges.

Power Supply Effect:

- $\pm 0.005\%$ full scale per volt

Diaphragm Seal:

- 316L SS construction with 4.75" OD and 3.5" sensing area

Construction:

- Diaphragm: 316L stainless steel
- Housing Type: 316 stainless steel
- Nut/Washer Type: 316 stainless steel
- Cable Grommet: Viton standard. Please contact factory for other options.
- Housing O Ring: Viton standard. Please contact factory for other options.
- Cable Jacket: Polyurethane (Standard). See Model Code.

Media Compatibility:

- Reference materials of construction

Electrical Connection:

- Attached 20 gauge vented polyurethane shielded cable. Unspliced lengths available up to 5000 ft. (1662 m)

Weight:

- 7 lb. 3 oz (Without cable)

Approvals:

- Meets CSA requirements for intrinsically safe operation in hazardous locations as designated by Class I, Div 1, Groups A, B, C & D and Class II, Groups E, F & G. Temperature Code T3C (when connected per Ametek drawing K750535). 

Options and Accessories:

- DDMC Meter Controller and Housing
- Stainless steel support cable part #K515183 (factory installed with tie wraps).

***see drawing K750535 for cable length limits for intrinsically safe installation.

Section 6: Drawings

6.1 Intrinsic Safety

**BASIC INSTALLATION CIRCUIT DIAGRAM
(4-20mA OUTPUT ONLY)**

HAZARDOUS LOCATION
HAZARDOUS (CLASSIFIED) LOCATION, CLASS III, DIVISION 1, GROUPS A, B, C, D, E, F, G, H, I, J, K, L, M, N, O, P, Q, R, S, T, U, V, W, X, Y, Z
CLASS III, DIVISION 1, GROUPS A, B, C, D, E, F, G, H, I, J, K, L, M, N, O, P, Q, R, S, T, U, V, W, X, Y, Z

NON-HAZARDOUS LOCATION
NON-HAZARDOUS LOCATION

HAZARDOUS LOCATION
HAZARDOUS (CLASSIFIED) LOCATION, CLASS III, DIVISION 1, GROUPS A, B, C, D, E, F, G, H, I, J, K, L, M, N, O, P, Q, R, S, T, U, V, W, X, Y, Z
CLASS III, DIVISION 1, GROUPS A, B, C, D, E, F, G, H, I, J, K, L, M, N, O, P, Q, R, S, T, U, V, W, X, Y, Z

NON-HAZARDOUS LOCATION
NON-HAZARDOUS LOCATION

HAZARDOUS LOCATION
HAZARDOUS (CLASSIFIED) LOCATION, CLASS III, DIVISION 1, GROUPS A, B, C, D, E, F, G, H, I, J, K, L, M, N, O, P, Q, R, S, T, U, V, W, X, Y, Z
CLASS III, DIVISION 1, GROUPS A, B, C, D, E, F, G, H, I, J, K, L, M, N, O, P, Q, R, S, T, U, V, W, X, Y, Z

NON-HAZARDOUS LOCATION
NON-HAZARDOUS LOCATION

HAZARDOUS LOCATION
HAZARDOUS (CLASSIFIED) LOCATION, CLASS III, DIVISION 1, GROUPS A, B, C, D, E, F, G, H, I, J, K, L, M, N, O, P, Q, R, S, T, U, V, W, X, Y, Z
CLASS III, DIVISION 1, GROUPS A, B, C, D, E, F, G, H, I, J, K, L, M, N, O, P, Q, R, S, T, U, V, W, X, Y, Z

NON-HAZARDOUS LOCATION
NON-HAZARDOUS LOCATION

**REVISIONS TO THIS DOCUMENT REQUIRE AGENCY NOTIFICATION.
REFER TO DOCUMENT EN201-17.**

UNREVISIONED	DATE	BY	REVISION
1	1/21/04	BENNETT	REVISED
2	2/3/04	RR	REVISED
3	2/5/04	DILORETO	REVISED
4	2/5/04	REVISION A	REVISED
5	2/5/04	REVISION A	REVISED
6	2/5/04	REVISION A	REVISED
7	2/5/04	REVISION A	REVISED
8	2/5/04	REVISION A	REVISED
9	2/5/04	REVISION A	REVISED
10	2/5/04	REVISION A	REVISED
11	2/5/04	REVISION A	REVISED
12	2/5/04	REVISION A	REVISED
13	2/5/04	REVISION A	REVISED
14	2/5/04	REVISION A	REVISED
15	2/5/04	REVISION A	REVISED
16	2/5/04	REVISION A	REVISED
17	2/5/04	REVISION A	REVISED
18	2/5/04	REVISION A	REVISED
19	2/5/04	REVISION A	REVISED
20	2/5/04	REVISION A	REVISED
21	2/5/04	REVISION A	REVISED
22	2/5/04	REVISION A	REVISED
23	2/5/04	REVISION A	REVISED
24	2/5/04	REVISION A	REVISED
25	2/5/04	REVISION A	REVISED
26	2/5/04	REVISION A	REVISED
27	2/5/04	REVISION A	REVISED
28	2/5/04	REVISION A	REVISED
29	2/5/04	REVISION A	REVISED
30	2/5/04	REVISION A	REVISED
31	2/5/04	REVISION A	REVISED
32	2/5/04	REVISION A	REVISED
33	2/5/04	REVISION A	REVISED
34	2/5/04	REVISION A	REVISED
35	2/5/04	REVISION A	REVISED
36	2/5/04	REVISION A	REVISED
37	2/5/04	REVISION A	REVISED
38	2/5/04	REVISION A	REVISED
39	2/5/04	REVISION A	REVISED
40	2/5/04	REVISION A	REVISED
41	2/5/04	REVISION A	REVISED
42	2/5/04	REVISION A	REVISED
43	2/5/04	REVISION A	REVISED
44	2/5/04	REVISION A	REVISED
45	2/5/04	REVISION A	REVISED
46	2/5/04	REVISION A	REVISED
47	2/5/04	REVISION A	REVISED
48	2/5/04	REVISION A	REVISED
49	2/5/04	REVISION A	REVISED
50	2/5/04	REVISION A	REVISED
51	2/5/04	REVISION A	REVISED
52	2/5/04	REVISION A	REVISED
53	2/5/04	REVISION A	REVISED
54	2/5/04	REVISION A	REVISED
55	2/5/04	REVISION A	REVISED
56	2/5/04	REVISION A	REVISED
57	2/5/04	REVISION A	REVISED
58	2/5/04	REVISION A	REVISED
59	2/5/04	REVISION A	REVISED
60	2/5/04	REVISION A	REVISED
61	2/5/04	REVISION A	REVISED
62	2/5/04	REVISION A	REVISED
63	2/5/04	REVISION A	REVISED
64	2/5/04	REVISION A	REVISED
65	2/5/04	REVISION A	REVISED
66	2/5/04	REVISION A	REVISED
67	2/5/04	REVISION A	REVISED
68	2/5/04	REVISION A	REVISED
69	2/5/04	REVISION A	REVISED
70	2/5/04	REVISION A	REVISED
71	2/5/04	REVISION A	REVISED
72	2/5/04	REVISION A	REVISED
73	2/5/04	REVISION A	REVISED
74	2/5/04	REVISION A	REVISED
75	2/5/04	REVISION A	REVISED
76	2/5/04	REVISION A	REVISED
77	2/5/04	REVISION A	REVISED
78	2/5/04	REVISION A	REVISED
79	2/5/04	REVISION A	REVISED
80	2/5/04	REVISION A	REVISED
81	2/5/04	REVISION A	REVISED
82	2/5/04	REVISION A	REVISED
83	2/5/04	REVISION A	REVISED
84	2/5/04	REVISION A	REVISED
85	2/5/04	REVISION A	REVISED
86	2/5/04	REVISION A	REVISED
87	2/5/04	REVISION A	REVISED
88	2/5/04	REVISION A	REVISED
89	2/5/04	REVISION A	REVISED
90	2/5/04	REVISION A	REVISED
91	2/5/04	REVISION A	REVISED
92	2/5/04	REVISION A	REVISED
93	2/5/04	REVISION A	REVISED
94	2/5/04	REVISION A	REVISED
95	2/5/04	REVISION A	REVISED
96	2/5/04	REVISION A	REVISED
97	2/5/04	REVISION A	REVISED
98	2/5/04	REVISION A	REVISED
99	2/5/04	REVISION A	REVISED
100	2/5/04	REVISION A	REVISED

Model 675 Series Submersible Level Transmitter

EK INC.

6.2 Outline Drawings

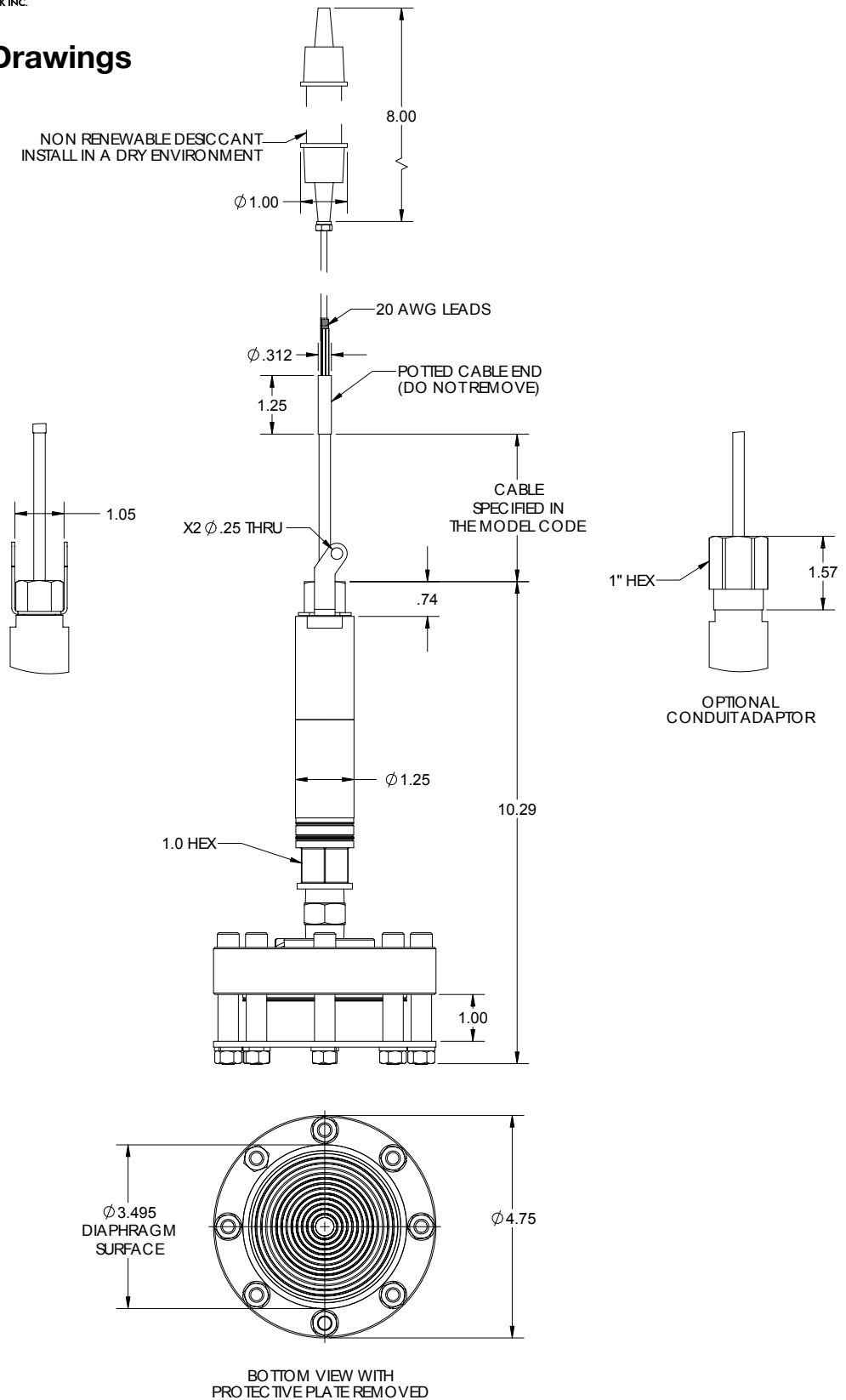



AMETEK STC
PMT Products
205 Keith Valley Road
Horsham, PA 19044

Tel: 215-674-1234
Email: mctpmt.sales@ametek.com
www.ametekusg.com