

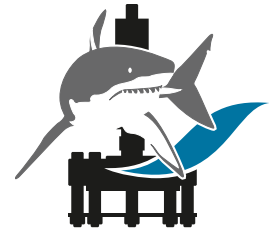

ELECTRONIC PRESSURE MEASUREMENT PRODUCTS

Model 675 Shark Cage Submersible Level Transmitter



DESCRIPTION

The Model 675 is specifically designed for slurry and highly viscous applications where clogging of the sensor area is common. The Model 675 uses a 3.5" flush diaphragm to prevent unwanted clogging of the sensing area. This submersible level device is made of 316L stainless steel which offers outstanding environmental protection and is available in depths up to 138 feet of water.

The non-fouling flush diaphragm and cage assembly are designed to eliminate unwanted buildup of debris, fats, oils, greases, and other bio-solids by eliminating any potential gaps on the measurement area. The high integrity seal's heavy construction eliminates the effects of turbulence on the sensor.

The 675 Series transmitters indicate the level of liquid by continuously measuring hydrostatic pressure via its sensing element, an ion implanted silicon semiconductor chip with integral Wheatstone Bridge circuit. Once the sensor measures the pressure, the data is transmitted by a 4 to 20 mA output signal. This design provides for excellent reliability in remote and inaccessible locations.

The Model 675 is approved for intrinsically safe operation in hazardous locations as designated by Class I, Div 1, Groups A, B, C & D and Class II, Groups E, F & G, when used with an approved barrier.

All standard Model 675 transmitters are fully potted internally. In addition, the 675 is supplied with a sealed cable termination area and moisture absorbing in-line desiccant to restrict moisture from entering the transmitter through the cable vent.

APPLICATIONS

- Lift stations
- Sewage and sludge levels
- Slurries
- Storm runoffs
- Wet wells
- Pump control

FEATURES

- Oversized 3.5" flush diaphragm to prevent clogging
- Designed for continuous submersion in the toughest applications
- 0.25% full scale accuracy
- Intrinsically safe for Class 1 Division 1
- Custom pressure ranges and cable lengths
- Heavy duty 316L stainless steel cage construction
- Two-wire, 4-20 mA standard output
- Reverse polarity and surge protection
- Weighs over 7 pounds (3.1 kilos)



Model 675 Shark Cage
with 3.5" flush diaphragm



ELECTRONIC PRESSURE MEASUREMENT PRODUCTS

Model 675 Shark Cage Submersible Level Transmitter

SPECIFICATIONS

Ranges:

Factory customizable ranges between 0-6 psi (13.8 ft of water) and 0-60 psi (138 ft of water)

Output: 4 to 20 mA, 2 wire, current limited to 30 mA DC

Power Supply:

12 to 40 VDC with reverse polarity surge protection; limited to 28 VDC for intrinsic safety with approved power supply

Loop Resistance: 1400 ohms maximum at 40 volts

Temperature Range:

General Ambient Operating: -25 to 180°F (-32 to 82°C)**

** CSA intrinsically safe when connected per AMETEK drawing BK750535. Temperature code T3C ambient high temperature limit (Tamb) = 104°F (40°C) max.

If submerged in a liquid that has frozen, damage will result

Storage: -40° to 180°F (-40°C to 82°C)

Overrange Effect: ±0.15% full scale at 200% of maximum range

Overrange Limit: 200% of maximum range

Burst Pressure: 3X upper range limit

Accuracy: ±0.25% full scale, BFSL (including linearity, hysteresis and repeatability)

Zero Offset: ±1.00% full scale set at 77°F (25°C)

Span: ±0.50% full scale set at 77°F (25°C)

Temperature Effects:

Compensated: 32° to 122°F (0°C to 50°C);

Maximum: ±2.5% URL output change for ±25°C temperature change within compensated range when calibrated at 25°C.

Consult factory for lower or alternate pressure ranges.

Power Supply Effect: ±0.005% full scale per volt

Diaphragm Seal: 316L SS construction with 4.75" OD and 3.5" sensing area

Construction:

Diaphragm: 316L stainless steel

Housing Type: 316 stainless steel

Nut/Washer Type: 316 stainless steel

Cable Grommet*: Viton (standard)

Housing O Ring*: Viton (standard)

Cable Jacket*: Polyurethane (standard)

Weight: 7 pounds (3.1 kilos)

** Please contact factory for other options.*

Media Compatibility: Reference materials of construction

Electrical Connection:

Attached 22 gauge, vented, polyurethane, shielded, cable; unspliced lengths available up to 5000 ft. (1662 m)

Weight: 7 lb. 3 oz (without cable)

Approvals:

Meets CSA requirements for intrinsically safe operation in hazardous locations as designated by Class I, Div 1, Groups A, B, C & D and Class II, Groups E, F & G. Temperature Code T3C (when used with approved barrier)



Options and Accessories:

- DDMC meter controller and housing
- Stainless steel support cable (K515183)
- LMA912 – DC lightning and surge protector
- LMA918 – 120 VAC lightning and surge protector
- Desiccant (K234436) – Complete original equipment with tubing and hardware
- Desiccant replacement cartridge only (K234446) – Requires some assembly

Other options available – consult factory.

Lightning and Surge Protectors

Part # LMA912 and LMA918



Desiccant

Part # K234436



ELECTRONIC PRESSURE MEASUREMENT PRODUCTS

Model 675 Shark Cage Submersible Level Transmitter

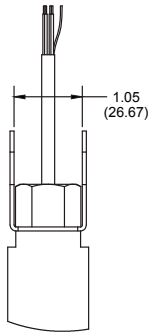

Optional 316 SS support cable is available. Factory assembled to the cable support bracket with tie wraps to the submersible cable (Part #K515183). Reduces strain on the electrical connection when raising or lowering the transmitter.

INCHES
(MM)

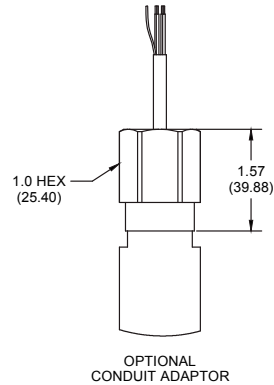
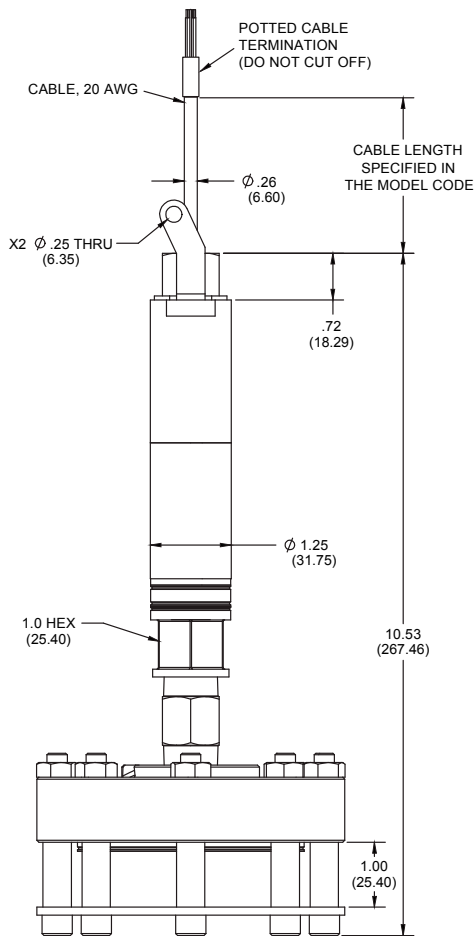

Model 575PB

An alternative model 575PB with smaller diameter diaphragm and cage assembly for lift station/slurry applications is available. Refer to the 575 series data sheet for details and specifications.

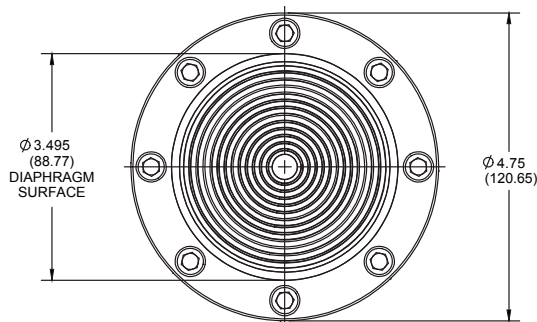

Bottom View With Protective Plate Removed





ELECTRONIC PRESSURE MEASUREMENT PRODUCTS

Model 675 Shark Cage Submersible Level Transmitter

Model Numbering:			
● 675 level transmitter			
675	Model 675 submersible level transmitter		
● Sensing port			
P	Shark cage 3.5" diameter diaphragm		
● Input / Output (approved power supply required)			
B	12 to 28 VDC/4 to 20 mA (standard)		
● Pressure ranges*		● Reference equivalents	
PSI	BAR		
0006	0.4B	0-13.8 ft. water	0-4.2 meters water
0015	001B	0-34.6 ft. water	0-10.5 meters water
0030	002B	0-69.2 ft. water	0-21.1 meters water
0060	004B	0-138 ft. water	0-42.2 meters water
● Electrical connection**			
M	22 AWG polyurethane vented cable with support bracket (K515072 cable)		
P	22 AWG polyurethane vented cable with conduit adaptor (K515072 cable)		
W	22 AWG polyurethane vented cable with cable support bracket and EMI protection		
● Diaphragm material			
L	316L stainless steel (standard)		
● Fill fluid			
S	Silicone oil (standard)		
M	Mineral oil		
● Cable length			
XXX	(specify length in feet)		
675	P	B	0006
M	L	S	100 feet

* Consult factory for other ranges
 ** Consult factory for other options

Moisture Absorbing Desiccant Canister

This AMETEK submersible transmitter utilizes a vented cable which allows the sensor to compensate for changes in atmospheric pressure. This vent tube can also provide a harmful path for moisture into the electronics, accelerating corrosion and sensor failure. AMETEK rectifies this issue by equipping each transmitter with a sealed termination area and moisture absorbing desiccant canister. The canister elements will change from a blue color to pink when it is time to be replaced.

The purpose is to restrict moisture from entering the transmitter from the cable vent tube. Spare desiccants are available for ordering. Reference AMETEK model number #K234436.

IN-LINE DISPOSABLE
 Initial assembly provided N/C with the Model 675 with vent tube cable





OPTIONS AND ACCESSORIES

Display Meters, Surge Protectors, Junction Boxes and Desiccants

DISPLAY METERS AND SYSTEMS

Model DDMC Digital Meter/Controller

Dual display meter provides power to the sensor with alarm and 4-20 mA analog output options. Standard panel mount housing or a NEMA 4X weathertight housing for field mounting is available. The weathertight housing also provides internal mounting locations for lightning and surge protectors.



LEVEL MATE™ III Level Measurement System

The complete LEVEL MATE III system includes a level sensor (various models are available), cable and a meter/controller all packaged in a NEMA 4X enclosure. Everything is factory programmed for easy installation and the LEVEL MATE III has an extended 2-year warranty.

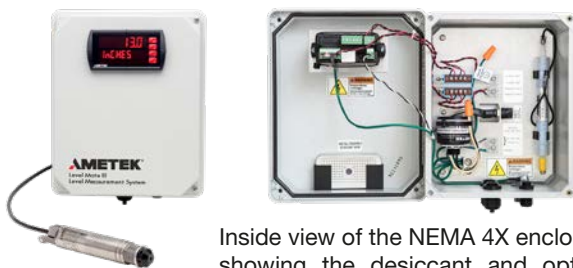

Inside view of the NEMA 4X enclosure showing the desiccant and optional surge protectors. Unit is factory wired so that the user needs to connect power and sensor only.

LIGHTNING AND SECONDARY SURGE PROTECTORS

Lightning protection units are available to help protect systems and components from lightning and secondary surges. These LP units are available in both 30 VDC (LMA912) for 24 VDC supply on excitation/signal lines and analog meter output lines to protect the meter and/or the transmitter as well as 115 VAC (LMA918) and 230 VAC (LMA919) to protect the meter on AC power input lines.



JUNCTION BOXES

Model SBJ100 with Reusable Desiccant

These boxes are used on long cable runs and provide quicker access to atmospheric reference. SBJ100 provides a clean, dry enclosure with an internal, reusable desiccant canister.



Back view of SBJ100 junction box that shows the reusable desiccant canister.

DESICCANTS

An initial desiccant is supplied with the SBJ100 and the LEVEL MATE III enclosure. The desiccant canister is reusable with visible color change when the time comes to replace the desiccant.

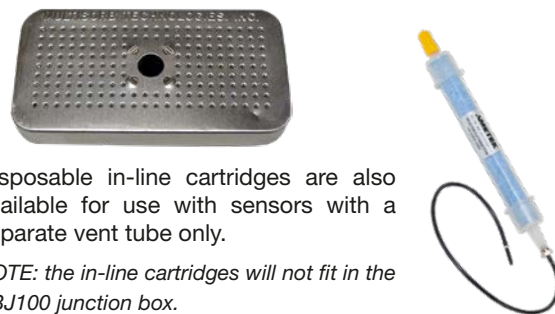

Disposable in-line cartridges are also available for use with sensors with a separate vent tube only.

NOTE: the in-line cartridges will not fit in the SBJ100 junction box.