

DDMC Analog Input Process Meter / Controller

Instruction Manual



- 1/8 DIN Digital Panel Meter with NEMA 4X, IP65 Front
- 0-20 mA, 4-20 mA, 0-5 V, 1-5 V, and ± 10 V Field Selectable Inputs
- Dual-Line 6-Digit Display, 0.6" (15 mm) & 0.46" (12 mm)
- Isolated 24 VDC @ 200 mA Transmitter Power Supply
- 2 or 4 Relays with Interlocking Capability + Isolated 4-20 mA Output Options
- Free PC-Based, On-Board, DDMC Meter View USB Programming Software
- No Assembly Required
- Sunlight Readable Display Models
- Operating Temperature Range: -40 to 65°C (-40 to 149°F)
- UL & C-UL Listed. E160849; 508 Industrial Control Equipment
- Input Power Options: 85-265 VAC / 90-265 VDC or 12-24 VDC / 12-24 VAC
- Display Input in Two Different Scales - Great for Level Applications
- Multi-Pump Alternation Control
- Round Horizontal Tank Function; Just Enter Diameter & Length
- 32-Point Linearization, Square Root Extraction and Programmable Exponent Function
- Programmable Display, Function Keys & Digital Input
- Relay Output Expansion Module
- RS-232 & RS-485 Serial Communication Options with Modbus RTU
- Password Protection
- 3-Year Warranty

AMETEK

205 Keith Valley Rd • Horsham, PA 19044 USA
Sales/Technical Support Telephone: +1 215-674-1234 • Fax: 215-323-9450
Email: mctpmt.sales@ametek.com • www.ametekusg.com



Disclaimer

The information contained in this document is subject to change without notice. AMETEK makes no representations or warranties with respect to the contents hereof and specifically disclaims any implied warranties of merchantability or fitness for a particular purpose. See Warranty Information and Terms & Conditions on www.ametekusg.com for complete details.

CAUTION

- Read complete instructions prior to installation and operation of the meter.

WARNINGS

- Risk of electric shock or personal injury.
- This product is not recommended for life support applications or applications where malfunctioning could result in personal injury or property loss. Anyone using this product for such applications does so at his/her own risk. AMETEK shall not be held liable for damages resulting from such improper use.

WARNING

Cancer and Reproductive Harm - www.P65Warnings.ca.gov

Limited Warranty

AMETEK warrants this product against defects in material or workmanship for the specified period under "Specifications" from the date of shipment from the factory. AMETEK's liability under this limited warranty shall not exceed the purchase value, repair, or replacement of the defective unit. See Warranty Information and Terms & Conditions on www.ametekusg.com for complete details.

Registered Trademarks

All trademarks mentioned in this document are the property of their respective owners.

© 2020 AMETEK. All rights reserved.

FREE DDMC Meter View Programming Software

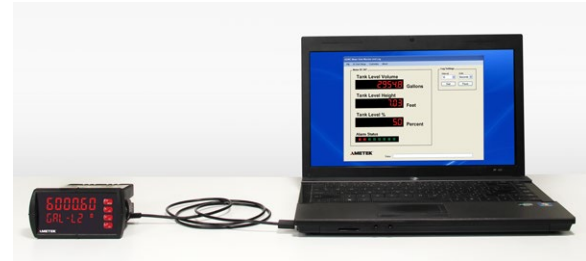

*The meter can be powered from the Micro USB connection. When using the Micro USB connection, **DO NOT** apply AC or DC power to the meter.*

The easiest and quickest way to program your meter is to use the FREE DDMC Meter View programming software. This software is loaded into the meter and connects and installs directly to your PC with a USB cable. We recommend that the first thing you do after taking the meter out of the box is connect the meter to your PC with the provided USB cable – do not use a different cable. **DO NOT** apply AC or DC power to the meter while your PC is connected to the meter as it will disrupt the USB connection. You do not even have to apply an input signal.

DDMC Meter View programming software is intuitive, and most customers can get their meter programmed as they like without even looking in the manual.

In addition to programming, the software may be used for:

- Monitoring
- Datalogging using your PC
- Generating and saving programming files for later use

Once your meter is programmed the way you want it, you can wire it up for your application per the instructions in this manual and install it. If you find that you need to make adjustments to the programming after the meter is installed, you can use the front panel buttons and the instructions in this manual to do so.

Table of Contents

Introduction.....	6
Ordering Information.....	7
Specifications	8
General.....	8
Process Input	9
Relays.....	9
Isolated 4-20 mA Transmitter Output	10
USB Connection.....	10
On-Board Digital Input (F4)	10
Modbus® RTU Serial Communications.....	10
DDMC Meter View Software.....	10
Compliance Information.....	11
Safety	11
Electromagnetic Compatibility.....	11
Safety Information	11
Installation.....	11
Unpacking.....	11
Panel Mounting Instructions	12
Mounting Dimensions	12
Enclosure Dimensions	13
Installation Overview	14
DDMC Meter View Software.....	14
DDMC Meter View Installation	14
Transmitter Supply Voltage Selection (P+, P-)	15
Connections	15
Connectors Labeling	15
Power Connections.....	16
Signal Connections	16
Modbus RTU Serial Communications	16
Relay Connections.....	16
Switching Inductive Loads.....	17
F4 Digital Input Connections.....	17
4-20 mA Output Connections.....	17
Analog Output Power Supply.....	17
External Relays Connections.....	18
Interlock Relay Feature	18
Setup and Programming.....	19
Overview	19
Front Panel Buttons and Status LED Indicators.....	19
Display Functions & Messages.....	20
Main Menu.....	21
Setting Numeric Values	22
Setting Up the Meter (SEtUP)	22
Setting the Input Signal (InPUt).....	22
Setting the Display Units or Custom Tags (unItS)	23
Setting the Decimal Point (dEc Pt)	23
Programming the Meter (PrOG)	24
Setting the Display Parameter & Intensity (dSPLRy)	26
Display Intensity (d-IntY).....	26
Setting the Relay Operation (rELRY)	27
Setting the Relay Action.....	27
Programming Set and Reset Points.....	28
Setting Fail-Safe Operation.....	28
Programming Time Delay	28
Relay Action for Loss of 4-20 mA Input (Loop Break).....	28
Relay and Alarm Operation Diagrams	28
High Alarm Operation (Set > Reset)	28
Low Alarm Operation (Set < Reset)	29
High Alarm with Fail-Safe Operation (Set > Reset).....	29
Low Alarm with Fail-Safe Operation (Set < Reset).....	29

Time Delay Operation	29
Pump Alternation Control Operation	30
Relay Sampling Operation	30
Relay Operation Details	31
Overview	31
Relays Auto Initialization	31
Fail-Safe Operation	31
Front Panel LEDs	31
Latching and Non-Latching Relay Operation	31
Non-Latching Relay (R _u L _o)	32
Non-Latching Relay with Manual Reset (R _n rR _n)	32
Latching Relay (L _R cH)	32
Latching Relay with Clear (L _c -CLR)	32
Acknowledging Relays	33
Pump Alternation Control Applications (RL _{TE} r _n)	33
Setting Up the Interlock Relay (Force On) Feature	34
Scaling the 4-20 mA Analog Output (R_ou_t)	35
Reset Menu (rESEt)	35
Manual Control Menu (C_ontrL)	35
Setting Up the Password (PR55)	36
Protecting or Locking the Meter	36
Making Changes to a Password Protected Meter	36
Disabling Password Protection	36
Advanced Features Menu	37
Advanced Features Menu & Display Messages	37
Noise Filter (F _i LtEr)	38
Noise Filter Bypass (bYP55)	38
Rounding Feature (r _o u _n d)	38
Modbus RTU Serial Communications (SEr _i AL)	38
Select Menu (SELEct)	39
Input Signal Conditioning (F _u nc _t ion)	39
Low-Flow Cutoff (L _o wFF)	40
Analog Output Programming (R _o u _t P _r)	40
Programmable Function Keys User Menu (u5Er)	41
Tare (tRrE)	41
Internal Source Calibration (iCAL)	42
Meter Operation	43
Front Panel Buttons Operation	43
Function Keys Operation	43
F4 Operation	43
Maximum/Minimum Readings	43
Troubleshooting	44
Diagnostics Menu (d_iAG)	44
Determining Software Version	44
Reset Meter to Factory Defaults	44
Factory Defaults & User Settings	45
Troubleshooting Tips	46
EU Declaration of Conformity	47

Table of Figures

Figure 1. 1/8 DIN Panel Cutout Dimensions	12
Figure 2. Panel Mounting Details	12
Figure 3. Meter Dimensions - Side View	12
Figure 4. Meter Dimensions - Top View	12
Figure 5. Transmitter Supply Voltage Selection	15
Figure 6. PD6000-##0-DB Connectors Label	15
Figure 7. PD6000-##2-DB Connectors Label	15
Figure 8. PD6000-##3-DB Connectors Label	15
Figure 9. PD6000-##4-DB Connectors Label	15
Figure 10. PD6000-##5-DB Connectors Label	15
Figure 11. PD6000-##7-DB Connectors Label	15
Figure 12. Power Connections	16
Figure 13. Transmitters Powered by Internal Supply	16
Figure 14. Transmitter Powered by External Supply or Self-Powered.....	16
Figure 15. Voltage Input Connections	16
Figure 16. Relay Connections	16
Figure 17. AC and DC Loads Protection.....	17
Figure 18. Low Voltage DC Loads Protection	17
Figure 19. F4 Digital Input Connections	17
Figure 20. 4-20 mA Output Connections	17
Figure 21. Analog Output Supply Powering Other Devices.....	17
Figure 22. Expansion Module & DIN Rail Mounting Kit.....	18
Figure 23. External Relays Module Connections.....	18
Figure 24. Interlock Connections	18

Introduction

Front, back and in between, the DDMC meter boasts specifications, features and functionality that make it the only 1/8 DIN process meter you will ever need. The number one feature that makes the DDMC such a useful device is its built-in 24 VDC @ 200 mA power supply to drive the transmitter. This feature not only saves the cost of an external power supply, but also greatly simplifies wiring. In addition, there is a second 24 VDC @ 40 mA power supply provided with the 4-20 mA output option.

Another reason why the DDMC Meter is the only process meter you will ever need is its NEMA 4X rated front panel. This means you can install the DDMC in panels exposed to moisture, dust and other adverse conditions. The next thing to notice is the 6-digit dual-line display that can display numbers up to 999,999 on the upper line and show either a tag or the input in a different scale on the lower line.

Other key features include four relays and 4-20 mA output option, advanced input signal conditioning like automatic round horizontal tank linearization, function keys, pump alternation capability, and Modbus RTU serial communications. Finally, all these features and capabilities can easily be programmed with free DDMC Meter View PC-based software.

Ordering Information

Standard Models

85-265 VAC Models		
Model	Reorder #	Options Installed
PD6200-6R0-DB	401-0910-002-00	No options
PD6200-6R2-DB	401-0912-002-00	2 relays
PD6200-6R3-DB	401-0910-002-A0	4-20 mA output
PD6200-6R4-DB	401-0914-002-00	4 relays
PD6200-6R5-DB	401-0912-002-A0	2 relays & 4-20 mA output
PD6200-6R7-DB	401-0914-002-A0	4 relays & 4-20 mA output

12-24 VDC Models		
Model	Reorder #	Options Installed
PD6200-7R0-DB	401-0920-002-00	No options
PD6200-7R2-DB	401-0922-002-00	2 relays
PD6200-7R3-DB	401-0920-002-A0	4-20 mA output
PD6200-7R4-DB	401-0924-002-00	4 relays
PD6200-7R5-DB	401-0922-002-A0	2 relays & 4-20 mA output
PD6200-7R7-DB	401-0924-002-A0	4 relays & 4-20 mA output

Accessories

Model	Reorder #	Description
PDA2811-DB	261-0011-162	Deep Plastic Enclosure for 1 Meter
PDA1004-DB	K740366	4 SPST (Form A) relays expansion module
PDA8008		USB Adapter
LMA918		Lightning and secondary surge protector used in the 115 VAC input power to protect the meter
LMA919		Lightning and secondary surge protector used in the 230 VAC input power to protect the meter
LMA912		Lightning and secondary surge protector used in the transmitter excitation/signal lines and meter analog input lines to protect the meter and/or the transmitter

Meter and Enclosure

85-265 VAC Models		
Model	Reorder #	Options Installed
PDS6200-6R0-DB	401-0910-007-00	No options
PDS6200-6R2-DB	401-0912-007-00	2 relays
PDS6200-6R3-DB	401-0910-007-A0	4-20 mA output
PDS6200-6R4-DB	401-0914-007-00	4 relays
PDS6200-6R5-DB	401-0912-007-A0	2 relays & 4-20 mA output
PDS6200-6R7-DB	401-0914-007-A0	4 relays & 4-20 mA output

12-24 VDC Models		
Model	Reorder #	Options Installed
PDS6200-7R0-DB	401-0920-007-00	No options
PDS6200-7R2-DB	401-0922-007-00	2 relays
PDS6200-7R3-DB	401-0920-007-A0	4-20 mA output
PDS6200-7R4-DB	401-0924-007-00	4 relays
PDS6200-7R5-DB	401-0922-007-A0	2 relays & 4-20 mA output
PDS6200-7R7-DB	401-0924-007-A0	4 relays & 4-20 mA output

Manufactured by Precision Digital Corporation,
233 South St, Hopkinton MA 01748 USA

Specifications

Except where noted all specifications apply to operation at +25°C.

General

Display	Line 1: 0.60" (15 mm) high, red LEDs Line 2: 0.46" (12 mm) high, red LEDs 6 digits each (-99999 to 999999), with lead zero blanking
Display Intensity	Eight user selectable intensity levels. Default value is six.
Display Update Rate	5/second (200 ms)
Overrange	Display flashes 999999
Underrange	Display flashes -999999
Display Assignment	Display lines 1 and 2 may be assigned to PV1, PV2, PCT, d r-u, d gross, d nt-g, max/min, max & min, set points, units (display line 2 only), or Modbus input.
Programming Methods	Four front panel buttons, digital inputs, PC and DDMC Meter View programming software, or Modbus registers.
Noise Filter	Programmable from 2 to 199 (0 will disable filter)
Filter Bypass	Programmable from 0.1 to 99.9% of calibrated span
Recalibration	All ranges are calibrated at the factory. Recalibration is recommended at least every 12 months.
Max/Min Display	Max/min readings reached by the process are stored until reset by the user or until power to the meter is turned off.
Rounding	Select 1, 2, 5, 10, 20, 50, or 100 (e.g. rounding = 10, value = 123.45, display = 123.50).
Tare	Tare function zeros out the meter to accommodate for weight of a container. Tare function can be assigned to a function key, F4 terminal, or a digital input.
Password	Three programmable passwords restrict modification of programmed settings. Pass 1: Allows use of function keys and digital inputs Pass 2: Allows use of function keys, digital inputs and editing set/reset points Pass 3: Restricts all programming, function keys, and digital inputs.
Non-Volatile Memory	All programmed settings are stored in non-volatile memory for a minimum of ten years if power is lost.
Power Options	85-265 VAC 50/60 Hz; 90-265 VDC, 20 W max; 12-24 VDC, 12-24 VAC, 15 W max. Powered over USB for configuration only.
Fuse	Required external fuse: UL Recognized, 5 A max, slow blow; up to 6 meters may share one 5 A fuse
Normal Mode Rejection	Greater than 60 dB at 50/60 Hz
Isolation	4 kV input/output-to-power line 500 V input-to-output or output-to-P+ supply

Overvoltage Category	Installation Overvoltage Category II: Local level with smaller transient overvoltages than Installation Overvoltage Category III.
Environmental	Operating temperature range: -40 to 65°C (-40 to 149°F) Storage temperature range: -40 to 85°C (-40 to 185°F) Relative humidity: 0 to 90% non-condensing
Connections	Removable screw terminal blocks accept 12 to 22 AWG wire, RJ45 for external relays, digital I/O, and serial communication adapters.
Enclosure	1/8 DIN, high impact plastic, UL 94V-0, color: black
Front Panel	NEMA 4X, IP65
Mounting	1/8 DIN panel cutout required: 3.622" x 1.772" (92 mm x 45 mm) Two panel mounting bracket assemblies are provided.
Tightening Torque	Screw terminal connectors: 5 lb-in (0.56 Nm)
Overall Dimensions	4.68" x 2.45" x 5.64" (119 mm x 62 mm x 143 mm) (W x H x D)
Weight	9.5 oz (269 g)
Warranty	3 years parts & labor.

Process Input

Inputs	Field selectable: 0-20 mA, 4-20 mA ±10 V (0-5 V, 1-5 V, 0-10 V) Modbus PV (Slave)	
Isolated Transmitter Power Supply	Terminals P+ & P-: 24 VDC ±10%. All models selectable for 24, 10, or 5 VDC supply (internal jumper J4). 85-265 VAC models rated @ 200 mA max, 12-24 VDC powered models rated @ 100 mA max. 5 & 10 VDC supply rated @ 50 mA max. Refer to <i>Transmitter Supply Voltage Selection (P+, P-)</i> on page 15.	
Accuracy	±0.03% of calibrated span ±1 count, square root & programmable exponent accuracy range: 10-100% of calibrated span	
Temperature Drift	0.005% of calibrated span/°C max from 0 to 65°C ambient, 0.01% of calibrated span/°C max from -40 to 0°C ambient	
Input Signal Conditioning	Linear, square root, programmable exponent, or round horizontal tank volume calculation	
Multi-Point Linearization	2 to 32 points for PV or PV1 2 to 8 points for PV2 (Dual-scale Level feature)	
Programmable Exponent	User selectable from 1.0001 to 2.9999 for open channel flow	
Round Horizontal Tank	Diameter & Length: 999.999 inch or cm calculates volume in gallons or liters respectively.	
Low-Flow Cutoff	0.0 to 999,999.9 (0 disables cutoff function). Point below at which display always shows zero.	
Decimal Point	Up to five decimal places or none: dddddd, ddddd, dddd, ddd, dd, or ddddd	
Calibration Range	Input Range	Minimum Span Input 1 & 2
	4-20 mA	0.15 mA
	±10 V	0.10 V
	An error message will appear if the input 1 and input 2 signals are too close together.	
Input Impedance	Voltage ranges: greater than 500 kΩ Current ranges: 50 - 100 Ω (depending on resettable fuse impedance)	
Input Overload	Current input protected by resettable fuse, 30 VDC max. Fuse resets automatically after fault is removed.	
HART Transparency	The meter does not interfere with existing HART communications; it displays the 4-20 mA primary variable and it allows the HART communications to pass through without interruption. The meter is not affected if a HART communicator is connected to the loop. The meter does not display secondary HART variables.	

Relays

Rating	2 or 4 SPDT (Form C) internal and/or 4 SPST (Form A) external; rated 3 A @ 30 VDC and 125/250 VAC resistive load; 1/14 HP (≈ 50 W) @ 125/250 VAC for inductive loads
Noise Suppression	Noise suppression is recommended for each relay contact switching inductive loads. See <i>Switching Inductive Loads</i> on page 17 for details.
Deadband	0-100% of span, user programmable
High or Low Alarm	User may program any alarm for high or low trip point. Unused alarm LEDs and relays may be disabled (turn off).
Relay Operation	<ul style="list-style-type: none"> • Automatic (non-latching) and/or manual reset • Latching (requires manual acknowledge) with or without clear • Pump alternation control (2-8 relays) • Sampling (based on set point and time) • Off (disable unused relays and enable Interlock feature) • Manual on/off control mode
Relay Reset	User selectable via front panel button, F4 terminal at back of meter, external contact closure on digital inputs, or through serial communications.
Time Delay	0 to 999.9 seconds, on & off relay time delays. Programmable and independent for each relay
Fail-Safe Operation	Programmable and independent for each relay. <i>Note: Relay coil is energized in non-alarm condition. In case of power failure, relay will go to alarm state.</i>
Auto Initialization	When power is applied to the meter, relays will reflect the state of the input to the meter.
Additional Relays	An external module, model PDA1004-DB, is available to add 4 SPST 3 A relays to the meter.

Isolated 4-20 mA Transmitter Output

Output Source	Process variable (PV), max, min, set points 1-8, Modbus input, or manual control mode		
Scaling Range	1.000 to 23.000 mA for any display range		
Calibration	Factory calibrated: 4.000 to 20.000 = 4-20 mA output		
Analog Out Programming	23.000 mA maximum for all parameters: Ovrange, underrange, max, min, and break		
Accuracy	$\pm 0.1\%$ of span ± 0.004 mA		
Temperature Drift	0.4 $\mu\text{A}/^\circ\text{C}$ max from 0 to 65 $^\circ\text{C}$ ambient, 0.8 $\mu\text{A}/^\circ\text{C}$ max from -40 to 0 $^\circ\text{C}$ ambient <i>Note: Analog output drift is separate from input drift.</i>		
Isolated Transmitter Power Supply	Terminals I+ & R: 24 VDC $\pm 10\%$. May be used to power the 4-20 mA output or other devices. All models rated @ 40 mA max.		
External Loop Power Supply	35 VDC maximum		
Output Loop Resistance	Power supply	Minimum	Maximum
	24 VDC	10 Ω	700 Ω
	35 VDC (external)	100 Ω	1200 Ω

USB Connection

Function	Programming only
Compatibility	USB 2.0 Standard, Compliant
Connector Type	Micro-B receptacle
Cable	USB A Male to Micro-B Cable
Driver	Microsoft® Windows® XP/Vista/7/8/10
Power	USB port provides power to the meter. DO NOT apply AC or DC power to the meter while the USB port is in use.

On-Board Digital Input (F4)

Function	Remote operation of front-panel buttons, acknowledge/reset relays, reset max/min values. See <i>Function Keys & Digital I/O Available Settings</i> on page 41 for a complete list of capabilities.
Contacts	3.3 VDC on contact. Connect normally open contacts across F4 to COM
Logic Levels	Logic High: 3 to 5 VDC Logic Low: 0 to 1.25 VDC
Additional I/O	Up to 2 external modules with 4 digital inputs and 4 digital outputs each can be added.

Modbus® RTU Serial Communications

Slave Id	1 – 247 (Meter address)
Baud Rate	300 – 19,200 bps
Transmit Time Delay	Programmable between 0 and 199 ms
Data	8 bit (1 start bit, 1 or 2 stop bits)
Parity	Even, Odd, or None with 1 or 2 stop bits
Byte-To-Byte Timeout	0.01 – 2.54 second
Turn Around Delay	Less than 2 ms (fixed)

Note: Refer to the Modbus Register Tables located at www.ametekusg.com for details.

DDMC Meter View Software

Availability	Download directly from meter
System Requirements	Microsoft® Windows® XP/Vista/7/8/10
Communications	USB 2.0 (for programming only) (Standard USB A to Micro USB B) RS-232 adapter, RS-485 adapter and RS-485 to USB converter (programming, monitoring, and data logging)
Configuration	Configure meters one at a time
Power	USB port provides power to the meter. DO NOT apply AC or DC power to the meter while the USB port is in use.

Compliance Information

Safety

UL & C-UL Listed	USA & Canada UL 508 Industrial Control Equipment
UL File Number	E160849
Front Panel	UL Type 4X, NEMA 4X, IP65; panel gasket provided
Low Voltage Directive	EN 61010-1:2010 Safety requirements for measurement, control, and laboratory use

Electromagnetic Compatibility

Emissions	EN 55022:2010 Class A ITE emissions requirements
Radiated Emissions	Class A
AC Mains Conducted Emissions	Class A
Immunity	EN 61326-1:2013 Measurement, control, and laboratory equipment EN 61000-6-2:2005 EMC heavy industrial generic immunity standard
RFI - Amplitude Modulated	80 -1000 MHz 10 V/m 80% AM (1 kHz) 1.4 - 2.0 GHz 3 V/m 80% AM (1 kHz) 2.0 - 2.7 GHz 1 V/m 80% AM (1 kHz)
Electrical Fast Transients	±2kV AC mains, ±1kV other
Electrostatic Discharge	±4kV contact, ±8kV air
RFI - Conducted	10V, 0.15-80 MHz, 1kHz 80% AM
AC Surge	±2kV Common, ±1kV Differential
Surge	1KV (CM)
Power-Frequency Magnetic Field	30 A/m 70%V for 0.5 period
Voltage Dips	40%V for 5 & 50 periods 70%V for 25 periods
Voltage Interruptions	<5%V for 250 periods

Note:

Testing was conducted on meters installed through the covers of grounded metal enclosures with cable shields grounded at the point of entry representing installations designed to optimize EMC performance.

Safety Information

⚠ CAUTION

- Read complete instructions prior to installation and operation of the meter.

⚠ WARNINGS

- Risk of electric shock or personal injury.
- Hazardous voltages exist within enclosure. Installation and service should be performed only by trained service personnel.

Installation

There is no need to remove the meter from its case to complete the installation, wiring, and setup of the meter for most applications. Instructions are provided for changing the transmitter power supply to output 5 or 10 VDC instead of 24 VDC. See *Figure 5. Transmitter Supply Voltage Selection* on page 15.

Unpacking

Remove the meter from box. Inspect the packaging and contents for damage. Report damages, if any, to the carrier. If any part is missing or the meter malfunctions, please contact your supplier or the factory for assistance.

Panel Mounting Instructions

- Prepare a standard 1/8 DIN panel cutout - 3.622" x 1.772" (92 mm x 45 mm). Refer to *Figure 1. 1/8 DIN Panel Cutout Dimensions* below for more details.
- Clearance: allow at least 6.0" (152 mm) behind the panel for wiring.
- Panel thickness: 0.04" - 0.25" (1.0 mm - 6.4 mm). Recommended minimum panel thickness to maintain Type 4X rating: 0.06" (1.5 mm) steel panel, 0.16" (4.1 mm) plastic panel.
- Remove the two mounting brackets provided with the meter (back-off the two screws so that there is ¼" (6.4 mm) or less through the bracket. Slide the bracket toward the front of the case and remove).
- Insert meter into the panel cutout.
- Install mounting brackets and tighten the screws against the panel. To achieve a proper seal, tighten the mounting bracket screws evenly until meter is snug to the panel along its short side. **DO NOT OVER TIGHTEN**, as the rear of the panel may be damaged.

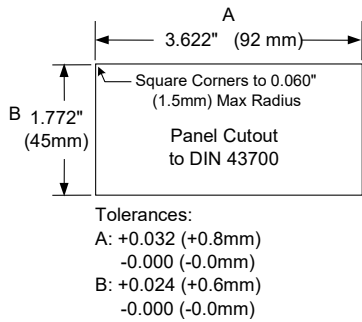
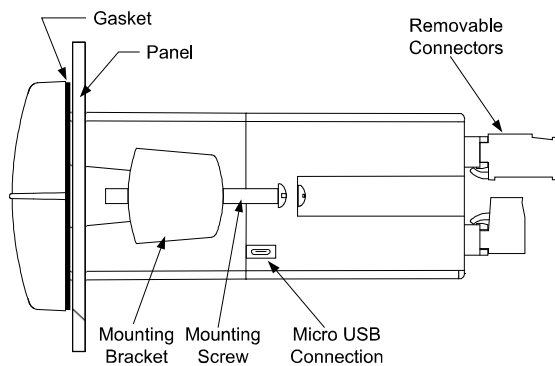

Figure 1. 1/8 DIN Panel Cutout Dimensions



DO NOT apply AC or DC power to the meter when using the Micro USB connection.

Figure 2. Panel Mounting Details

Mounting Dimensions

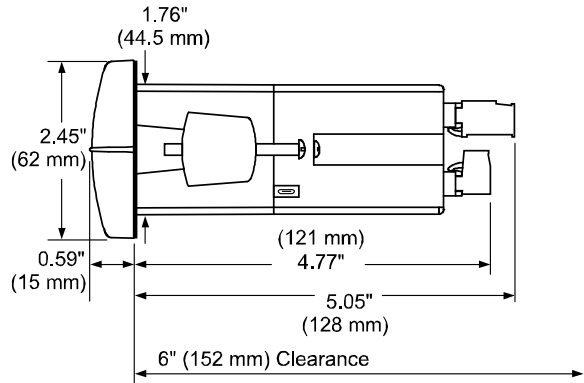

Figure 3. Meter Dimensions - Side View

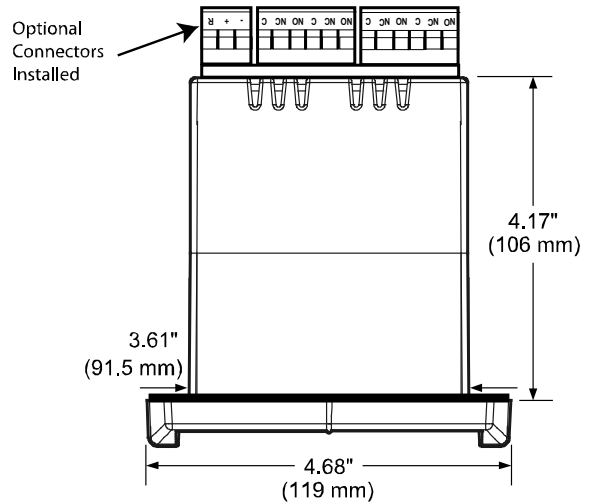
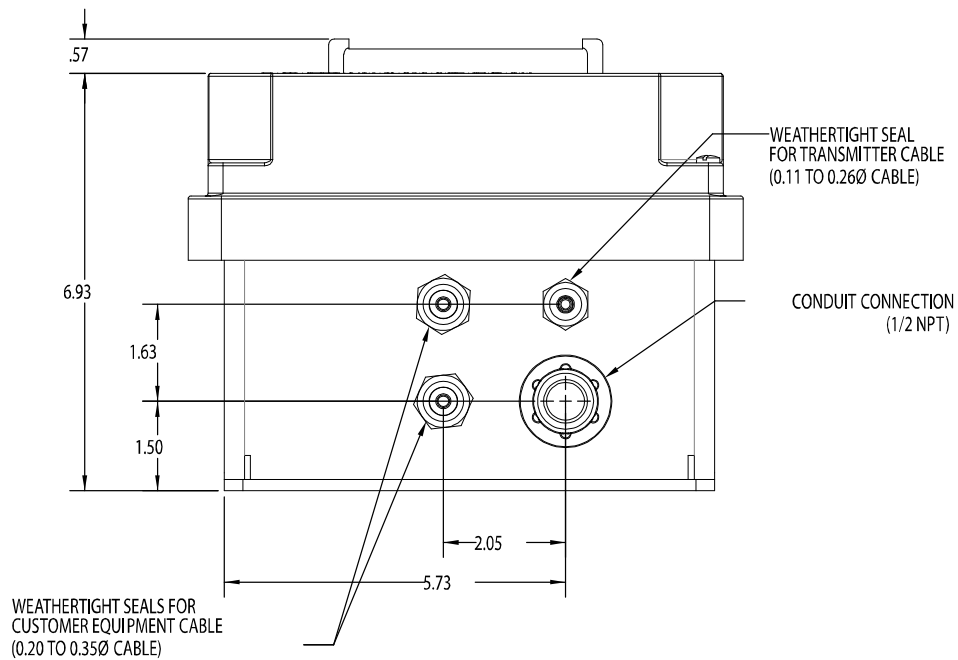
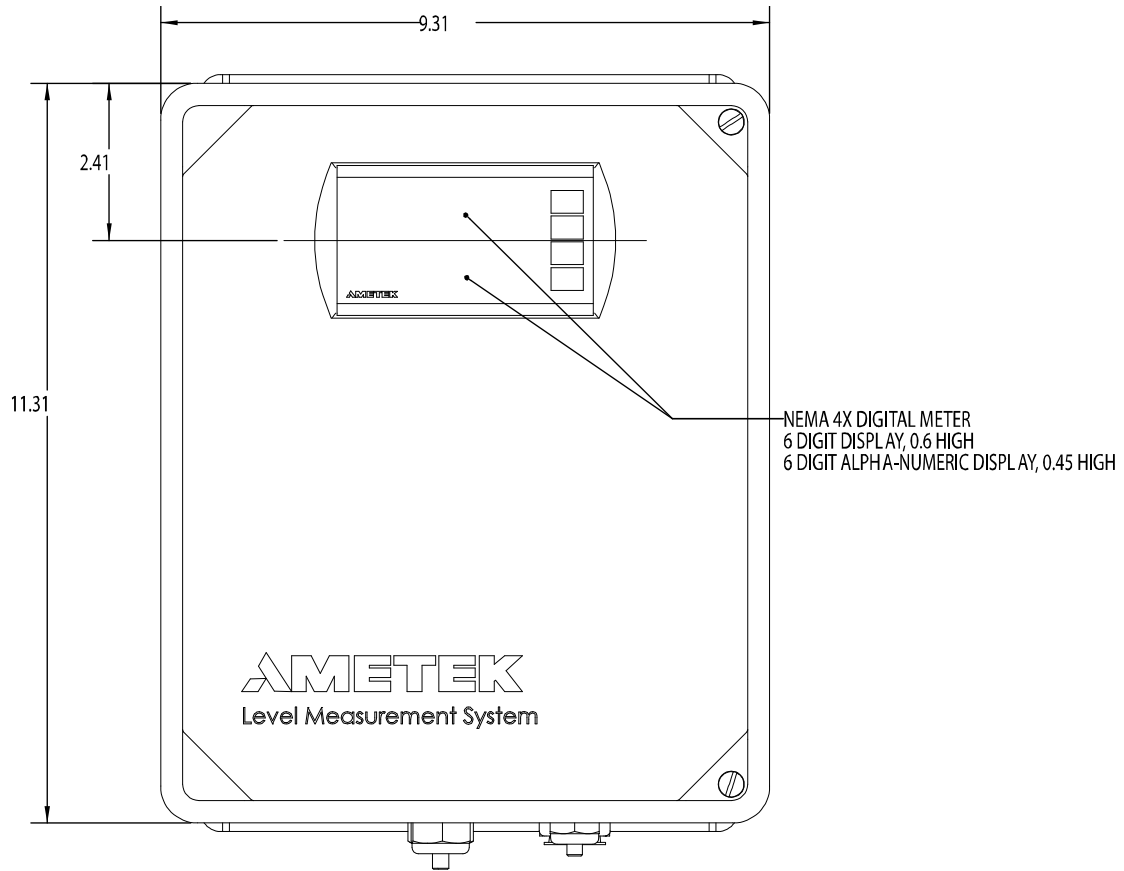

Figure 4. Meter Dimensions - Top View

Enclosure Dimensions



"1" HOUSING OPTION

Installation Overview

We recommend the following sequence for getting the meter into service:

1. **DO NOT** apply AC or DC power to the meter.
2. Connect the meter to the PC with the USB cable provided. **DO NOT** use a different USB cable.
3. If DDMC Meter View is already installed in your computer, then the program will launch automatically in most systems. If the program does not start automatically, double-click on the MVPro icon.
4. If MVPro is not installed, follow the instructions provided below.
5. Use MVPro to configure the meter for your application.
6. Disconnect the USB cable from the meter.
7. Apply power and signal and check operation of the meter.
8. Install the meter and put into service.
9. Make any programming adjustments using the front panel buttons.

DDMC Meter View Software

The easiest and quickest way to program your meter is to use the FREE DDMC Meter View programming software. This software is loaded into the meter and connects and installs directly to your PC with the USB cable provided. **DO NOT** use a different USB cable. We recommend that the first thing you do after taking the meter out of the box is connect the meter to your PC with the provided USB cable. **DO NOT** apply AC or DC power to the meter while your PC is connected to the meter as it will disrupt the USB connection. It is not necessary to apply an input signal.

DDMC Meter View programming software is intuitive, and most customers can get their meter programmed as they like without even looking in the manual.

DDMC Meter View Installation

1. Connect one end of the provided USB cable to the meter and the other end to the computer. The computer will automatically install the driver software it needs to talk to the meter. Follow the on-screen instructions and allow sufficient time for the process to complete. This can take a few minutes. If the process is interrupted, then it could leave the system in an unstable condition.

⚠ WARNINGS

- Only one meter may be connected at a time. Attaching multiple meters will cause a conflict with the meter software.
- **DO NOT** apply AC or DC power to the meter when using the Micro USB connection.

2. Once the driver is installed, an AutoPlay dialog should appear for the drive "MAINSTAL." Click "Open folder to view files."

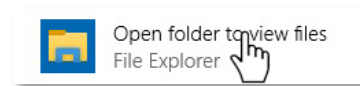

If the computer does not display an AutoPlay dialog for the drive "MAINSTAL," you should open My Computer and double-click on the drive labeled "MAINSTAL."

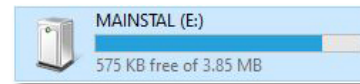

3. Double-click on the file named "MAStart." The program will open a few windows and install two programs on your computer. Simply follow the on-screen instructions until you see one of the dialogs below. If you receive a "User Account Control" warning, click "Yes."

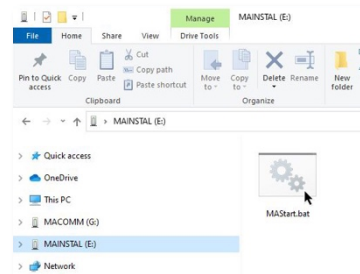

4. If there is an update available, click the "Update" button to install the new version. Otherwise, click "Configure" to begin programming your meter.

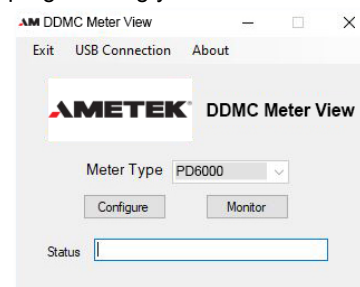

Note: If you decide to update your DDMC Meter View software, once the installation has completed, you will be asked if you want to update the setup files located on the meter itself. This way, you will always have the most current version on the meter for future installs.

⚠ WARNING

- **DO NOT** unplug the meter while the new installation files are being written to it. The meter will display μsr to E during the process and you will receive an on-screen notification once the process is complete.

Transmitter Supply Voltage Selection (P+, P-)

All meters, including models equipped with the 12-24 VDC power option, are shipped from the factory configured to provide 24 VDC power for the transmitter or sensor.

If the transmitter requires 5 or 10 VDC excitation, the internal jumper J4 must be configured accordingly.

To access the voltage selection jumper:

1. Remove all the wiring connectors.
2. Unscrew the back cover.
3. Slide out the back cover by about 1 inch.
4. Configure the J4 jumper, located behind the input signal connector, for the desired excitation voltage as shown.

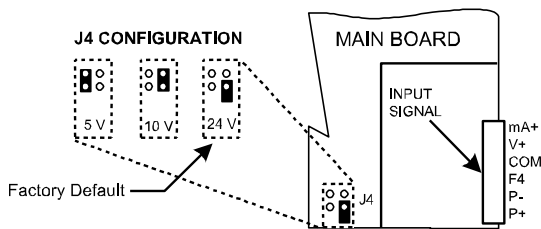

Figure 5. Transmitter Supply Voltage Selection

Connections

All connections are made to removable screw terminal connectors located at the rear of the meter.

- CAUTION**
- Use copper wire with 60°C or 60/75°C insulation for all line voltage connections. Observe all safety regulations. Electrical wiring should be performed in accordance with all applicable national, state, and local codes to prevent damage to the meter and ensure personnel safety.

Connectors Labeling

The connectors' label, affixed to the meter, shows the location of all connectors available with requested configuration.

Note: ## on the following figures refers to power and display options. (Example: PD6000-6H5-DB)

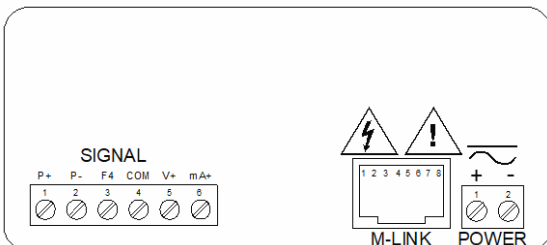

Figure 6. PD6000-##0-DB Connectors Label

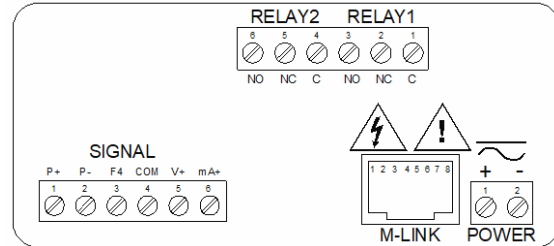

Figure 7. PD6000-##2-DB Connectors Label

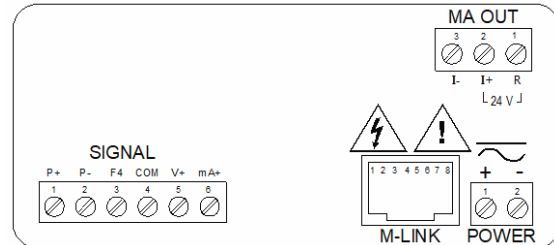

Figure 8. PD6000-##3-DB Connectors Label

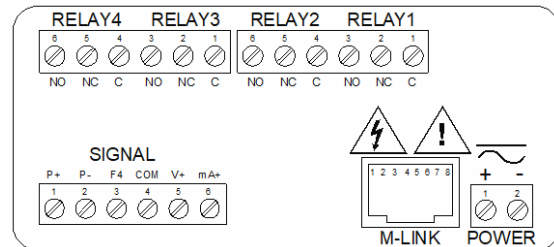

Figure 9. PD6000-##4-DB Connectors Label

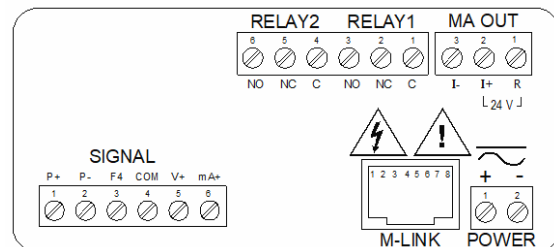

Figure 10. PD6000-##5-DB Connectors Label

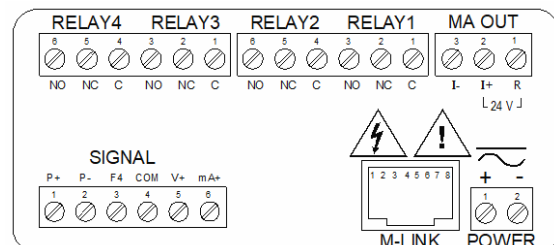
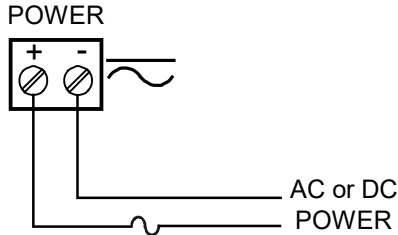

Figure 11. PD6000-##7-DB Connectors Label

- WARNING**
- **DO NOT** connect any equipment other than AMETEK's expansion modules, cables, or meters to the RJ45 M LINK connector. Otherwise damage will occur to the equipment and the meter.

Power Connections

Power connections are made to a two-terminal connector labeled POWER. The meter will operate regardless of DC polarity connection. The + and - symbols are only a suggested wiring convention.



Required External Fuse:
5 A max, 250 V Slow Blow

Figure 12. Power Connections

Signal Connections

Signal connections are made to a six-terminal connector labeled SIGNAL. The COM (common) terminal is the return for the 4-20 mA and the ±10 V input signals.

Current (mA) Connections

The following figures show examples of current connections. There are no switches or jumpers to set up for current inputs. Setup and programming is performed through the front panel buttons.

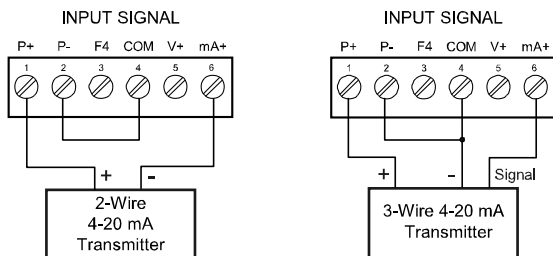

Figure 13. Transmitters Powered by Internal Supply

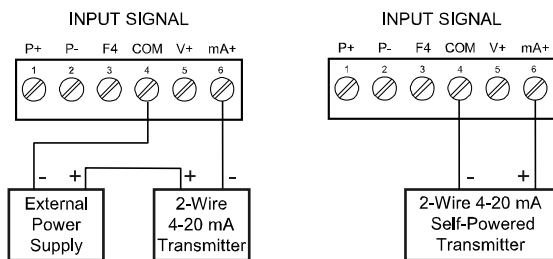

Figure 14. Transmitter Powered by External Supply or Self-Powered

The current input is protected against current overload by a resettable fuse. The display may or may not show a fault condition depending on the nature of the overload. The fuse limits the current to a safe level when it detects a fault condition, and automatically resets itself when the fault condition is removed.

Voltage (V) Connections

The following figures show examples of voltage connections. There are no switches or jumpers to set up for voltage inputs. Setup and programming is performed through the front panel buttons.

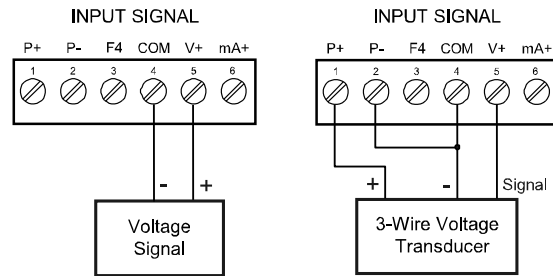

Figure 15. Voltage Input Connections

The meter is capable of accepting any voltage from -10 VDC to +10 VDC.

Modbus RTU Serial Communications

Serial communications connection is made to an RJ45 connector labeled M-LINK. For interfacing to the DDMC, use the PDA1232 for RS-232 or the PDA1485 for RS-485. The same port is used for interfacing with all expansion modules (e.g. external relays, digital I/O).

Relay Connections

Relay connections are made to two six-terminal connectors labeled RELAY1 – RELAY4. Each relay's C terminal is common only to the normally open (NO) and normally closed (NC) contacts of the corresponding relay. The relays' C terminals should not be confused with the COM (common) terminal of the INPUT SIGNAL connector.

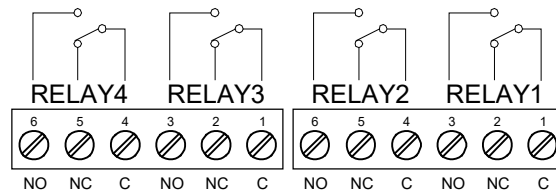

Figure 16. Relay Connections

Switching Inductive Loads

The use of snubbers to suppress electrical noise is strongly recommended when switching inductive loads to prevent disrupting the microprocessor's operation. The snubbers also prolong the life of the relay contacts. Suppression can be obtained with resistor-capacitor (RC) networks assembled by the user or purchased as complete assemblies. Refer to the following circuits for RC network assembly and installation:

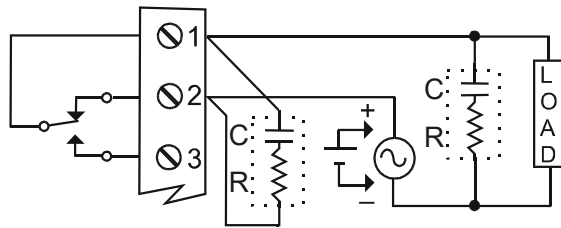

Figure 17. AC and DC Loads Protection

Choose R and C as follows:

R: 0.5 to 1 Ω for each volt across the contacts

C: 0.5 to 1 μF for each amp through closed contacts

Notes:

1. Use capacitors rated for 250 VAC.
2. RC networks may affect load release time of solenoid loads. Check to confirm proper operation.
3. Install the RC network at the meter's relay screw terminals. An RC network may also be installed across the load. Experiment for best results.

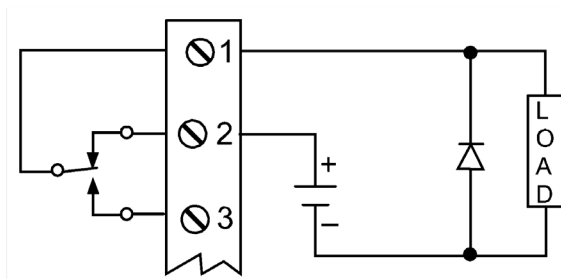

Use a diode with a reverse breakdown voltage two to three times the circuit voltage and forward current at least as large as the load current.

Figure 18. Low Voltage DC Loads Protection

RC Networks (Snubbers) Available from AMETEK

RC networks are available from AMETEK and should be applied to each relay contact switching an inductive load.

Note: Relays are de-rated to 1/14th HP (50 watts) with an inductive load.

F4 Digital Input Connections

A digital input, F4, is standard on the meter. This digital input should be connected with a normally open contact across F4 and COM, or with an active low signal applied to F4. It can be used for remote operation of front-panel buttons, to acknowledge/reset relays, or to reset max/min values. See *Function Keys & Digital I/O Available Settings* on page 41 for a complete list of capabilities.

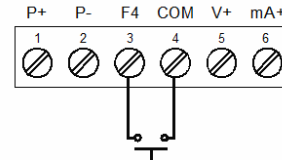

Figure 19. F4 Digital Input Connections

4-20 mA Output Connections

Connections for the 4-20 mA transmitter output are made to the connector terminals labeled mA OUT. The 4-20 mA output may be powered internally or from an external power supply.

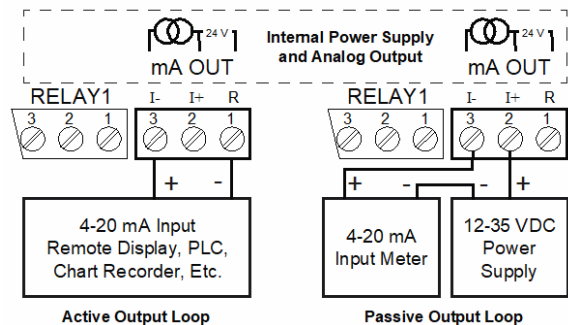

Figure 20. 4-20 mA Output Connections

Analog Output Power Supply

The internal 24 VDC power supply powering the analog output may be used to power other devices if the analog output is not used. The I+ terminal is the +24 V and the R terminal is the return.

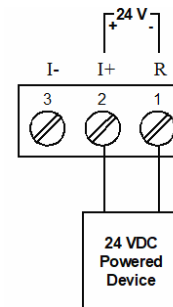

Figure 21. Analog Output Supply Powering Other Devices

External Relays Connections

The relay expansion module PDA1004-DB is connected to the meter using a CAT5 cable provided with each module. The two RJ45 connectors on the expansion modules are identical and interchangeable; they are used to connect additional modules to the system.

⚠ WARNING

- **DO NOT** connect or disconnect the expansion modules with the power on! More detailed instructions are provided with each optional expansion module.

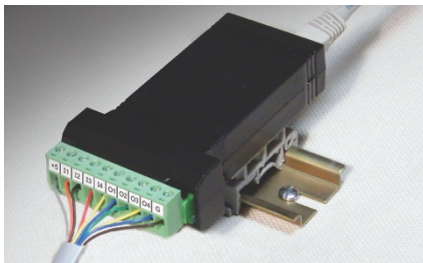

Figure 22. Expansion Module & DIN Rail Mounting Kit

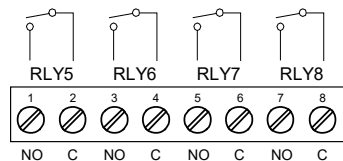

Figure 23. External Relays Module Connections

Interlock Relay Feature

As the name implies, the interlock relay feature reassigns one, or more, alarm/control relays for use as interlock relay(s). Interlock contact(s) are wired to digital input(s) and activate the interlock relay. This feature is enabled by configuring the relay, and the corresponding digital input(s), see *Setting Up the Interlock Relay (Force On) Feature* on page 34.

In the example below, an Interlock Contact switch is connected to a digital input, which will be used to force on (energize) the Interlock Relay. The Interlock Relay and the Control Relay are connected in series with the load.

- When the Interlock Contact is closed (safe), the Interlock Relay energizes, allowing power to flow to the Control Relay; the corresponding front panel LED is on.
- When the Interlock Contact is open, the corresponding front panel LED flashes (locked out), the Interlock Relay is de-energized, preventing power from flowing to the Control Relay and the load.

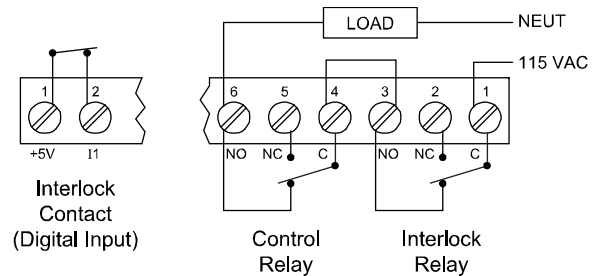

Figure 24. Interlock Connections

Setup and Programming

There is **no need to recalibrate** the meter when first received from the factory. The meter is **factory calibrated** prior to shipment for milliamps and volts with calibration equipment that is certified to NIST standards.

Overview

There are no jumpers to set for the meter input selection. Setup and programming is done using DDMC Meter View or through the front panel buttons. After power and input signal connections have been completed and verified, apply power to the meter.

Front Panel Buttons and Status LED Indicators



Button Symbol	Description
	Menu
	Right arrow/F1
	Up arrow/F2
	Enter/F3
<p><i>Note:</i> F4 is a digital input. Alarms 5-8 are enabled when relay expansion module is installed.</p>	

LED	Status
1-8	Alarm 1-8 indicator
1-8 M	Flashing: Relay in manual control mode
T	Flashing: Tare
1-8	Flashing: Relay interlock switch open
<p><i>Note:</i> LEDs for relays in manual mode flash with the "M" LED every 10 seconds. "M" flashing by itself indicates Aout – manual control is used.</p>	

- Press the Menu button to enter or exit the Programming Mode at any time.
- Press the Right arrow button to move to the next digit during digit or decimal point programming.
- Press or hold the Up arrow button to scroll through the menus, decimal point, or to increment the value of a digit.
- Press the Enter button to access a menu or to accept a setting.
- Press and hold the Menu button for three seconds to access the advanced features of the meter.

Display Functions & Messages

The meter displays various functions and messages during setup, programming, and operation. The following table shows the main menu functions and messages in the order they appear in the menu.

Display Functions & Messages		
Display	Parameter	Action/Setting Description
ሀይቲዮዎ	Setup	Enter Setup menu
ከጎህቲ	Input	Enter Input selection menu
ጠጠጠ	4-20 mA	Set meter for 4-20 mA input
ህዕቲ	0-10 VDC	Set meter for ±10 VDC input
ደ-ሀርጸጸ	Dual-scale	Press Enter to select dual-scale display for some level applications (Select Yes or No)
ህጠጠ5	Units	Select the display units/tags
ደፎር ስፔት	Decimal point	Set decimal point
ሶህ 1	PV1	PV1 decimal point (Level)
ሶህ 2	PV2	PV2 decimal point (Level)
ሶራጠ	Program	Enter the Program menu
ሀርጸጸ	Scale	Enter the Scale menu
ሀርጸጸ 1	Scale 1	Enter the Scale menu for PV1
ሀርጸጸ 2	Scale 2	Enter the Scale menu for PV2
ርጸጸ	Calibrate	Enter the Calibration menu
ከጎህ 1	Input 1	Calibrate input 1 signal or program input 1 value
ደገገ 1	Display 1	Program display 1 value
ከጎህ 2	Input 2	Calibrate input 2 signal or program input 2 value (up to 32 points)
ደገገ 2	Display 2	Program display 2 value (up to 32 points)
ፎራራ	Error	Error, calibration not successful, check signal or programmed value
ደሀሶጸጸ	Display	Enter the Display menu
ገጠፎ 1	Display Line 1	Press Enter to assign the Main display parameter (default: PV)
ገጠፎ 2	Display Line 2	Press Enter to assign the small display parameter (default: engineering units)
ደ-ከጠጠ	Display intensity	Set display intensity level from 1 to 8
ሶፎጸጸ	Relay	Enter the Relay menu
ሶህ 1	Relay 1	Relay 1 setup

Display Functions & Messages		
Display	Parameter	Action/Setting Description
ሶርት 1	Action 1	Set relay 1 action
ሶህቲ	Automatic	Set relay for automatic reset
ሶ-ጠጠጠ	Auto-manual	Set relay for automatic & manual reset any time
ገጠፎ	Latching	Set relay for latching operation
ገጠፎ-ርጸጸ	Latching-cleared	Set relay for latching operation with manual reset only after alarm condition has cleared
ሶጠፎጠ	Alternate	Set relay for pump alternation control
ሶጠጠጠ	Sampling	Set relay for sampling operation
ፊፊፊ	Off	Disable relay and front panel status LED (Select Off to enable Interlock feature)
ሀይት 1	Set 1	Program set point 1
ሶሀት 1	Reset 1	Program reset point 1
ሶህ 2	Relay 2	Relays 2-8 setup <i>Note: Relays 5-8 are shown, only if expansion relay module is installed.</i>
ፎራሶፊ	Fail-safe	Enter Fail-safe menu
ፎራሶ 1	Fail-safe 1	Set relay 1 fail-safe operation
ጠጠ	On	Enable fail-safe operation
ፊፊፊ	Off	Disable fail-safe operation
ፎራሶ 2	Fail-safe 2	Set relays 2-8 fail-safe operation
ደፎጸጸ	Delay	Enter relay Time Delay menu
ደህ 1	Delay 1	Enter relay 1 time delay setup
ጠጠ 1	On 1	Set relay 1 On time delay
ፊፊፊ 1	Off 1	Set relay 1 Off time delay
ደህ 2	Delay 2	Enter relays 2-8 time delay setup
ፎራፎጠ	Loop break	Set relay condition if loop break detected
ጠጠጠፎ	Ignore	Ignore loop break condition (Processed as a low signal condition)
ጠጠ	On	Relay goes to alarm condition when loop break is detected
ፊፊፊ	Off	Relay goes to non-alarm condition when loop break is detected
ሶህቲ	Analog output	Enter the Analog output scaling menu

Display Functions & Messages		
Display	Parameter	Action/Setting Description
d 15 1	Display 1	Program display 1 value
Out 1	Output 1	Program output 1 value (e.g. 4.000 mA)
d 15 2	Display 2	Program display 2 value
Out 2	Output 2	Program output 2 value (e.g. 20.000 mA)
rESEt	Reset	Press Enter to access the Reset menu
rSt H	Reset high	Press Enter to reset max display
rSt Lo	Reset low	Press Enter to reset min display
rSt HL	Reset high & low	Press Enter to reset max & min displays
rSt tr	Reset tare	Reset tare
Control	Control	Enter Control menu
Auto	Automatic	Press Enter to set meter for automatic operation
MAN	Manual	Press Enter to manually control relays or analog output operation
PRSS	Password	Enter the Password menu
PRSS 1	Password 1	Set or enter Password 1
PRSS 2	Password 2	Set or enter Password 2
PRSS 3	Password 3	Set or enter Password 3
unLoc	Unlocked	Program password to lock meter
Locd	Locked	Enter password to unlock meter
999999 -99999	Flashing	Over/under range condition

Main Menu

The main menu consists of the most commonly used functions: *Setup*, *Reset*, *Control*, and *Password*.

- Press Menu button to enter Programming Mode then press the Up arrow button to scroll main menu.
- Press Menu, at any time, to exit and return to Run Mode. Changes made to settings prior to pressing Enter are not saved.
- Changes to the settings are saved to memory only after pressing Enter/F3.
- The display moves to the next menu every time a setting is accepted by pressing Enter/F3.

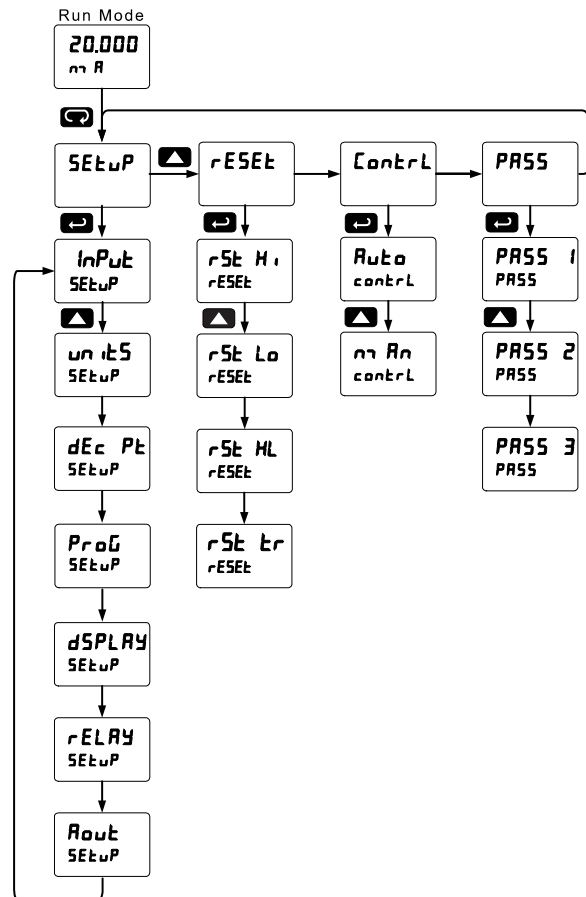

Setting Numeric Values

The numeric values are set using the Right and Up arrow buttons. Press Right arrow to select next digit and Up arrow to increment digit value. The digit being changed is displayed brighter than the rest. Press and hold Up to auto-increment the display value. If negative numbers are allowed, the first digit position will include a negative symbol (-) after the 9. Press the Enter button, at any time, to accept a setting or Menu button to exit without saving changes.

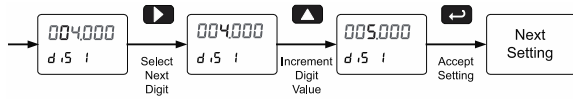

Setting Up the Meter (SEtUP)

The Setup menu is used to select:

1. Input signal the meter will accept
2. Dual-scale feature for some level applications
3. Select the display units/tags
4. Decimal point position
5. Programming Menu
6. Display parameter and intensity
7. Relay operation
8. 4-20 mA analog output scaling

Press the Enter button to access any menu or press Up arrow button to scroll through choices. Press the Menu button to exit at any time.

Setting the Input Signal (InPUt)

Enter the Input menu to set up the meter to display current (mA) or voltage (VOLT) inputs.

The current input is capable of accepting any signal from 0 to 20 mA. Select current input to accept 0-20 mA or 4-20 mA signals.

The voltage input is capable of accepting any signal from -10 to +10 VDC. Select voltage input to accept 0-5, 1-5, 0-10, or ±10 VDC signals.

After selecting mA or Volt input, d-SCALE is displayed; press Enter to select "Yes" or "No". Selecting "Yes" enables the dual-scale feature, which allows for the Scale (SCALE) and Units (UNITS) menus to be used to scale the same input in two different scales for PV1 & PV2.

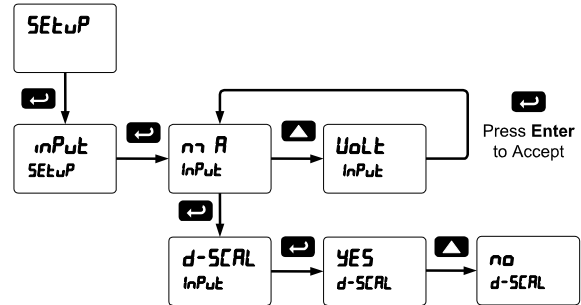

Set d-SCALE to no if only one scale is needed for the input.

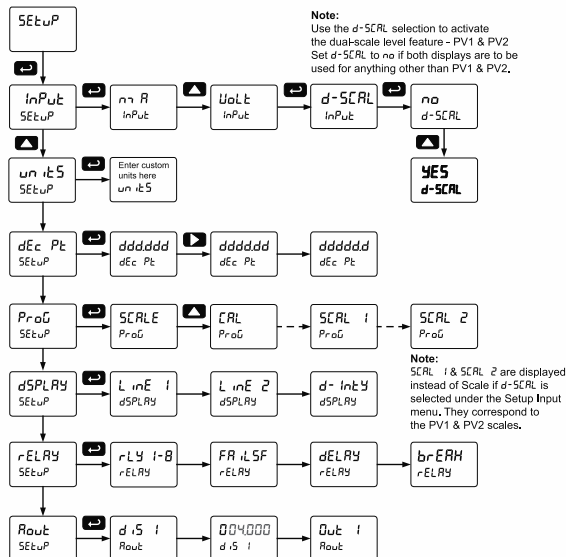

Note: Use the d-SCALE selection to activate the dual-scale level feature - PV1 & PV2. Set d-SCALE to no if both displays are to be used for anything other than PV1 & PV2.

Note: SCALE 1 & SCALE 2 are displayed instead of Scale if d-SCALE is selected under the Setup Input menu. They correspond to the PV1 & PV2 scales.

Setting the Display Units or Custom Tags (u n t5)

Enter the display unit or custom tag that will be displayed if d u n t5 is selected as the line 2 parameter. See the *Setting the Display Parameter & Intensity (d5PLR5)* flow chart on page 26 to access the display menu to show the unit or tag on display line 2. The engineering units or custom legends can be set using the following 7-segment character set:

Display	Character	Display	Character
0	0	K	K
1	1	L	L
2	2	m	m
3	3	n	n
4	4	O	O
5	5	o	o
6	6	P	P
7	7	q	q
8	8	r	r
9	9	S	S
A	A	t	t
b	b	u	u
C	C	v	V
c	c	w	w
d	d	X	X
E	E	Y	Y
F	F	Z	Z
G	G	.	.
g	g	/	/
H	H]]
h	h	[[
i	i	=	=
i	i	Degree(<)	Degree(<)
J	J	Space	Space

Notes:

Degree symbol represented by (<) if programming with DDMC Meter View.

The letters "m" and "w" use two 7-segment LEDs each; when selected the characters to the right are shifted one position.

Press and hold up arrow to auto-scroll the characters in the display.

Setting the Decimal Point (dEc Pt)

The decimal point may be set with up to five decimal places or with no decimal point at all.

The decimal point selection should be made prior to scaling, calibrating or programming the meter.

Pressing the Right arrow moves the decimal point one place to the right until no decimal point is displayed, and then it moves to the leftmost position. Pressing the Up arrow moves the decimal point one place to the left.

If the dual-scale level feature is selected, the decimal point selections for PV1 & PV2 are enabled.

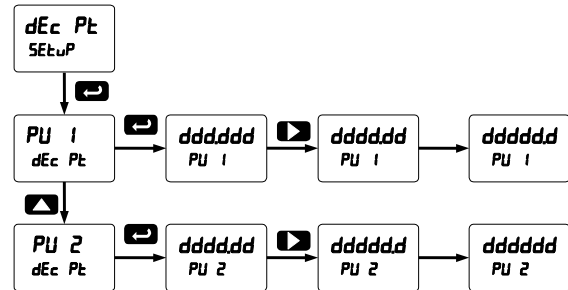

Programming the Meter (Prog)

The meter may either be scaled (SCALE) without applying an input or calibrated (CAL) by applying an input. The meter comes factory calibrated to NIST standards, so for initial setup, it is recommended to use the (SCALE) function.

The Program menu contains the Scale (SCALE) and the Calibrate (CAL) menus.

Process inputs may be scaled or calibrated to any display within the range of the meter.

The DDMC is a single input meter with dual-scale capability.

Note: The Scale and Calibrate functions are exclusive of each other. The meter uses the last function programmed. Only one of these methods can be employed at a time. The Scale and Calibrate functions can use up to 32 points (default is 2). The number of points should be set in the Advanced menu prior to scaling and calibration of the meter. See Multi-Point Linearization (LINEAR) menu on page 39 for details.

If the dual-scale level feature is selected in the Setup menu, the Scale 1 and Scale 2 menus are enabled for PV1 & PV2 respectively.

The process input may be calibrated or scaled to any display value within the range of the meter.

Program Menu for Single Scale Process

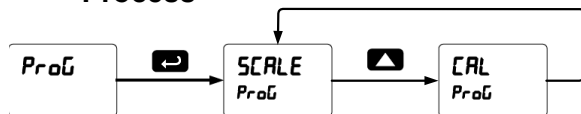

Program Menu for Dual-Scale Level Applications

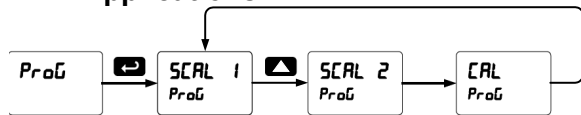

Additional parameters, not needed for most applications, are programmed in the Advanced Features menu. See Advanced Features Menu on page 37.

Multi-Point Calibration & Scaling

The meter is set up at the factory for 2-point linear calibration. The number of points for multi-point calibration/scaling is set up in the Advanced Features menu. Up to 32 linearization points may be selected for PV1 and up to 8 linearization points may be selected for PV2. See Multi-Point Linearization (LINEAR) menu on page 39 for details.

Scaling the Meter (SCALE)

The process input (4-20 mA, ±10 VDC) can be scaled to display the process variable in engineering units.

A signal source is not needed to scale the meter; simply program the inputs and corresponding display values.

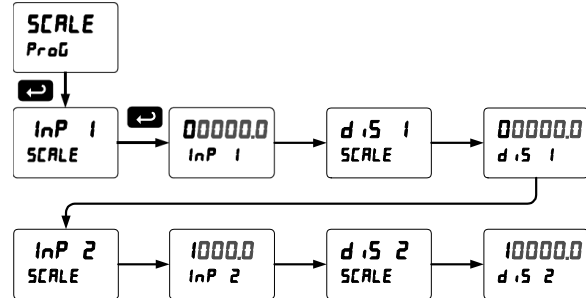

Dual-Scale for Level Applications

The analog input can be displayed in two different scales, by enabling the dual-scale feature (d-SCALE) in the Setup - Input menu. See Setting the Input Signal (INPUT) on page 22.

To enable the dual-scale feature for some level applications you must select d-SCALE in the Input selection menu.

Scaling the Input for PV1 (SCAL 1)

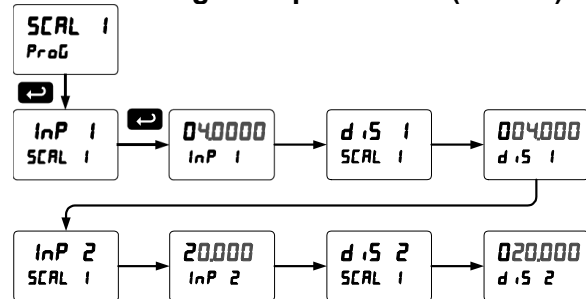

Scaling the Input for PV2 (SCAL 2)

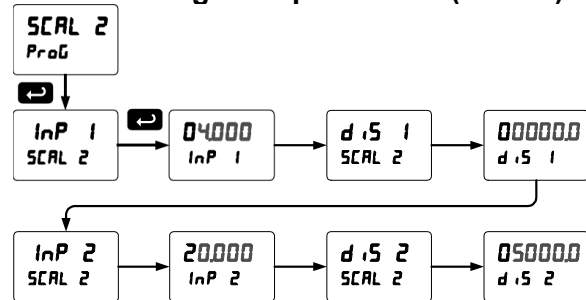

Error Message (Error)

An error message indicates that the calibration or scaling process was not successful.

After the error message is displayed, the meter reverts to the input prior to the failure during calibration or scaling and to input 1 during internal calibration, allowing the appropriate input signal to be applied or programmed.

The error message might be caused by any of the following conditions:

1. Input signal is not connected to the proper terminals or it is connected backwards*.
2. Wrong signal selection in *Setup* menu*.
3. Minimum input span requirements not maintained.
4. Input 1 signal inadvertently applied to calibrate input 2*.

**Not relevant when scaling the meter.*

For instructions on how to program numeric values see *Setting Numeric Values*, page 22.

Minimum Input Span

The minimum input span is the minimum difference between input 1 and input 2 signals required to complete the calibration or scaling of the meter.

Input Range	Input 1 & Input 2 Span
4-20 mA	0.15 mA
±10 VDC	0.10 VDC

Calibrating the Meter with External Source (CAL)

*Note: To scale the meter without a signal source refer to *Scaling the Meter (SCALE)* on page 24.*

The meter can be calibrated to display the process variable in engineering units by applying the appropriate input signal and following the calibration procedure.

The use of a calibrated signal source is strongly recommended to calibrate the meter.

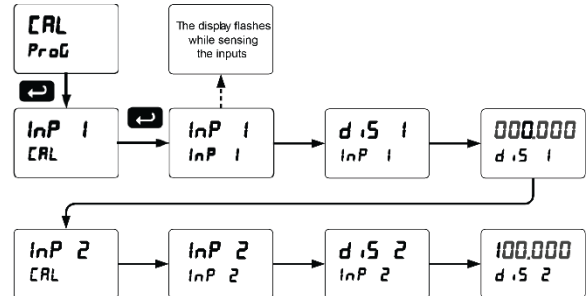

Warm up the meter for at least 15 minutes before performing calibration to ensure specified accuracy.

Setting the Display Parameter & Intensity (dSPLeRY)

The main display (L inE 1) can be programmed to display:

1. Process value 1 (PV1)
2. Process value 2 (PV2)*
3. Percent of PV1 (PCT)*
4. Relay set points
5. Max & min values
6. Modbus input
7. Display reading and units
8. Display gross
9. Toggle net & gross

The secondary display (L inE 2) can be programmed to display:

1. Unit
2. Process value 1 (PV1)
3. Process value 2 (PV2)*
4. Percent of PV1 (PCT)*
5. Relay set points
6. Max & min values
7. Engineering units or custom legends
8. Modbus input
9. Off (no display)
10. Toggle reading and units
11. Display gross
12. Toggle net/gross

*These menu items will only appear if Dual-Scale feature is turned on.

After setting up the input and display, press the Menu button to exit programming and skip the rest of the setup menu. Press the Menu button again and the Up arrow to reach the Program menu and complete the scaling or calibration of the meter.

Display Parameter Menu

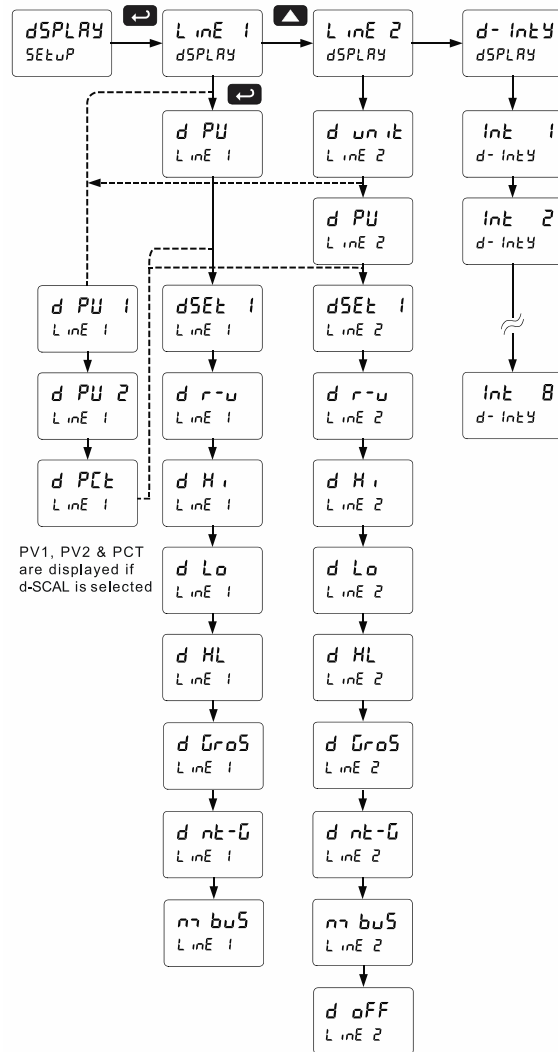

PV1, PV2 & PCT are displayed if d-SCAL is selected

Display Intensity (d- IntY)

The meter has eight display intensity levels to give the best performance under various lighting conditions. Select intensity 8 for outdoor applications. The default intensity is 6.

Display Toggling Between Reading & Units with Tag

The DDMC can be programmed so that line 1 toggles between the reading and units and line 2 displays a tag. For instance, line 1 toggles between 9500 and Gal and line 2 displays Tank 1.



Dual-Scale Display Feature

The dual-scale feature is of particular value in level applications where a second scaled display can represent the measured input in a different form (i.e. gallons & height). Both displays are independently scaled and are based on the 4-20 mA input signal.



Gallons & mA



Gallons & Height



Gallons & Percent

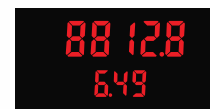

Gallons & Head PSI

Setting the Relay Operation (rELAY)

This menu is used to set up the operation of the relays.

CAUTION

- During setup, the relays do not follow the input and they will remain in the state found prior to entering the Relay menu.

- Relay action
 - Automatic reset only (non-latching)
 - Automatic + manual reset at any time (non-latching)
 - Latching (manual reset only)
 - Latching with Clear (manual reset only after alarm condition has cleared)
 - Pump alternation control (automatic reset only)
 - Sampling (the relay is activated for a user-specified time)
 - Off (relay state controlled by Interlock feature)
- Set point
- Reset point
- Fail-safe operation
 - On (enabled)
 - Off (disabled)
- Time delay
 - On delay (0-999.9 seconds)
 - Off delay (0-999.9 seconds)
- Relay action for loss (break) of 4-20 mA input (ignore, on, off)

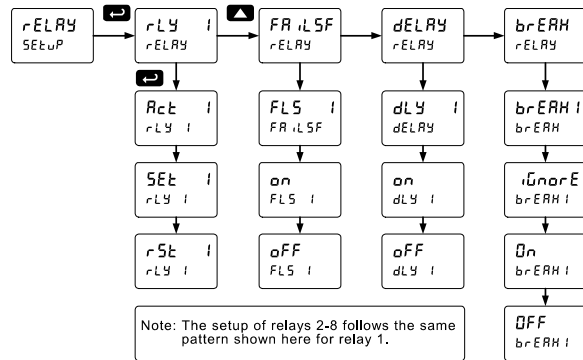

Setting the Relay Action

Operation of the relays is programmed in the *Action* menu. The relays may be set up for any of the following modes of operation:

- Automatic reset (non-latching)
- Automatic + manual reset at any time (non-latching)
- Latching (manual reset only, at any time)
- Latching with Clear (manual reset only after alarm condition has cleared)
- Pump alternation control (automatic reset only)
- Sampling (the relay is activated for a user-specified time)
- Off (relay state controlled by Interlock feature)

The following graphic shows relay 1 action setup; relay 2-8 are set up in a similar fashion.

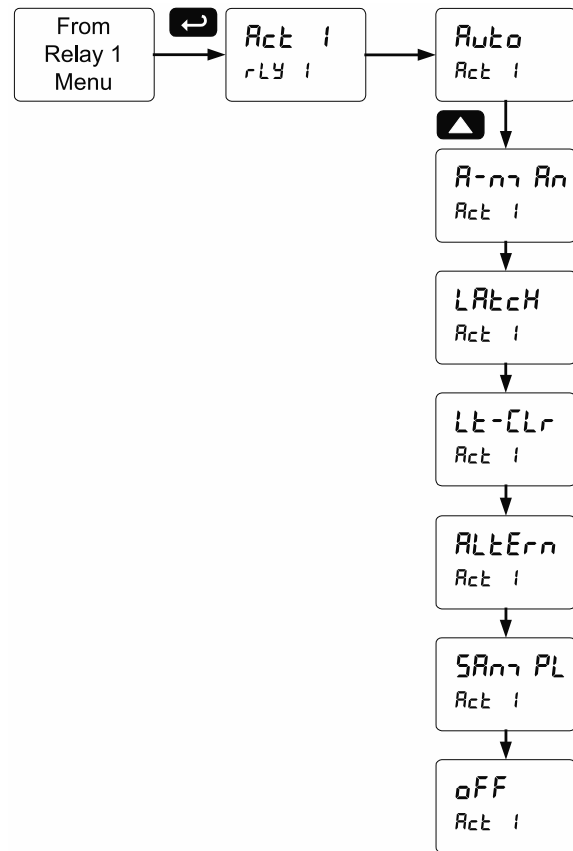

Programming Set and Reset Points

High alarm indication: program set point above reset point.

Low alarm indication: program set point below reset point.

The deadband is determined by the difference between set and reset points. Minimum deadband is one display count. If the set and reset points are programmed with the same value, the relay will reset one count below the set point.

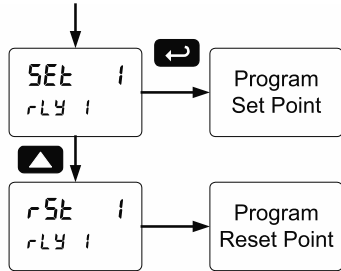

Note: Changes are not saved until the reset point has been accepted.

Setting Fail-Safe Operation

In fail-safe mode of operation, the relay coil is energized when the process variable is within safe limits and the relay coil is de-energized when the alarm condition exists. The fail-safe operation is set independently for each relay. Select **on** to enable or select **off** to disable fail-safe operation.

Programming Time Delay

The On and Off time delays may be programmed for each relay between 0 and 999.9 seconds. The relays will transfer only after the condition has been maintained for the corresponding time delay.

The On time delay is associated with the set point.

The Off time delay is associated with the reset point.

Relay Action for Loss of 4-20 mA Input (Loop Break)

A loop break condition is triggered when the 4-20 mA input signal drops below 0.005 mA. Each relay may be programmed to go to one of the following conditions when the meter detects the loss of the input signal (i.e. < 0.005 mA):

1. Turn On (Go to alarm condition)
2. Turn Off (Go to non-alarm condition)
3. Ignore (Processed as a low signal condition)

The following graph shows the loop break relay operation for a high alarm relay.

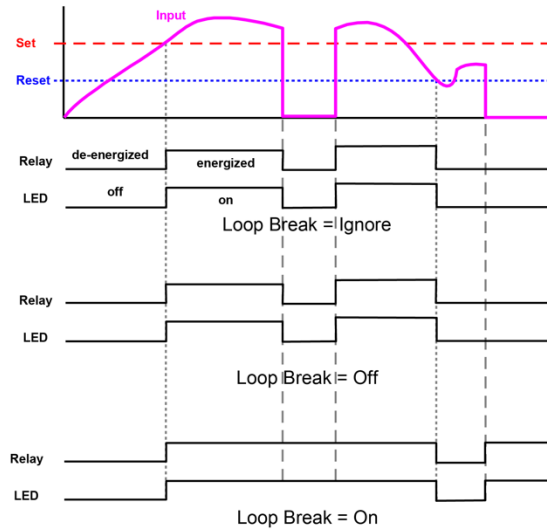

Relay and Alarm Operation Diagrams

The following graphs illustrate the operation of the relays, status LEDs, and ACK button.

High Alarm Operation (Set > Reset)

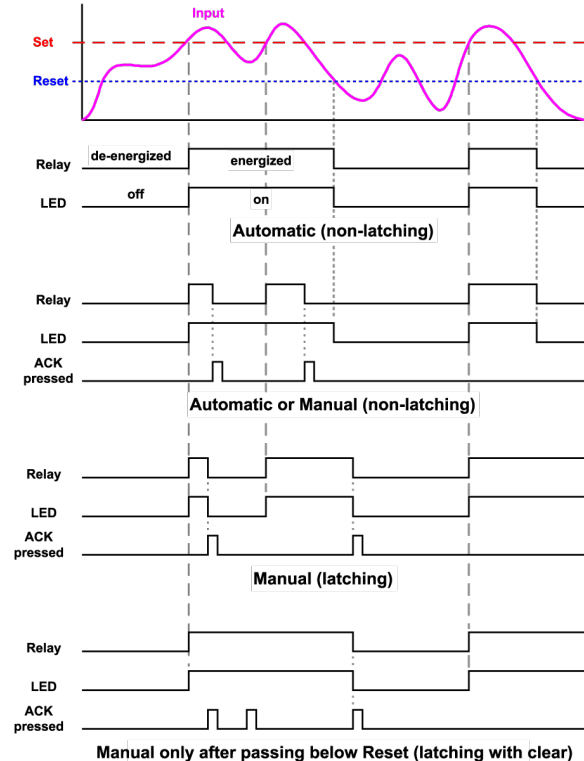

Manual only after passing below Reset (latching with clear)
For Manual reset mode, ACK can be pressed anytime to turn "off" relay. To detect a new alarm condition, the signal must go below the set point, and then go above it.

Low Alarm Operation (Set < Reset)

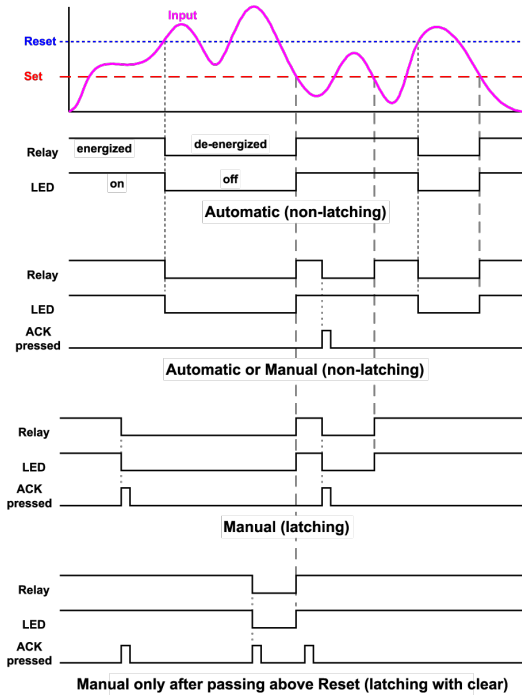

For Manual reset mode, ACK can be pressed anytime to turn "off" relay. For relay to turn back "on", signal must go above set point and then go below it.

Low Alarm with Fail-Safe Operation (Set < Reset)

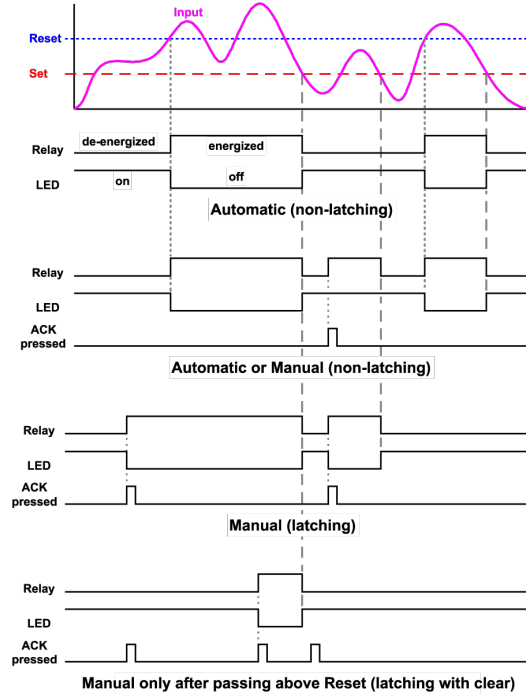

Note: Relay coil is energized in non-alarm condition. In case of power failure, relay will go to alarm state.

High Alarm with Fail-Safe Operation (Set > Reset)

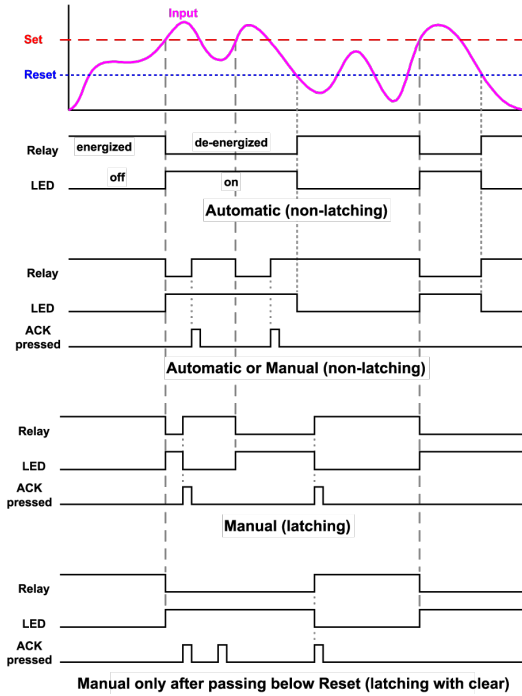

Note: Relay coil is energized in non-alarm condition. In case of power failure, relay will go to alarm state.

Time Delay Operation

The following graphs show the operation of the time delay function.

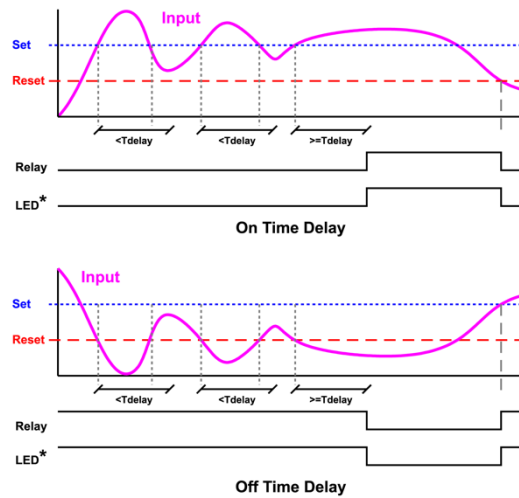

When the signal crosses the set point, the On time delay timer starts and the relay trips when the time delay has elapsed. If the signal drops below the set point (high alarm) before the time delay has elapsed, the On time delay timer resets and the relay does not change state. The same principle applies to the Off time delay.

Note: If "Automatic or Manual (R-nRn)" reset mode is selected, the LED follows the reset point and not the relay state when the relay is acknowledged.

Pump Alternation Control Operation

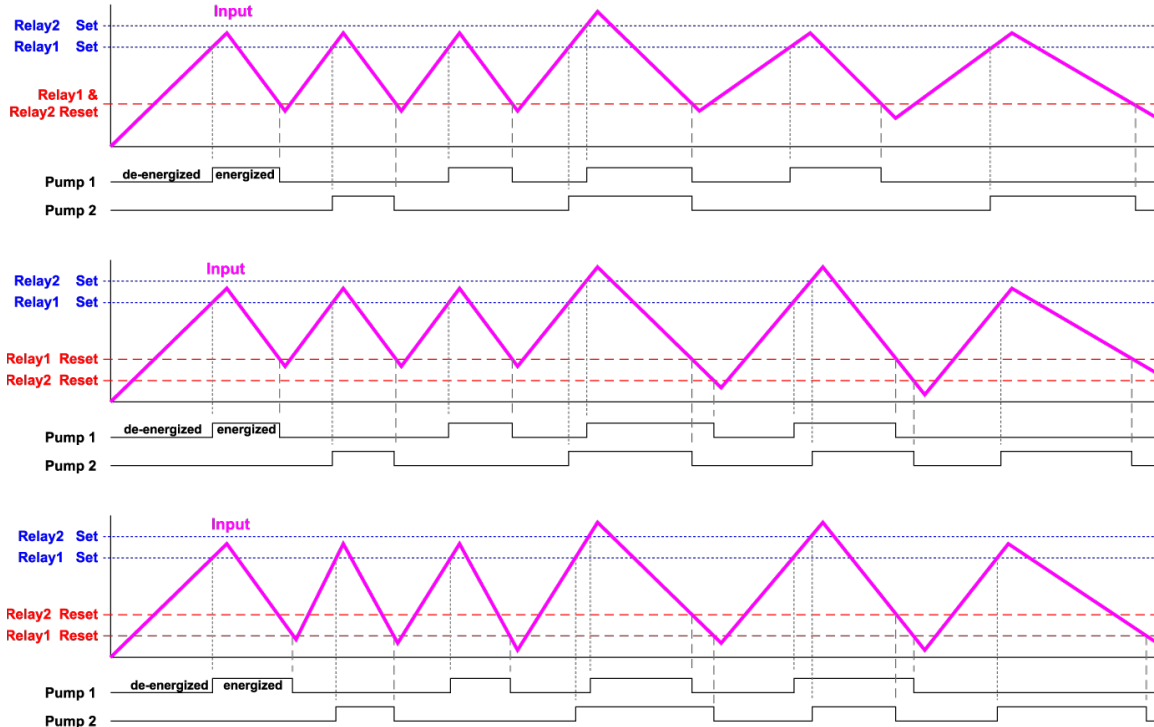

LEDs indicate the relay status

Relay Sampling Operation

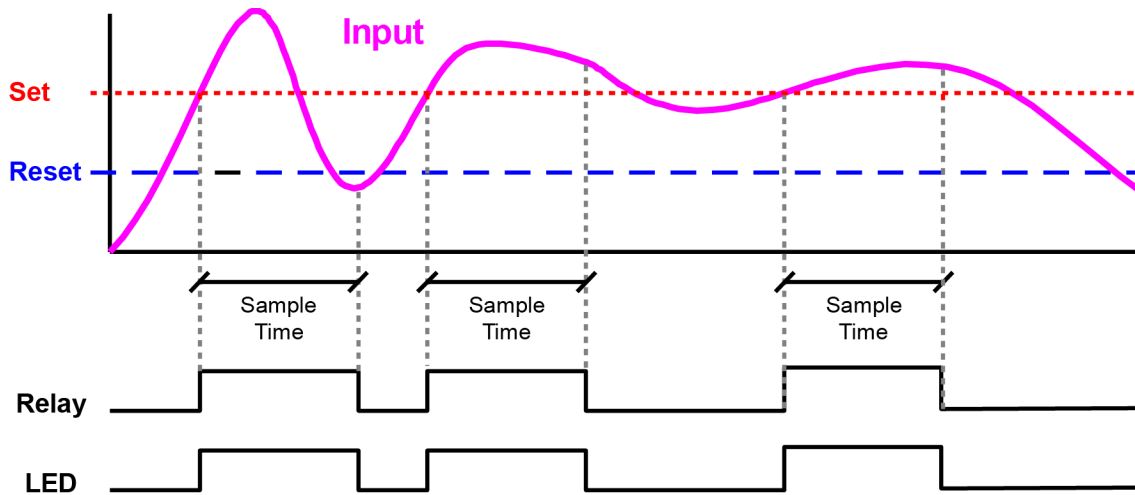

When the signal crosses the set point, the relay trips and the sample time starts. After the sample time has elapsed, the relay resets. The cycle repeats every time the set point is crossed, going up for high alarms and going down for low alarms.

The sample time can be programmed between 0.1 and 5999.9 seconds.

Relay Operation Details

Overview

The relay capabilities of the meter expand its usefulness beyond simple indication to provide users with alarm and control functions. These capabilities include front panel alarm status LEDs as well as either 2 or 4 optional internal relays and/or 4 external relays expansion module. Typical applications include high or low temperature, level, pressure or flow alarms, control applications such as simple on/off pump control, and pump alternation control for up to 8 pumps. There are four basic ways the relays can be used:

1. High or Low Alarms with Latching or Non-Latching Relays
2. Simple On/Off Control with 100% Adjustable Deadband
3. Sampling (Based on Time)
4. Pump Alternation Control for up to 8 Pumps

Relays Auto Initialization

When power is applied to the meter, the front panel LEDs and alarm relays will reflect the state of the input to the meter. The following table indicates how the alarm LEDs and relays will react on power-up based on the set and reset points:

Alarm #	HI or LO Alarm	Set Point	Reset Point	Power-Up Reading	Relay & LED
1	HI	1000	500	499	Off
2	LO	700	900	499	On
3	LO	250	400	499	Off
4	HI	450	200	499	On

Fail-Safe Operation

The following table indicates how the relays behave based on the fail-safe selection for each relay:

Fail-Safe Selection	Non-Alarm State		Alarm State		Power Failure
	NO	NC	NO	NC	
Off	Open	Closed	Closed	Open	Relays go to non-alarm state
On	Closed	Open	Open	Closed	Relays go to alarm state

*Note: NO = Normally Open, NC = Normally Closed.
This refers to the condition of the relay contacts when the power to the meter is off.*

Front Panel LEDs

The LEDs on the front panel provide status indication for the following:

LED	Status	LED	Status
1	Alarm 1	5	Alarm 5
2	Alarm 2	6	Alarm 6
3	Alarm 3	7	Alarm 7
4	Alarm 4	8	Alarm 8

The meter is supplied with four alarm points that include front panel LEDs to indicate alarm conditions. This standard feature is particularly useful for alarm applications that require visual-only indication. The LEDs are controlled by the set and reset points programmed by the user. When the display reaches a set point for a high or low alarm, the corresponding alarm LED will turn on. When the display returns to the reset point the LED will go off. The front panel LEDs respond differently for latching and non-latching relays.

For non-latching relays, the LED is always off during normal condition and always on during alarm condition, regardless of the state of the relay (e.g. Relay acknowledged after alarm condition).

For latching relays, the alarm LEDs reflect the status of the relays, regardless of the alarm condition. The following tables illustrate how the alarm LEDs function in relation to the relays and the acknowledge button (Default: F3 key assigned to ACK).

Latching and Non-Latching Relay Operation

The relays can be set up for latching (manual reset) or non-latching (automatic reset) operation.

Relay terminology for following tables	
Terminology	Relay Condition
On	Alarm (Tripped)
Off	Normal (Reset)
Ack	Acknowledged

The On and Off terminology does not refer to the status of the relay's coil, which depends on the fail-safe mode selected.

WARNING

- In latching relay mode, if Fail-Safe is off, latched relays will reset (unlatch) when power is cycled.

Non-Latching Relay (ብህቲዕ)

In this application, the meter is set up for automatic reset (non-latching relay). Acknowledging the alarm while it is still present has no effect on either the LED or the relay. When the alarm finally goes away, the relay automatically resets and the LED also goes off.

Automatic reset only		
Condition	LED	Relay
Normal	Off	Off
Alarm	On	On
Ack (No effect)	On	On
Normal	Off	Off

Non-Latching Relay with Manual Reset (ብ-ብገብብ)

In this application, the meter is set up for automatic and manual reset at any time (non-latching relay). The LED and the relay automatically reset when the meter returns to the normal condition.

In addition, the relay can be manually reset while the alarm condition still exists, but the LED will stay on until the meter returns to the normal condition.

Automatic + manual reset at any time		
Condition	LED	Relay
Normal	Off	Off
Alarm	On	On
Normal	Off	Off
Next Alarm	On	On
Ack	On	Off
Normal	Off	Off

Latching Relay (ጌብኒርዞ)

In this application, the meter is set up for manual reset at any time. Acknowledging the alarm even if the alarm condition is still present resets the relay and turns off the LED.

Manual reset any time		
Condition	LED	Relay
Normal	Off	Off
Alarm	On	On
Ack	Off	Off

Latching Relay with Clear (ጌኒ-ጌር)

In this application, the meter is set up for manual reset only after the signal passes the reset point (alarm condition has cleared). Acknowledging the alarm while it is still present has no effect on either the LED or the relay. When the alarm is acknowledged after it returns to the normal state, the LED and the relay go off. Notice that the LED remains on, even after the meter returns to the normal condition. This is because, for latching relays, the alarm LED reflects the status of the relay, regardless of the alarm condition.

Manual reset only after alarm condition has cleared		
Condition	LED	Relay
Normal	Off	Off
Alarm	On	On
Ack (No effect)	On	On
Normal	On	On
Ack	Off	Off

Acknowledging Relays

There are three ways to acknowledge relays programmed for manual reset:

1. Via the programmable front panel function keys F1-F3 (Example: F3 assigned to ACK).

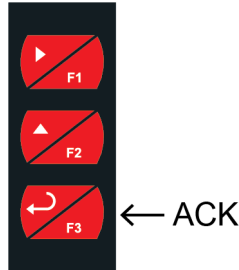

2. Remotely via a normally open pushbutton wired to the F4 terminal at the rear of the instrument.

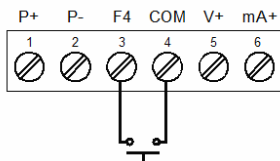

3. One of the digital inputs and the +5 V terminals on the digital I/O expansion module.

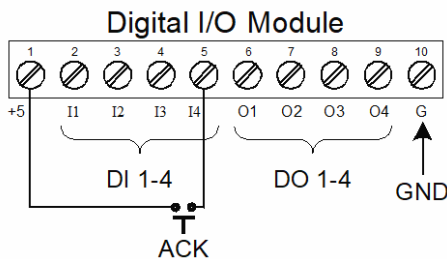

When the ACK button or the assigned digital input is closed, all relays programmed for manual reset are acknowledged.

Pump Alternation Control Applications (ALTERN)

For pump control applications where two or more similar pumps are used to control the level of a tank or a well, it is desirable to have all the pumps operate alternately. This prevents excessive wear and overheating of one pump over the lack of use of the other pumps.

Up to 8 relays can be set up to alternate every time an on/off pump cycle is completed. The set points and reset points can be programmed, so that the first pump on is the first pump off.

Application #1: Pump Alternation Using Relays 1 & 2

1. Relays 1 and 2 are set up for pump alternation.
2. Relays 3 and 4 are set up for low and high alarm indication.

Set and Reset Point Programming			
Relay	Set Point	Reset Point	Function
1	30.000	10.000	Controls pump #1
2	35.000	5.000	Controls pump #2
3	4.000	9.000	Controls low alarm
4	40.000	29.000	Controls high alarm

Pump Alternation Operation

1. Pump #1 turns on when level reaches 30.000, when level drops below 10.000, pump #1 turns off.
2. The next time level reaches 30.000, pump #2 turns on, when level drops below 10.000, pump #2 turns off.
3. If the level doesn't reach 35.000, pump #1 and pump #2 will be operating alternately.
4. If pump #1 cannot keep the level below 35.000, pump #2 will turn on at 35.000, then as the level drops to 10.000, pump #1 turns off, pump #2 is still running and shuts off below 5.000.
5. Notice that with the set and reset points of pump #2 outside the range of pump #1, the first pump on is the first pump to go off. This is true for up to 8 alternating pumps, if setup accordingly.
6. Relay #3 will go into alarm if the level drops below 4.000 and relay #4 will go into alarm if the level exceeds 40.000.
7. Adding the 4 external relays, expansion module allows using the 4 SPDT internal relays for pump alternation and the 4 SPST external relays for high, high-high, low, and low-low alarm indication.

Application #2: Pump Alternation Using Relays 3 & 4

1. Relays 1 and 2 are set up for low and high alarm indication.
2. Relays 3 and 4 are set up for pump alternation.

Set and Reset Point Programming			
Relay	Set Point	Reset Point	Function
1	495	750	Controls low alarm
2	7500	6900	Controls high alarm
3	7000	900	Controls backup pump
4	6000	1000	Controls main pump

The following graphics provide a visual representation of a typical pump alternation application with high and low alarm monitoring:

1. Relay #4 turns the main pump on at 6000 gallons and turns it off at 1000 gallons.

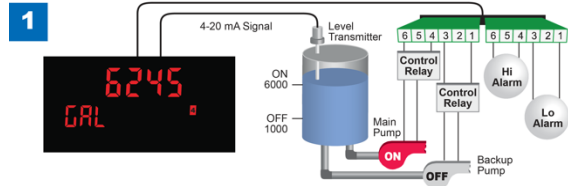

2. With the Pump Alternation feature activated, the next time the level reaches 6000 gallons, relay #3 transfers and starts the backup pump.

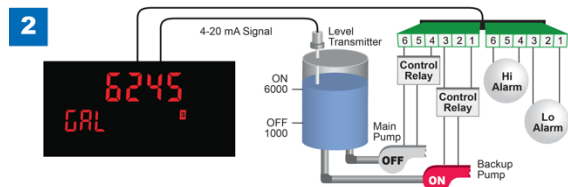

3. If the backup pump is not able to keep up, and the level reaches 7000 gallons, relay #4 transfers and starts the main pump as well.

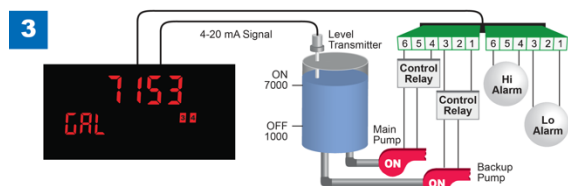

4. Relay #2 trips the High Level Alarm at 7500 gallons and resets at 6900 gallons.

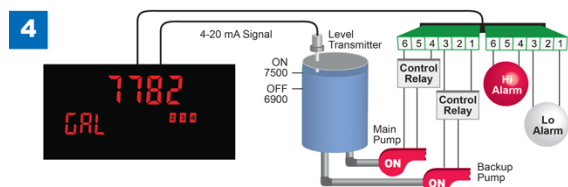

5. Relay #1 trips the Low Level Alarm at 495 gallons and resets at 750 gallons.

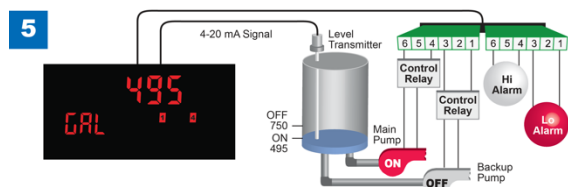

Setting Up the Interlock Relay (Force On) Feature

Relays 1-4 can be set up as interlock relays. To set up the relays for the interlock feature:

1. Access the *Setup – Relay – Action* menu and set the action to off.

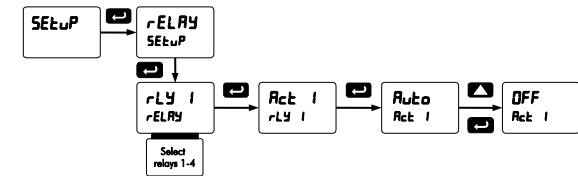

2. In the Advanced features – *User* menu program any of the digital inputs to *Force On* any of the internal relays (1-4).

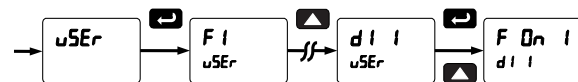

3. Connect a switch or dry contact between the +5V terminal and the corresponding digital input (dl-1 to dl-4) terminal.

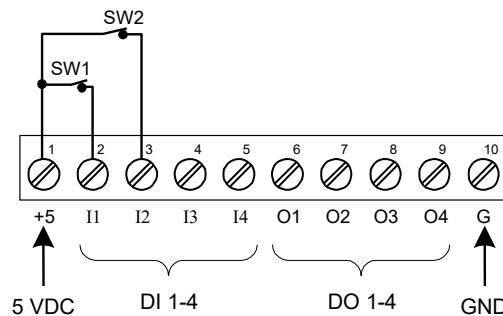

Interlock Relay Operation Example

Relays 1 & 2 are configured to energize (their front panel LEDs are steady on) when SW1 & SW2 switches (above) are closed. If the contacts to these digital inputs are opened, the corresponding front panel LEDs flash indicating this condition. The processes being controlled by the interlock relay will stop, and will re-start only after the interlock relay is re-activated by the digital inputs (switches).

Note: If multiple digital inputs are assigned to the same relay, then the corresponding logic is (AND) – i.e. both switches must be closed to activate the relay.

Scaling the 4-20 mA Analog Output (Rout)

The 4-20 mA analog output can be scaled to provide a 4-20 mA signal for any display range selected.

No equipment is needed to scale the analog output; simply program the display values to the corresponding mA output signal.

The *Analog Output* menu is used to program the 4-20 mA output based on display values.

For further details, see *Setting Numeric Values*, page 22, *Relay Action for Loss of 4-20 mA Input (Loop Break)*, page 28.

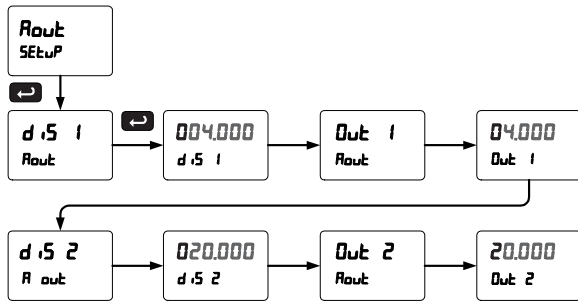

Reset Menu (rESEt)

The *Reset* menu is used to reset the maximum or minimum reading (peak or valley) reached by the process; both may be reset at the same time by selecting “reset high & low” (rSEt HL). The tare value used to zero the display may be reset by selecting “reset tare” (rSEt tr).

Manual Control Menu (Control)

The *Manual Control* menu is used to control the 4-20 mA analog output and the relays manually, ignoring the input. Each relay and analog output can be programmed independently for manual control. Selecting automatic control sets all relays and analog output for automatic operation.

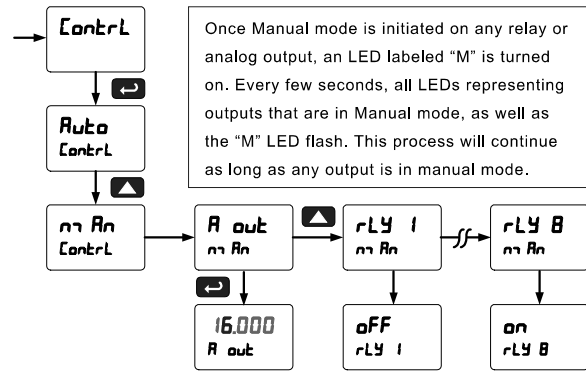

Setting Up the Password (PR55)

The *Password* menu is used for programming three levels of security to prevent unauthorized changes to the programmed parameter settings.

- Pass 1: Allows use of function keys and digital inputs
- Pass 2: Allows use of function keys, digital inputs and editing set/reset points
- Pass 3: Restricts all programming, function keys, and digital inputs.

Protecting or Locking the Meter

Enter the *Password* menu and program a six-digit password. For instructions on how to program numeric values see *Setting Numeric Values* on page 22.

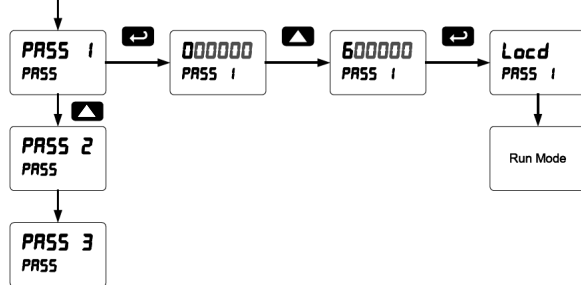

Making Changes to a Password Protected Meter

If the meter is password protected, the meter will display the message *Locd* (*Locked*) when the Menu button is pressed. Press the Enter button while the message is being displayed and enter the correct password to gain access to the menu. After exiting the programming mode, the meter returns to its password protected condition.

Disabling Password Protection

To disable the password protection, access the *Password* menu and enter the correct password twice, as shown below. The meter is now unprotected until a new password is entered.

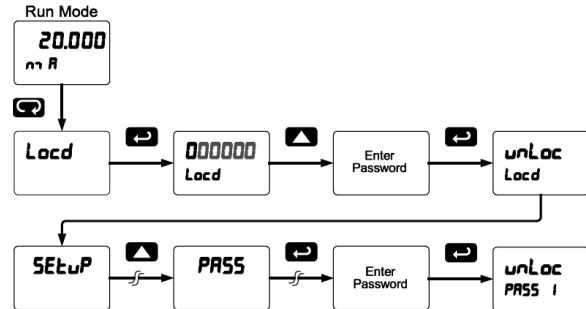

If the correct six-digit password is entered, the meter displays the message *unLoc* (*unlocked*) and the protection is disabled until a new password is programmed.

If the password entered is incorrect, the meter displays the message *Locd* (*Locked*) for about two seconds, and then it returns to Run Mode. To try again, press Enter while the *Locked* message is displayed.

Did you forget the password?

The password may be disabled by entering a master password once. If you are authorized to make changes, enter the master password 508655 to unlock the meter.

Advanced Features Menu

To simplify the setup process, functions not needed for most applications are located in the *Advanced Features* menu.

Press and hold the Menu button for three seconds to access the advanced features of the meter.

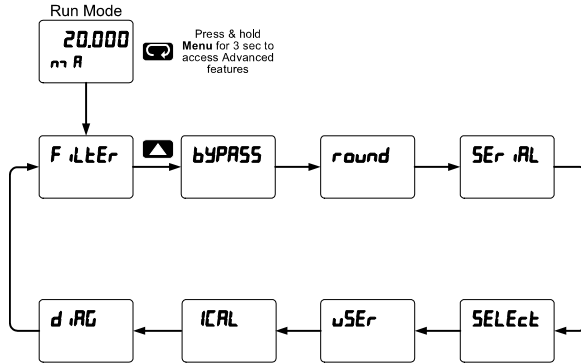

Advanced Features Menu & Display Messages

The following table shows the functions and messages of the *Advanced Features* menu in the order they appear in the menu.

Advanced Features Menu & Display Messages		
Display	Parameter	Action/Setting
FiltEr	Filter	Set noise filter value
bYPASS	Bypass	Set filter bypass value
rounD	Round	Set the rounding value for display variables
SErIAL	Serial	Set serial communication parameters
SLAVE ID	Slave ID	Set slave ID or meter address
baud	Baud rate	Select baud rate
tr dLY	Transmit delay	Set transmit delay for serial communication
PRr dLY	Parity	Select parity Even, Odd, or None with 1 or 2 stop bits
t-bYtE	Time byte	Set byte-to-byte timeout
SELEct	Select	Enter the Select menu (function, cutoff, out)
FunctiOn	Input signal conditioning	Select linear, square root, programmable exponent, or round horizontal tank function
LinEAR	Linear	Set meter for linear function and select number of linearization points
Pu 1	PV1	Select PV1 number of linearization points
Pu 2	PV2	Select PV2 number of linearization points

Advanced Features Menu & Display Messages		
Display	Parameter	Action/Setting
no Pts	Number of points	Set PV1 for 2 to 32-point linearization Set PV2 for 2 to 8-point linearization
SqURtE	Square root	Set meter for square root extraction
PrOg E	Programmable exponent	Set meter for programmable exponent and enter exponent value
rht	Round horizontal tank	Set meter for round horizontal tank volume calculation
inch	Dimension	Calculate volume in gallons
litr	Dimension	Calculate volume in liters
dIAmtr	Diameter	Enter the tank's diameter in inches
LEnGth	Length	Enter the tank's length in inches
CuTOff	Cutoff	Set low-flow cutoff
RoUtPr	Analog output programming	Program analog output parameters
SoURcE	Source	Select source for the 4-20 mA output
U-r RnG	Overrange	Program mA output for display overrange
u-r RnG	Underrange	Program mA output for display underrange
brEAK	Break	Set input break condition operation
mAx	Maximum	Program maximum mA output allowed
mIn	Minimum	Program minimum mA output allowed
CALib	Calibrate	Calibrate 4-20 mA output (internal reference source used for scaling the output)
4 mA	4 mA output	Enter mA output value read by milliamp meter with at least 0.001 mA resolution
20 mA	20 mA output	Enter mA output value read by milliamp meter with at least 0.001 mA resolution
uSER	User I/O	Assign function keys and digital I/O
F1	F1 function key	Assign F1 function key
F2	F2 function key	Assign F2 function key
F3	F3 function key	Assign F3 function key
F4	F4 function	Assign F4 function (digital input)
dI 1	Digital input 1	Assign digital input 1 – 8, if expansion modules are connected

Advanced Features Menu & Display Messages		
Display	Parameter	Action/Setting
d0 1	Digital output 1	Assign digital output 1 – 8, if expansion modules are connected
iERL	Internal source calibration	Enter internal source calibration (used for scaling the meter without a signal source)
[ERL	Current calibration	Calibrate 4-20 mA current input (internal reference source used for scaling the input)
[L o	Current low	Calibrate low current input (e.g. 4 mA)
[H i	Current high	Calibrate high current input (e.g. 20 mA)
u ERL	Voltage calibration	Calibrate voltage input
u L o	Voltage low	Calibrate low voltage input (e.g. 0 V)
u H i	Voltage high	Calibrate high voltage input (e.g. 10 V)
d .RE	Diagnostics	Display parameter settings
L E d t	LED test	Test all LEDs (press menu to exit test)
inFo	Information	Display software number and version
E r RSE	Erase	Erase DDMC Meter View SW stored in meter's memory

Noise Filter (F ILLEr)

The noise filter is available for unusually noisy signals that cause an unstable process variable display. The noise filter averages the input signal over a certain period. The filter level determines the length of time over which the signal is averaged. The filter level can be set between 2 and 199. The higher the filter level, the longer the averaging time and so the longer it takes the display to settle to its final value. Setting the filter level to zero disables the filter function.

Noise Filter Bypass (bYPRSS)

The noise filter bypass changes the behavior of the meter so that small variations in the signal are filtered out but large abrupt changes in the input signal are displayed immediately. The bypass value determines the minimum amount of signal change to be displayed immediately. All signal changes smaller than the bypass value are filtered or averaged by the meter. The noise filter bypass may be set between 0.1 and 99.9% of full scale.

Rounding Feature (round)

The rounding feature is used to give the user a steadier display with fluctuating signals. Rounding is used in addition to the filter function. Rounding causes the display to round to the nearest value according to the rounding selected. See examples below:

Rounding Selection	Actual Value	Display Value	Actual Value	Display Value
1	12.022	12.022	12.023	12.023
5	12.022	12.020	12.023	12.025
10	12.024	12.020	12.025	12.030

Modbus RTU Serial Communications (SEr iRL)

The meter is equipped with serial communications capability as a standard feature using Modbus RTU Serial Communication Protocol. The meter may be connected to a PC for initial configuration via the on-board micro USB connection. For ongoing digital communications with a computer or other data terminal equipment, an RS-232, or RS-485 option is required; see *Ordering Information* on page **Error! Bookmark not defined.** for details.

CAUTION

- **DO NOT** connect any equipment other than AMETEK's expansion modules, cables, or meters to the RJ45 M LINK connector. Otherwise damage will occur to the equipment and the meter.

Note: More detailed instructions are provided with each optional serial communications adapter.

Note: Refer to the Modbus Register Tables located at www.ametekusg.com for details.

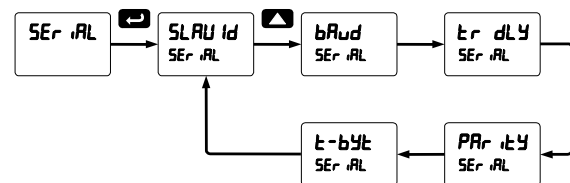

When using more than one meter in a multi-drop mode, each meter must be provided with its own unique address. The meter address (Slave ID) may be programmed between 1 and 247. The transmit delay may be set between 0 and 199 ms. The parity can be set to even, odd, or none with 1 or 2 stop bits.

Select Menu (SELEct)

The *Select* menu is used to select the input signal conditioner applied to the input (linear, square root, programmable exponent, or round horizontal tank), low-flow cutoff, and analog output programming. The multi-point linearization is part of the linear function selection.

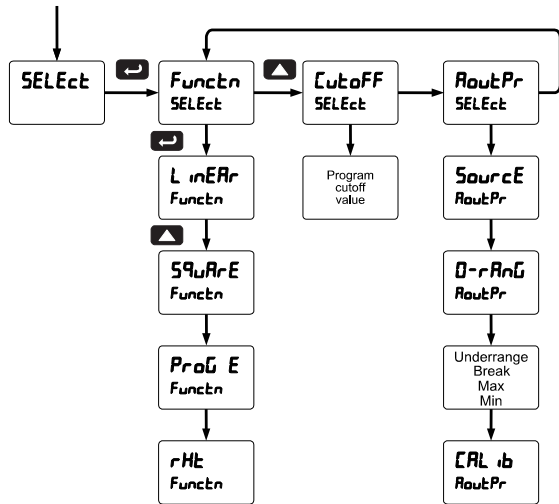

Input Signal Conditioning (Functn)

The *Function* menu is used to select the input signal conditioner applied to the input: linear, square root, programmable exponent, or round horizontal tank volume calculation. The multi-point linearization is part of the linear function selection. Meters are set up at the factory for linear function with 2-point linearization. The linear function provides a display that is linear with respect to the input signal.

Square Root Linearization (SQURrE)

The square root function can be used to linearize the signal from a differential pressure transmitter and display flow rate in engineering units.

Programmable Exponent Linearization (ProG E)

The programmable exponent can be used to linearize the signal from level transmitters in open-channel flow applications using weirs and flumes.

Multi-Point Linearization (L inERr)

Meters are set up at the factory for linear function with 2-point linearization. Up to 32 linearization points can be selected for PV1 under the linear function. The multi-point linearization can be used to linearize the display for non-linear signals such as those from level transmitters used to measure volume in odd-shaped tanks or to convert level to flow using weirs and flumes with complex exponent. If the dual-scale level feature has been selected, the menus for PV1 & PV2 are enabled. PV2 can be programmed with up to 8 linearization points.

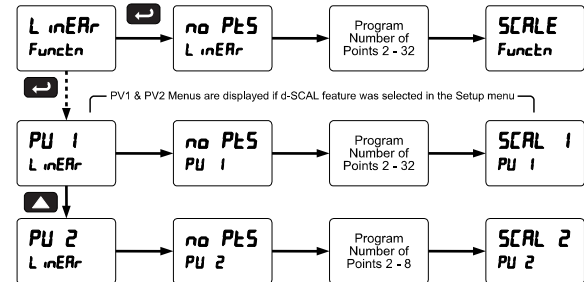

Round Horizontal Tank Linearization (rHt)

This function automatically calculates the volume in a round horizontal tank with flat ends. Set the display for the desired decimal point and engineering units before entering the round horizontal tank function. Select units, inches or cm for the tank dimensions. Enter the diameter and the length in inches and the results are calculated automatically in US gallons. Enter the diameter and length in cm and the results are calculated automatically in liters. The meter can be scaled to display the volume in any engineering unit.

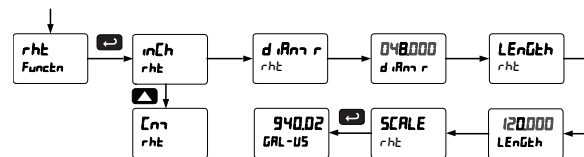

Note: After Scale is displayed continue pressing the Enter button until the meter completes the scaling of the input and display values.

Changing the Volume from Gallons to Liters

In the above graphic, entering the 48" for the diameter and 120" for the length of the round horizontal tank, the meter automatically calculates that the volume of the tank is 940.02 gallons.

1. Convert gallons to liters
1 US gallon = 3.7854 L
940.02 gal = 3558.4 L
2. Go to the *Setup* menu and change the decimal point to 1 decimal.
3. Go to the *Program – Scale* menu and press Enter until $d \cdot 5 \cdot 2$ is shown on the main display.
4. Press Enter and change the display 2 value to 3558.4.
5. The meter is now displaying the volume in liters.

Note: The display can be scaled to display the volume in any engineering units.

Another way to display the volume in liters is to enter the dimensions in cm. The meter automatically calculates the volume in liters.

Low-Flow Cutoff (עוטף)

The low-flow cutoff feature allows the meter to be programmed so that the often-unsteady output from a differential pressure transmitter, at low flow rates, always displays zero on the meter.

The cutoff value may be programmed from 0 to 999999. The meter will display zero below the cutoff value. Programming the cutoff value to zero disables the cutoff feature.

Analog Output Programming (RoutPr)

The *Analog Output Programming* menu is used to program the behavior of the 4-20 mA output. The following parameters and functions are programmed in this menu:

1. Source: Source for generating the 4-20 mA output (e.g. PV)
2. Overrange: Analog output value with display in overrange condition
3. Underrange: Analog output value with display in underrange condition
4. Break: Analog output value when loop break is detected
5. Max: Maximum analog output value allowed regardless of input
6. Min: Minimum analog output value allowed regardless of input
7. Calibrate: Calibrate the internal 4-20 mA source reference used to scale the 4-20 mA output

Analog Output Source

The source for generating the 4-20 mA output may be assigned to the process variable, maximum or minimum value reached by the process, one of the set points, or the Modbus PV input.

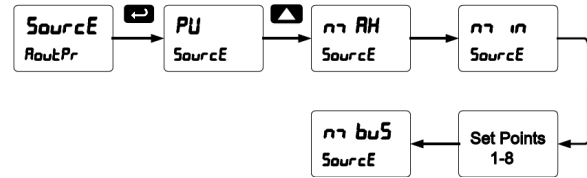

Analog Output Calibration

To perform the analog output calibration, it is recommended to use a milliamp meter with a resolution of at least 0.1 μ A to measure the output current. The values saved internally during this procedure are used for scaling the 4-20 mA output in the *Setup* menu.

Analog Output Calibration Procedure

1. Wire the DDMC 4-20 mA output to a current loop that includes a power supply (internal or external 12 to 24 VDC), and the mA input on the digital meter. See *Figure 20. 4-20 mA Output Connections* on page 17 for details.
2. Turn on all devices. Allow for a 15 to 30 minute warm-up.
3. Go to the Advanced Features menu, and navigate to the Analog Output Programming (RoutPr)/Calibration (על כו) menu and press **Enter**.
4. The display will show $4 \cdot 0 \cdot 0$. The DDMC mA output should now be close to 4 mA. Press Enter and the display will show 04.000. Enter the actual value read by the digital mA meter and press **Enter**.
5. The display will show $20 \cdot 0 \cdot 0$. The DDMC mA output should now be close to 20 mA. Press **Enter** and the display will show 20.000. Enter the actual value read by the digital mA meter and press **Enter**.
6. The meter will now calculate the calibration factors and store them.
7. Press **Menu** to exit and return to Run mode.

Programmable Function Keys User Menu (uSEr)

The User menu allows the user to assign the front panel function keys F1, F2, and F3, the digital input F4 (a digital input located on the input signal connector), and up to eight additional digital inputs to access most of the menus or to activate certain functions immediately (e.g. reset max & min, hold relay states, etc.). This allows the meter to be greatly customized for use in specialized applications.

Up to eight digital outputs can be assigned to a number of actions and functions executed by the meter (i.e. alarms, relay acknowledgement, reset max, min, or max & min, tare, and reset tare). The digital outputs can be used to trigger external alarms or lights to indicate these specific events.

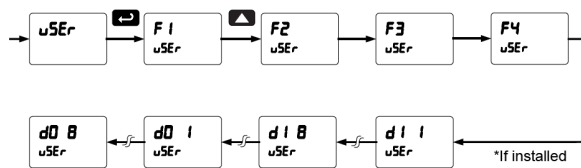

Function Keys & Digital I/O Available Settings

Refer to the following table for descriptions of each available function key or digital I/O setting.

Function Keys & Digital I/O Available Settings	
Display	Description
rSt H i	Reset the stored maximum display value
rSt Lo	Reset the stored minimum display value
rSt HL	Reset the stored maximum & minimum display values
tArE	Capture tare and zero the display
rSt tr	Reset captured tare and resume normal operation
rELAY	Directly access the relay menu
SEt i*	Directly access the set point menu for relay 1 (*through 8)
rLY d	Disable all relays until a button assigned to <i>enable relays (rLY E)</i> is pressed
rLY E	Enable all relays to function as they have been programmed
HoLd	Hold current relay states and analog output as they are until a button assigned to <i>enable relays (rLY E)</i> is pressed
d HoLd	Hold the current display value, relay states, and analog output momentarily while the function key or digital input is active. The process value will continue to be calculated in the background.
Ln i H i	Display maximum display value on line 1

Function Keys & Digital I/O Available Settings	
Display	Description
Ln i Lo	Display minimum display value on line 1
Ln i HL	Display maximum & minimum display values on line 1
Ln2 H i	Display maximum display value on line 2
Ln2 Lo	Display minimum display value on line 2
Ln2 HL	Display maximum & minimum display values on line 2
F On i*	Force relay 1 (*through 4) into the on state. This function is used in conjunction with a digital input expansion module to achieve interlock functionality. See <i>Setting Up the Interlock Relay (Force On) Feature</i> on page 34 for details.
Control	Directly access the control menu
d iSAbL	Disable the selected function key or digital I/O
RcH	Acknowledge all active relays that are in a manual operation mode such as auto-manual or latching
rESEt	Directly access the reset menu
n rEnu	Mimic the menu button functionality (digital inputs only)
r iGHt	Mimic the right arrow/F1 button functionality (digital inputs only)
uP	Mimic the up arrow/F2 button functionality (digital inputs only)
EnTEr	Mimic the enter/F3 button functionality (digital inputs only)
ALn r i*	Provide indication when alarm 1 (*through 8) has been triggered (digital outputs only)

Tare (tArE)

The tare function zero's out the display. In the case of scale weight, tare is used to eliminate container weight and provide net weight readings. There are two tare functions; Capture Tare and Reset Tare. When the capture tare function is used, the display reading is offset by the displayed amount to make the displayed value zero. This modified display value is the net value. The originally displayed value without the tare offset is the gross value. Both may be chosen as a display option.

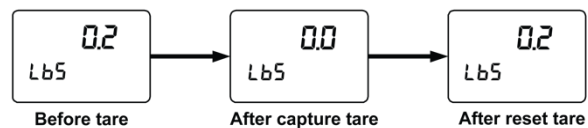

Reset tare removes the display offset of the net value, and the gross and net values become the same until a new capture tare is entered.

Internal Source Calibration (ICAL)

The meter is **factory calibrated** prior to shipment for milliamps and volts with calibration equipment that is certified to NIST standards.

The use of calibrated signal sources is necessary to calibrate the internal source of the meter. The meter's internal source is what allows the user to scale the meter without applying a signal.

Check calibration of the meter at least every 12 months. Each input must be recalibrated separately.

Notes:

1. If meter is in operation and it is intended to accept only one input type (e.g. 4-20 mA), recalibration of other input is not necessary.
2. Allow the meter to warm up for at least 15 minutes before performing the internal source calibration procedure.

The *Internal calibration* menu is part of the *Advanced Features* menu.

1. Press and hold the Menu button for three seconds to access the advanced features of the meter.
2. Press the Up arrow button to scroll to the *Internal calibration* menu (ICAL) and press Enter.
3. The meter displays either current calibration (CAL) or voltage calibration (CAL), according to the input setup. Press Enter to start the calibration process.

Example of Internal Calibration for current input:

4. The meter displays *low* input current message (Lo). Apply the low input signal and press Enter. The display flashes for a moment while the meter is accepting the low input signal.
5. After the display stops flashing, a number is displayed with the leftmost digit brighter than the rest. The bright digit is the active digit that can be changed by pressing the Up arrow button. Press the Right arrow button to move to the next digit.
6. Set the display value to correspond to the input signal being calibrated, typically 4.000 mA.
7. The display moves to the *high* input calibration (Hi). Apply the high input signal and press Enter.
8. Set the display for the high input calibration, in the same way as it was set for the low input calibration, typically 20.000 mA.

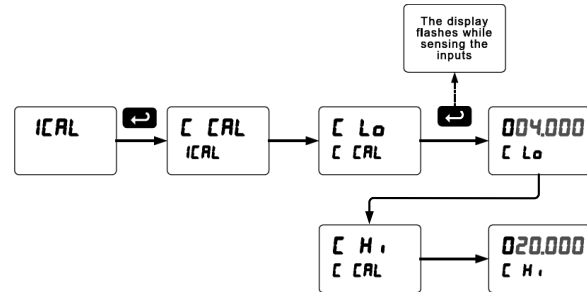

The graphic above shows the calibration of the current input. The voltage input is calibrated in a similar way.

Tips:

- Low and high input signals can be any valid values within the range of the meter.
- Observe minimum input span requirements between input 1 and input 2.
- Low input should be less than high input signal. However, the low display can be higher than the high display (i.e. 4-20 mA = 100.0 to 0.0).

Error Message (Error)

An error message indicates that the calibration or scaling process was not successful.

After the error message is displayed, the meter reverts to the input prior to the failure during calibration or scaling and to input 1 during internal calibration, allowing the appropriate input signal to be applied or programmed.

The error message might be caused by any of the following conditions:

5. Input signal is not connected to the proper terminals or it is connected backwards*.
6. Wrong signal selection in *Setup* menu*.
7. Minimum input span requirements not maintained.
8. Input 1 signal inadvertently applied to calibrate input 2*.

*Not relevant when scaling the meter.

Minimum Input Span

The minimum input span is the minimum difference between input 1 and input 2 signals required to complete the calibration or scaling of the meter.

Input Range	Input 1 & Input 2 Span
4-20 mA	0.15 mA
±10 VDC	0.10 VDC

Meter Operation

The meter is capable of accepting current (0-20 mA, 4-20 mA) and voltage signals (0-5 V, 1-5 V, 0-10 V, ± 10 V) and displaying these signals in engineering units from -99999 to 999999 (e.g. a 4-20 mA signal could be displayed as -50.000 to 50.000).

The dual-line display can be customized for the user's specific application. Typically, the main display is used for the process variable; while the second display is used for engineering units, custom legend, or set point indication.

The analog input can be scaled to display the process in two different scales; for example: with $d-S\text{RL}$ enabled, the main display could indicate level in feet and the second display could indicate the volume in gallons.

Additionally, the meter can be set up to display the analog input on the main display and the Modbus input on the second display. The relays and analog output can be programmed to operate from the Modbus PV input.

Front Panel Buttons Operation

Button Symbol	Description
	Press to enter or exit Programming Mode, view settings, or exit max/min readings
	Press to reset max/min readings or other parameter/function assigned through the <i>User</i> menu
	Press to display max/min readings or other parameter/function assigned through the <i>User</i> menu
	Press to acknowledge relays or other parameters/function assigned through the <i>User</i> menu

Function Keys Operation

During operation, the programmable function keys operate according to the way they have been programmed in the *Advanced Features – User* menu. See *Programmable Function Keys User Menu* ($\mu 5Er$) on page 41 for details.

The table above shows the factory default settings for F1, F2, and F3.

F4 Operation

A digital input, F4, is standard on the meter. This digital input is programmed identically to function keys F1, F2, and F3. The input is triggered with a contact closure to COM, or with an active low signal. During operation, F4 operates according to the way it has been programmed in the *Advanced Features – User* menu. See *Programmable Function Keys User Menu* ($\mu 5Er$) on page 41 for details.

Maximum/Minimum Readings

The max & min readings (peak & valley) reached by the process can be displayed either continuously or momentary:

1. Display briefly by assigning to the F1-F3 function keys or to the digital inputs in the *User* menu.
2. Display continuously by assigning either display to max/min through the *Display* menu.

Any of the F1-F3 function keys (buttons) and the digital inputs can be programmed to reset the max & min readings. The meters are set at the factory to display the max reading by pressing the Up arrow/F2 button and to use the Right arrow/F1 button to access the *Reset* menu.

To display max reading using function key with factory defaults:

1. Press Up arrow/F2 button to display maximum reading since the last reset/power-up.
2. To reset max/min press Right arrow/F1 button to access the *Reset* menu. The max & min displays are reset to actual values.
3. Press Menu to exit max/min display reading.

To display max/min readings continuously:

Assign either display to Max ($d H \uparrow$), Min ($d L \downarrow$), or toggle between Max and Min ($d HL$) every 10 seconds.

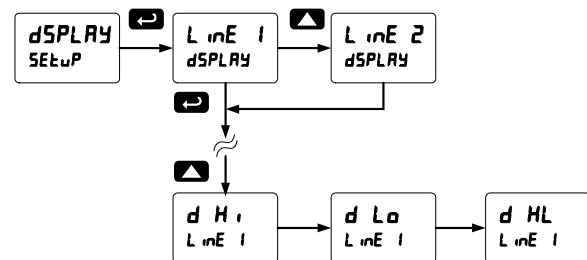

Troubleshooting

The rugged design and the user-friendly interface of the meter should make it unusual for the installer or operator to refer to this section of the manual. However, due to the many features and functions of the meter, it's possible that the setup of the meter does not agree with what an operator expects to see. If the meter is not working as expected, refer to the *Diagnostics* menu and recommendations below.

Diagnostics Menu (d ,RŁ)

The *Diagnostics* menu is located in the *Advanced Features* menu, to access *Diagnostics* menu see *Advanced Features Menu* on page 37.

This menu allows the user to test the functionality of all the meter LEDs, check the meter's software and version information, and erase the DDMC Meter View software installation files from the meter. Press the Enter button to view the settings and the Menu button to exit at any time.

For a description of the diagnostic messages, see *Advanced Features Menu & Display Messages* on page 37.

Determining Software Version

To determine the software version of a meter:

1. Go to the *Diagnostics* menu (d ,RŁ) and press Enter button.
2. Press Up arrow button and scroll to Information menu (InFŁ).
3. Press Enter to access the software number (5FŁ) and version (ŁŁr) information. Write down the information as it is displayed. Continue pressing Enter until all the information is displayed.
4. The meter returns to Run Mode after displaying all the settings.

Reset Meter to Factory Defaults

When the parameters have been changed in a way that is difficult to determine what's happening, it might be better to start the setup process from the factory defaults.

Instructions to load factory defaults:

1. Enter the *Advanced Features* menu. See *Advanced Features Menu* on page 37.
2. Press Up arrow to go to *Diagnostics* (d ,RŁ) menu
3. Press and hold Right arrow for three seconds, press Enter when display flashes rESEŁ.
- Note: If Enter is not pressed within three seconds, the display returns to the *Diagnostics* menu.
4. The meter goes through an initialization sequence (similar as on power-up), and loads the factory default settings.

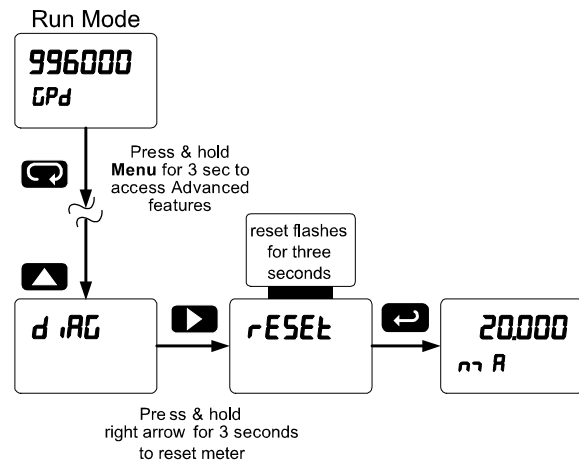

Note: The dual-scale selection for some level applications (d-5ŁRL) is not reset to the single scale factory default. This can be changed using the Setup – Input menu.

Factory Defaults & User Settings

The following table shows the factory setting for most of the programmable parameters on the meter.

Parameter	Display	Default Setting
Input type	Input	4-20 mA
Dual-scale feature	dscale	No (Single scale)
Filter	Filter	70
Bypass	bypass	0.2
Function	Function	Linear
Number of points	nopts	2
Programming	Prog	Scale
Input 1	Input 1	4.000 mA
Display 1	dis 1	4.000
Input 2	Input 2	20.000 mA
Display 2	dis 2	20.000
Decimal point	dddd	3 places
Cutoff value	cutoff	0.000 (disabled)
Display assignment	display	
Display Line 1	line 1	PV: Process variable
Display Line 2	line 2	Eng unit default= mA
Display intensity	display	6
Relay 1 action	Rel 1	Automatic
Relay 1 set point	Set 1	1.000
Relay 1 reset point	rset 1	0.500
Relay 2 action	Rel 2	Automatic
Relay 2 set point	Set 2	2.000
Relay 2 reset point	rset 2	1.500
Relay 3 action	Rel 3	Automatic
Relay 3 set point	Set 3	3.000
Relay 3 reset point	rset 3	2.500
Relay 4 action	Rel 4	Automatic
Relay 4 set point	Set 4	4.000
Relay 4 reset point	rset 4	3.500
Fail-safe relay 1	FLS 1	Off
Fail-safe relay 2	FLS 2	Off
Fail-safe relay 3	FLS 3	Off
Fail-safe relay 4	FLS 4	Off
On delay relay 1	On 1	0.0 sec
Off delay relay 1	OFF 1	0.0 sec
On delay relay 2	On 2	0.0 sec
Off delay relay 2	OFF 2	0.0 sec

Parameter	Display	Default Setting
On delay relay 3	On 3	0.0 sec
Off delay relay 3	OFF 3	0.0 sec
On delay relay 4	On 4	0.0 sec
Off delay relay 4	OFF 4	0.0 sec
Loop break relay 1	loopbrk 1	Ignore
Loop break relay 2	loopbrk 2	Ignore
Loop break relay 3	loopbrk 3	Ignore
Loop break relay 4	loopbrk 4	Ignore
Display 1 analog out	dis 1	4.000
Output 1 value	out 1	4.000 mA
Display 2 analog out	dis 2	20.000
Output 2 value	out 2	20.000 mA
Source analog output	source	Process Variable
Overrange output	orrange	21.000 mA
Underrange output	urrange	3.000 mA
Loop break output	loopbrk	1.000 mA
Maximum output	max	23.000 mA
Minimum output	min	1.000 mA
Slave ID (Address)	slave id	247
Baud rate	baud	9600
Transmit delay	tr delay	50 ms
Parity	parity	Even
Byte-to-byte timeout	byte	010 (0.1 sec)
F1 function key	F1	Reset max & min
F2 function key	F2	Line 1: Max (Hi)
F3 function key	F3	Acknowledge relays
F4 function	F4	Acknowledge relays
Digital input 1	di 1	Menu
Digital input 2	di 2	Right arrow
Digital input 3	di 3	Up arrow
Digital input 4	di 4	Enter
Digital output 1	do 1	Alarm 1
Digital output 2	do 2	Alarm 2
Digital output 3	do 3	Alarm 3
Digital output 4	do 4	Alarm 4
Password 1	passwd 1	000000 (unlocked)
Password 2	passwd 2	000000 (unlocked)
Password 3	passwd 3	000000 (unlocked)

Troubleshooting Tips

This meter is a highly sophisticated instrument with an extensive list of features and capabilities. If the front panel buttons are used to program the meter, it may be a difficult task to keep everything straight. That is why we strongly recommend the use of the free DDMC Meter View software for all programming activities. A cable is provided with the meter for programming with DDMC Meter View software.

If you have programmed the meter with the front panel buttons and it is not working as intended, try re-programming the meter using DDMC Meter View software.

Symptom	Check/Action
No display at all	Check power at power connector
Not able to change setup or programming, L o c k is displayed	Meter is password-protected, enter correct six-digit password to unlock
Meter does not respond to input change	If a <i>Low-Flow Cutoff Value</i> has been programmed, the meter will display zero below that point, regardless of the input – which can appear like the meter is not responding to an input change. Check to make sure the problem is not being caused by an undesired low-flow cutoff value.
Meter displays error message during calibration (E r r o r)	Check: 1. Signal connections 2. Input selected in <i>Setup</i> menu 3. Minimum input span requirements
Meter displays 1. 999999 2. -999999	Check: 1. Input selected in <i>Setup</i> menu 2. Corresponding signal at Signal connector
Display is unstable	Check: 1. Input signal stability and value 2. Display scaling vs. input signal 3. Filter and bypass values (increase)
Display response is too slow	Check filter and bypass values
Display reading is not accurate	Check: 1. Input signal conditioner selected: Linear, square root, etc. 2. Scaling or calibration
Display does not respond to input changes, reading a fixed number	Check: 1. Display assignment, it might be displaying max, min, or set point.
Display alternates between 1. H i and a number 2. L o and a number	Press Menu to exit max/min display readings.
Relay operation is reversed	Check: 1. Fail-safe in <i>Setup</i> menu 2. Wiring of relay contacts
Relay and status LED do not respond to signal	Check: 1. Relay action in <i>Setup</i> menu 2. Set and reset points
Flashing relay status LEDs	Relays in manual control mode or relay interlock switches opened.
Meter not communicating with application programs	Check: 1. Serial adapter and cable 2. Serial settings 3. Meter address and baud rate
If the display locks up or the meter does not respond at all	Cycle the power to reboot the microprocessor.
Other symptoms not described above	Call Technical Support for assistance.

Note: Certain sequences of events can cause unexpected results. To solve these issues, it is best to start fresh from factory defaults and use the manual as a step by step programming guide, rather than a random approach to programming. To reset the meter to factory defaults, see Reset Meter to Factory Defaults on page 44. In addition, for best results, we recommend using the free DDMC Meter View software for all programming needs.



EU Declaration of Conformity

Issued in accordance with ISO/IEC 17050-1:2004.

We,

Precision Digital Corporation
233 South Street
Hopkinton, MA 01748 USA

as the manufacturer, declare under our sole responsibility that the product(s),

Model PD6000 ProVu Series Process Meter

to which this declaration relates, is in conformity with the European Union Directives shown below:

2014/35/EU	Low Voltage Directive
2014/30/EU	EMC Directive
2011/65/EU	RoHS Directive

This conformity is based on compliance with the application of harmonized or applicable technical standards and, when applicable or required, a European Union notified body certification.

Standards:

EN 55022:2003
EN 61000-6-2:2001
EN 61010-1:2001
EN 61326:2006

The standards EN 55022:2003, EN 61000-6-2:2001, EN 61010-1:2001, and EN 61326:2006 are no longer harmonized. The requirements of these standards have been checked against the harmonized standards EN 55022:2010, EN 61000-6-2:2005, EN 61010-1:2010, and EN 61326:2013 and there were no major technical changes affecting the latest technical knowledge for the products listed above.

Product Markings:



Signed for and on behalf of Precision Digital Corporation:



Name: Jeffrey Peters
Company: Precision Digital Corporation
Title: President
Date: 04/20/2016

Document No: DoC PD6000 {042016}

Contact Ametek

Technical Support

Call: (215) 674-1234

Fax: (215) 323-9450

Email: mctpmt.sales@ametek.com

Sales Support / Place Orders

Call: (215) 674-1234

Fax: (215) 323-9450

Email: mctpmt.sales@ametek.com

For the latest version of this manual please visit

www.ametekusg.com

AMETEK

205 Keith Valley Rd • Horsham, PA 19044 USA

Sales/Technical Support Telephone: +1 215-674-1234 • Fax: 215-323-9450

Email: mctpmt.sales@ametek.com



LIM6000DB_G
SFT039 Ver 4.010 & up
9/20