

Model 40

PNEUMATIC INDICATING CONTROLLER





NOTICE

These instructions apply to various controllers and their operation, installation and maintenance. Information on variations not covered by these instructions should be requested from AMETEK, PMT PRODUCTS. The customer should be aware that an alternative means of protection of a monitored process may be necessary should this instrument fail.

RETURN OF INSTRUMENT

If it becomes necessary to return the instrument, it should be sent directly to AMETEK, PMT PRODUCTS 205 Keith Valley Road, Horsham, PA 19044. Contact the factory as follows to obtain a Return Authorization number (RA#) **before** returning the unit.

Tel: 215-674-1234, E-mail: mctpmt.sales@ametek.com

REPLACEMENT PARTS

Replacement parts should be ordered through your local AMETEK Representative/Distributor or from AMETEK, PMT PRODUCTS as noted below. Include the instrument model number located on the inside of the door.

Tel: 215-674-1234, E-mail: mctpmt.sales@ametek.com



TABLE OF CONTENTS

INSTALLATION

Mounting of Case	1
Output Connection	1
Supply Connection	1
Process Piping	2
Process Connection	3
Elevation Adjustments.	3

PRINCIPLE OF OPERATION

Low Bleed Relay	3
Set-Point	3
Proportional Controller	3
Differential Gap Controller.	3
Controller Diagram	4
Proportional+ Reset Controller	4
Proportional + Reset + Rate Controller.	5

SELECTION OF CONTROL ACTION

Reversing Action.	5
Controller Diagram	6

TUNING CONTROLLER TO PROCESS

Proportional Controller	7
Manual Reset	7
Differential Gap Controller.	7
Multi-Mode Controllers	7
Tuning Proportional + Reset Controller.	7
Tuning Proportional + Reset + Rate Controller.	8

MANUAL CONTROL AND START UP

Proportional Controller	8
Proportional+ Reset Controller	9
Proportional + Reset + Rate Controller.	9

TROUBLE SHOOTING

Process	9
Control Valve	9
Instrument.	10
Low Output Problems.	10
High Output Problems	10
Output Cycling Problems	10
Trouble Shooting Table	10

MAINTENANCE

General	11
Relay	11
Proportional Controller	12
Proportional+ Reset Controller	12
Proportional + Reset + Rate Controller.	13



User Manual

Measuring Element	
Calibration And Tracking Instructions for All Elements	14
Bourdon Pressure Elements	15
Metal Diaphragm Pressure Elements	16
Slack Diaphragm Actuated Pressure Elements	16
Slack Diaphragm Actuated D/P, Vacuum & Compound Elements	17
High Static Pressure Actuated D/P Element	18
Chassis	19
Door	19
Filter Fittings	19

SPECIAL CONTROLLERS

Two Position By-Pass (Auto/Manual) Controller	20
---	----

REPLACEMENT PARTS LISTS

Bourdon Tube Pressure Elements	21
Metal Diaphragm Elements	23
Slack Diaphragm Elements	25
High Static D/P Elements	26
Door & Case Assemblies	27
Chassis Assemblies	28
Relay	30
Filter Fittings	31
Feedback Assemblies	32
Replacement Parts Kits	35
Output Gauge Assembly Option	36
Two Position By-Pass (Auto/Manual) Switch/Indicator	36
External Reset Feedback Option	36
Mounting Brackets	37
Dripwell Filter Regulator	37
High Static D/P Controller (Outline Dwg.)	38
Standard Controller (Outline Dwg.)	39
Slack Diaphragm Controller (Outline Dwg.)	39



Figure 1

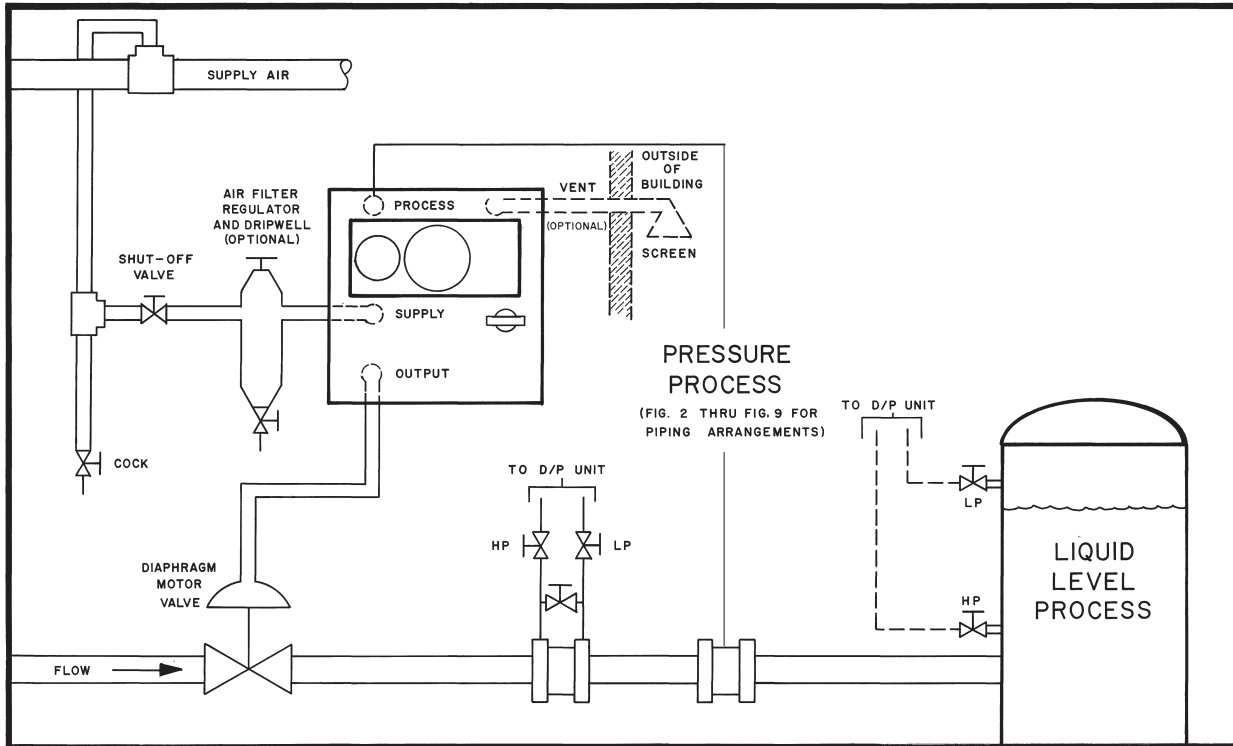

INSTALLATION

MOUNTING OF CASE

The instrument should be mounted vertically on a panel, wall, pipe, or valve where it will be reasonably free from vibration, shock and large fluctuations of temperature. Brackets for panel and surface mounting are standard. Wall, pipe and valve mounting brackets are optional (see outline drawing for mounting dimensions).

OUTPUT CONNECTION (See Fig. 1)

A porous metal output filter is supplied in the output connection of all multi-mode controllers. If the output of the controller is fed directly to a valve top, the filter may be discarded. If the output is fed to a valve positioner or to a small valve, the filter should be left in the output as it contributes to control stability at proportional bands greater than 100%. For operation at narrower bands and where speed of response is important the filter may be removed.

SUPPLY CONNECTION (See Fig. 1)

BEFORE APPLYING SUPPLY AIR REFER TO PRESSURE LIMIT LABEL ATTACHED TO RELAY.

Instrument requires clean, dry, oil-free air. Each controller should be supplied through a standard instrument dripwell-filter and a reducing regulator with automatic relief valve. The supply pressure must be regulated at:

- 20 psi (140 kPa) for 15 psi (100 kPa) output
- 35 psi (240 kPa) for 27 psi (186 kPa) output
- 35 psi (240 kPa) for 30 psi (200 kPa) output
- 65 psi (450 kPa) for 60 psi (400 kPa) output

Avoid getting dirt, pipe scale, burrs, chips, oil, pipe compound or any foreign matter into supply air lines as these may render instrument inoperative.

Natural gas may be used to operate the controller if instrument case is sealed and a 1/2" pipe vent connection is tapped in the back. Vent piping to outside air should open downward outside of the building to protect from rain and be screened to avoid entry of insects which may plug vent pipe. Any back pressure from vent obstruction will cause instrument to read low and control high when door is closed. Long or crooked vent lines should be of larger size.

PROCESS PIPING

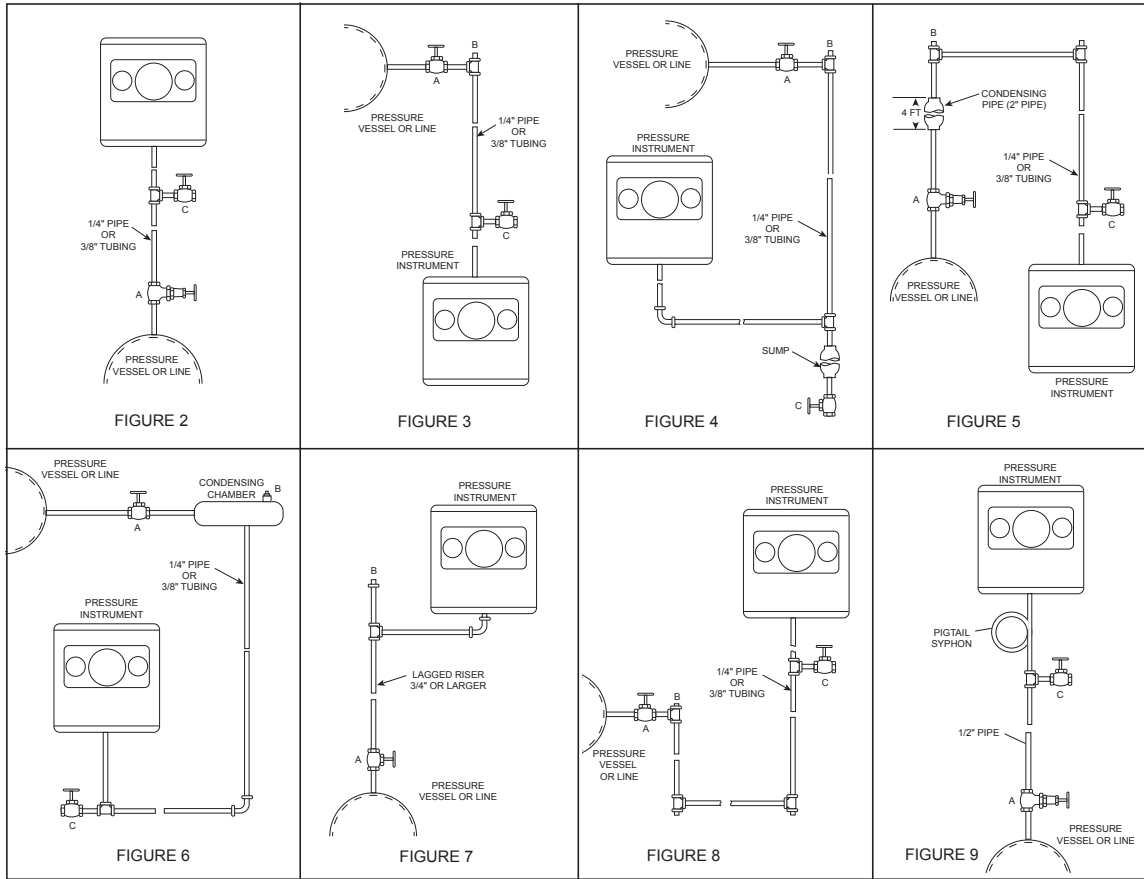

PROCESS	COMMENT	FIGURE
Dry Gas	Valve "C" is not needed	Fig. 2 or Fig. 3
Wet Gas	Gate Valve and ½" or larger line tap	Fig. 2
Vapor (steam)	Instrument below line	Fig. 3 or Fig. 6
Vapor (steam)	Instrument above line	Fig. 2
Vapor (steam)	Rapid pressure fluctuations and low condensing temperature of vapor	Fig. 6
Vapor (steam)	Temperature exceeds 300°F (149°C)	Fig. 9
Vapor (steam)	Elevation exceeds 25 ft. H ₂ O (75kPa) Non-condensable vapor & high vapor pressure (SEE ELEVATION ADJUSTMENT).	Fig. 7
Liquid	Connect at side of line to avoid gas or vapor collecting at top of line or sediment at bottom.	Fig. 3
Liquid	Prevent gas or vapor entering riser (instrument should not be higher than 25 ft. (7, 6m) above line connection – SEE ELEVATION ADJUSTMENT).	Fig. 8



PROCESS CONNECTION (See Fig. 2 thru Fig. 9)

BEFORE APPLYING PROCESS REFER TO PRESSURE LIMIT LABEL ATTACHED TO INSTRUMENT.

Pressure connection is ¼" NPT (std).

For corrosive fluids which would attack the process element it is desirable to use a chemical seal which isolates the measuring element from the corrosive medium. If seal is installed at different elevation from instrument, correction must be made. SEE ELEVATION ADJUSTMENT.

ELEVATION ADJUSTMENT

INSTRUMENT SHOULD BE FREE OF TRAPPED AIR OR VAPOR BEFORE MAKING ELEVATION ADJUSTMENT

When a correction is necessary the process and setting pointers must be moved upscale when the instrument is above the process line and downscale when below until it reads line pressure instead of pressure at instrument level. The correct amount is 1 PSI for 27.7" H₂O (6,9kPa) and is proportional to the specific gravity of other liquids. For remote chemical seal attachment (S.P. of filling fluid is 0.9). The correction is 1 PSI for 30.8" of fill fluid.

PRINCIPLE OF OPERATION

LOW BLEED RELAY (Fig. 10)

The low bleed relay is in equilibrium (neither feeding nor exhausting air) as long as the process is not changing. At equilibrium the force exerted by the nozzle diaphragm equals the force exerted by the output diaphragm. A change in the process causes a change in the flapper nozzle gap, thus producing a change of nozzle back pressure which changes the force exerted by the diaphragm. The force exerted by the nozzle diaphragm is not equal to the force exerted by the output diaphragm, causing the valve stem to move to a new position either opening the inlet port allowing supply air to enter the output or opening the exhaust port exhausting output air. Either of these changes continue until the force developed by the output diaphragm balances the force of the nozzle diaphragm and equilibrium is restored.

SET POINT (Fig. 10)

Control point setting is accomplished by turning the set point knob to swing the entire outer movement up or down around pivot S. The setting motion is fed to the indicating movement by link EF and is shown by set pointer (red).

PROPORTIONAL CONTROLLER

(Fig. 10 – shown in reverse action)

With a decrease in process pressure the following occurs:

1. Process pointer (Black) rotates counterclockwise (ccw) from a downward motion of GH.
2. Lever BCD rotates clockwise (cw) from a downward motion of AB.
3. Arbor PP rotates ccw causing flapper to restrict nozzle flow.
4. Supply pressure feeding thru restrictor expands nozzle diaphragm.
5. Inlet port opens and exhaust port closes.
6. Output pressure on output gauge increases.
7. Feedback capsule expands moving link JL to the left.
8. Proportional link NM pivoting about M causes link JK to move upward.
9. Lever KC rotates cw about P causing lever BCD to rotate ccw about B producing flapper motion off-setting input motion.
10. Equilibrium is reached with the change in output proportional to the change in input.

Proportionality factor or band adjustment is determined by the angle LNM producing the necessary amount of feedback.

DIFFERENTIAL GAP CONTROLLER (Fig. 10)

With M in line with JK negative feedback is reduced to zero and essentially on-off action results. If proportional dial is rotated to other quadrant, (position M') feedback motion becomes positive adding to input from "A" with on and off points separated by the amount of feedback motion.



PROPORTIONAL + RESET CONTROLLER (Fig. 10)

The function of the reset action is to eliminate the proportional offset between the measuring process and the setpoint and to accomplish this in the shortest possible time without creating instability in the proportional control action. The reset feedback is similar in appearance to the rate feedback except that the output pressure is also applied to the inside of the capsule. When the reset valve is shut, the reset action is eliminated

and the controller operates as a proportional instrument. When the reset valve is set to the proper restriction the reset restriction and reset chamber form a resistance-capacity network which at first delays the balance across the capsule but in a definite time period produces equilibrium and restores the process to the set point.

In Fig. 10, with the nozzle and proportional dial in the positions shown, the proportional and reset controller will be reverse acting.

Figure 10

Controller Diagram

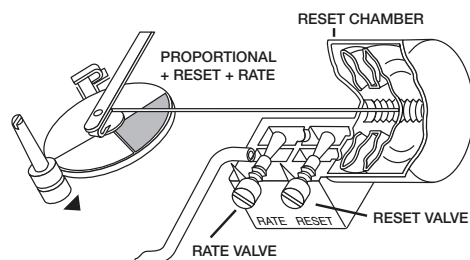
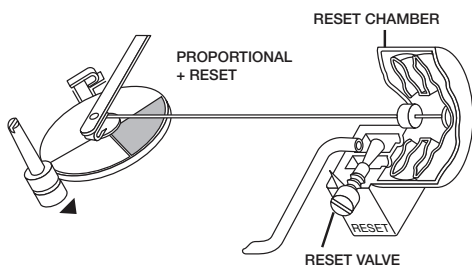
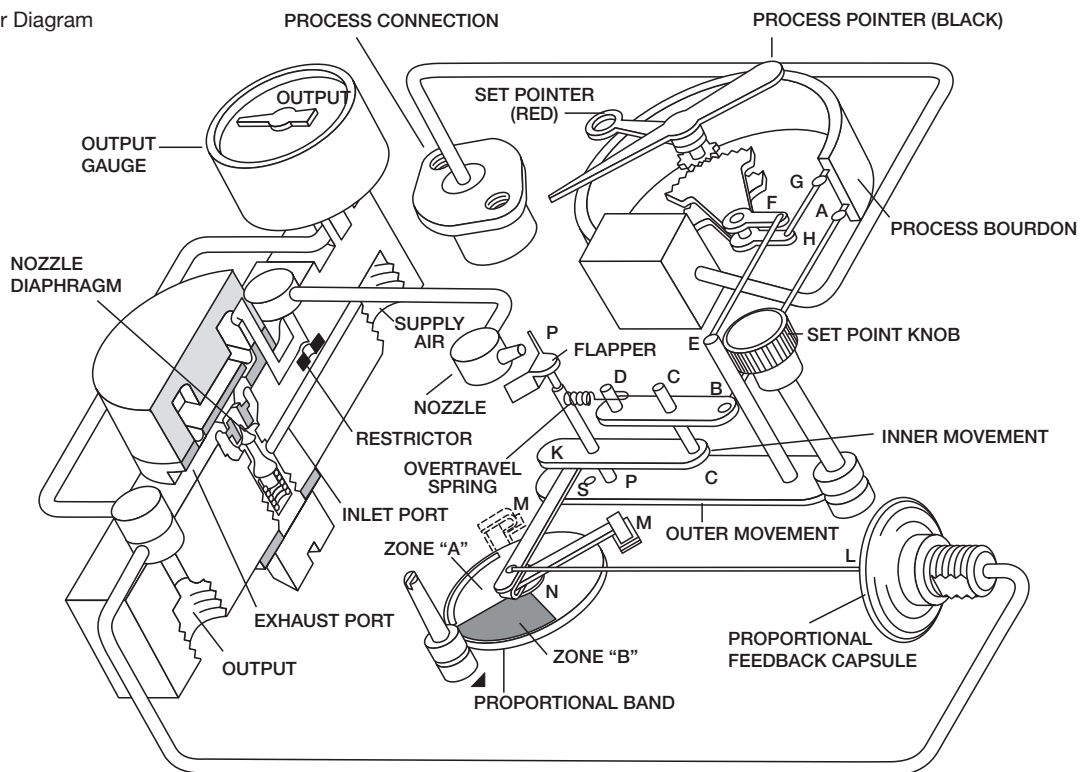





PROPORTIONAL + RESET + RATE CONTROLLER (Fig. 10)

The function of the three mode controller (proportional, reset and rate) is to eliminate off set, increase stability and reduce stabilization time. With the rate and reset valve in series (reset restriction following rate restriction) over-shooting on start-up and instability due to too much resetting action are prevented because rate time will never exceed reset time.

With the reset valve closed the instrument acts as a two mode controller (proportional + rate) as described in the previous section. As the reset valve is partially opened, output air is metered into the air chamber outside of the capsule causing the feedback to respond to the error between the process and set point.

In Fig. 10, with the nozzle and proportional dial in the positions shown, the proportional + reset + rate controller will be reverse acting.

SELECTION OF CONTROL ACTION

IF AN INCREASE IN PRESSURE MUST	AND THE ACTION OF THE VALVE IS	THEN THE ACTION OF THE CONTROLLER MUST BE	AND THE NOZZLE POSITION MUST BE	AND FOR THE FOLLOWING CONTROLLERS THE GREEN POINTER IS IN ZONE	
				PROPORTIONAL	PROP. + RESET OR PROP. + RESET + RATE OR DIFFERENTIAL GAP
CLOSE VALVE	AIR TO CLOSE	DIRECT		A-WHITE	B-BLACK
OPEN VALVE	AIR TO OPEN				
CLOSE VALVE	AIR TO OPEN	REVERSE		B-BLACK	A-WHITE
OPEN VALVE	AIR TO CLOSE				

Determine whether a rise in pressure should open or close the valve. Position the nozzle as shown in table and rotate the proportional dial so that the green pointer is in the "A" or "B" sector for a given controller.

REVERSING ACTION

Supply air to controller is necessary for this operation. Loosen nozzle screw one half turn and rotate nozzle until it is pointing squarely at flapper blade. Tighten screw. Turn proportional dial to appropriate zone.

If output gauge does not show full supply pressure when flapper is held against nozzle, readjust nozzle.

NOTE: When changing the Control Action, make sure the alignment of the nozzle and flapper are parallel to each other. This helps ensure proper operation. Pinching the flapper against the nozzle should make output pressure go to max pressure (supply pressure).

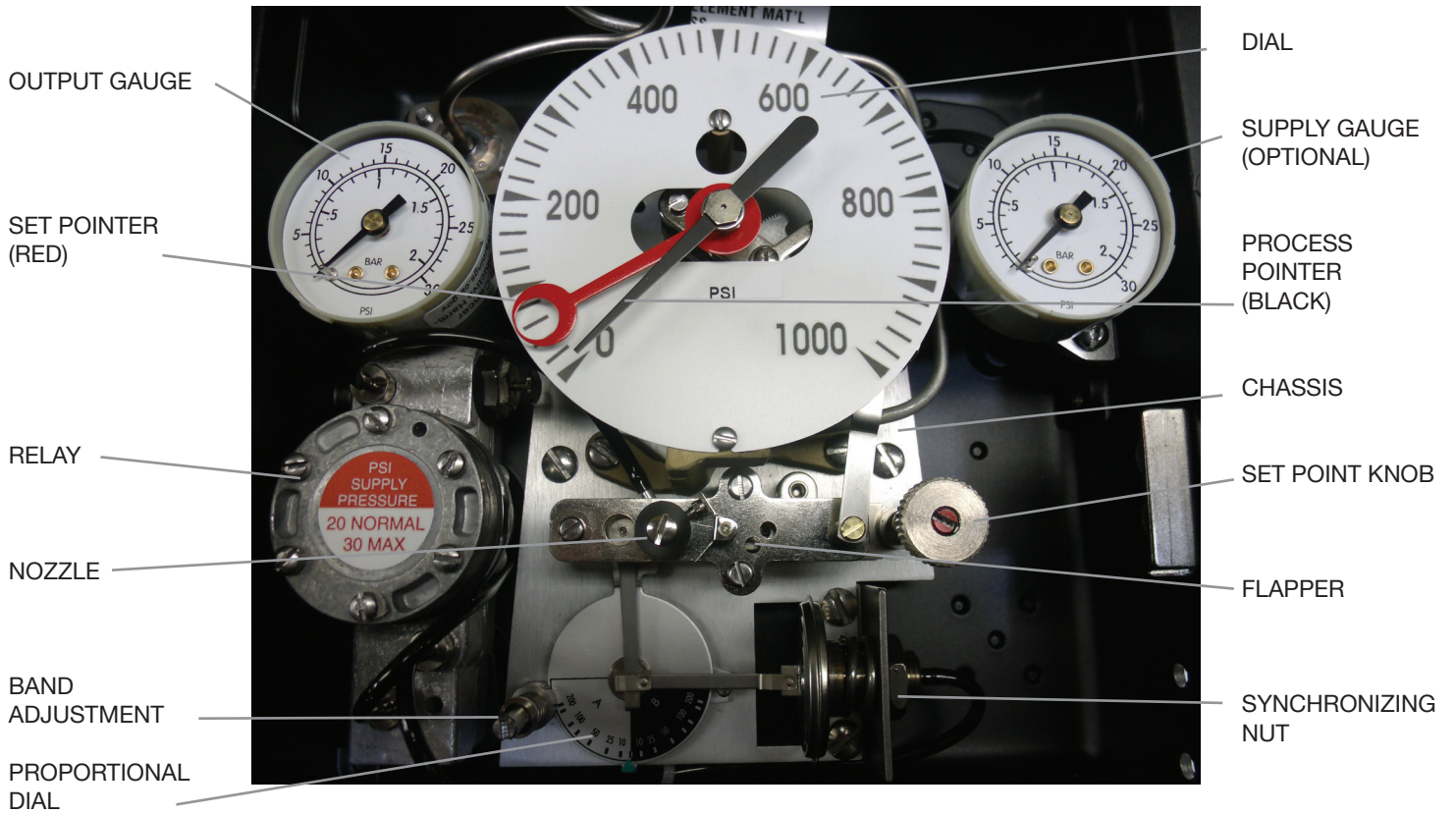

Figure 11



TUNING CONTROLLER TO PROCESS

PROPORTIONAL CONTROLLER

Start up – turn on air and drain dripwell through its drain valve. Adjust regulator to required supply pressure. *

Adjust set pointer to desired operating point by turning set point knob.

Watch control operation. If controlled pressure cycles, increase proportional band in steps until stable. Then increase by half of setting for a margin of stability. If control seems sluggish and wandering, reduce proportional band setting in steps until measurement is jittery or slightly cyclic. Increase proportional band in steps until stable then increase by half of setting for a margin of stability. Increasing proportional band until just stable is not recommended as instability and cycling may result under slightly changed operating conditions.

When continued adjustment does not bring process into control it is best to look for erratic behavior of process, control valve, or controller. See section on TROUBLE SHOOTING. By controlling process manually it will become apparent whether difficulties are with control system (instrument and valve) or with process. See section on MANUAL CONTROL.

MANUAL RESET

After the controller is in operation, the black indicating pointer may not be over the red setting pointer, since factory adjustment is based on pointers coinciding at mid-span output.** To manually reset the pointers, note position of black pointer then turn setting knob to move red pointer up to that position. Allow measurement to settle. Turn synchronization nut on the proportional feedback (Fig. 11) to bring black pointer into matching position. The pointers will only match for the load at which the adjustment was made. Where load is quite variable, synchronization is usually omitted.

DIFFERENTIAL GAP CONTROLLER

Turn on air and drain dripwell through its drain valve. Adjust regulator to required supply pressure.* Set red pointer to center of desired differential gap. Turn band adjustment to desired band width on proportional dial. Note extreme high and low values which process

reaches. Adjust band to widen or narrow as necessary. Adjust red pointer up or down until differential gap is at desired level. Red pointer may be anywhere in the band. To set pointer for top, bottom or center of band (as desired) hold red pointer hub with 0.25" ignition wrench and turn pointer, pushing it near its center to avoid bending it.

* 20 psi (140 kPa) for 15 psi (100 kPa) output
35 psi (240 kPa) for 30 psi (200 kPa) output
65 psi (450 kPa) for 60 psi (400 kPa) output

**9 psi (60 kPa) for 3-15 psi (20-100 kPa) controllers
18 psi (125 kPa) for 6-30 psi (40-200 kPa) controllers
36 psi (250 kPa) for 12-60 psi (80-400 kPa) controllers

MULTI-MODE CONTROLLER

The output of multi-mode controllers is the result of several actions acting simultaneously. Since at any moment the control effects may be additive or may be opposed, it may be difficult to analyze process changes. In difficult applications or in troublesome situations it is helpful to record the measurement and the output pressure. When recording instruments are not available, the value of the controlled variable and output pressure may be read periodically and plotted.

When continued adjustment per these instructions fails to bring process into control it is best to look for erratic behavior of the process, control valve or controller. See section on TROUBLE SHOOTING. By controlling the process manually it will become apparent whether difficulties are with the control system (instrument and valve) or with the process. See section on MANUAL CONTROL. Manual start up may also be used if automatic start up causes excessive overshooting.

TUNING PROPORTIONAL + RESET CONTROLLER

Note action of controller (reverse or direct). Set red pointer 30% above black pointer if direct, 30% below black pointer if reverse acting. Open reset valve fully by turning clockwise to stop. Hold for a few seconds, then set reset dial between 0.2 and 0.5 minutes per repeat. Set proportional band at 50% (green pointer). Turn on supply air. Output of controller should remain zero. Drain dripwell through its drain valve. Adjust regulator to required supply pressure.* Set red pointer to coincide with black pointer. Output



will slowly increase. When output reaches mid-span**, quickly turn reset dial counterclockwise to stop. Output should hold at mid-span. Instrument is now operating as a proportional controller. Set red pointer to desired value.

Watch control operation. If controlled variable cycles, widen proportional band in steps until stable. Note period of oscillation of controlled variable when red pointer is moved a small amount up or down. The period is the time between two maximum or minimum peaks. If controlled variable is sluggish and wandering, reduce proportional band setting in steps, until controlled variable is jittery or cycles a bit. Note period of cycling in minutes.

Increase proportional band to 2-2 1/2 times the band setting which was obtained by preceding method. Reset valve may be set for the same time as the period of cycling.

The above settings are suggested values and may be varied depending on the specific requirements of the process. For more stability, widen proportional band and/or increase the reset time. If process is too sluggish, reduce proportional band and/or reset time. Note that a little less than optimum reset time may cause cycling while even three to four times optimum may make little difference. This is particularly true for processes with slow load changes.

After process has stabilized, the red and black pointer may not be coincident. To synchronize, hold hex hub of red pointer with 0.25" wrench and turn pointer, pushing it near its center to avoid bending it.

If the process levels off too soon and approaches the set point in steps, the rate action is excessive. If there is an overshoot, more rate action is needed. The final setting should be a compromise between start-up and running performance.

TUNING PROPORTIONAL + RESET + RATE CONTROLLER

With the rate valve fully open, proceed as described in TUNING PROPORTIONAL CONTROLLERS + RESET.

Now increase the rate time in steps watching the process become more stable and finally unstable again. Return to a value giving stability. In case

of uncertainty, try about 1/8 of the cycle time noted above.

Repeat adjustment of proportional band, which now may permit a somewhat narrower setting, and then increase the rate time. Watch the process long enough to be sure the adjustments have sufficient margin of safety for normal process upsets.

If the rate time has to be kept close to zero, either the process does not need rate action or the process or control system is not in condition to tolerate rate action.

After process has stabilized, the red and black pointer may not be coincident. To synchronize, hold hex hub of red pointer with 0.25" wrench and turn pointer, pushing it near its center to avoid bending it.

* 20 psi (140 kPa) for 15 psi (100 kPa) output
35 psi (240 kPa) for 30 psi (200 kPa) output
65 psi (450 kPa) for 60 psi (400 kPa) output

** 9 psi (60 kPa) for 3-15 psi (20-100 kPa) controllers
18 psi (125 kPa) for 6-30 psi (40-200 kPa) controllers
36 psi (250 kPa) for 12-60 psi (80-400 kPa) controllers

MANUAL CONTROL AND START UP

Some processes must be brought up to control point manually as the first overshoot on start up may be well beyond permissible limits. In addition, manual operation of process provides a means of diagnosing difficulties in the process which might ordinarily be attributed to the controller.

FOR PROPORTIONAL CONTROLLERS

To start up manually Note controller action (direct or reverse). If direct acting, set red pointer well below black pointer and desired value. If reverse acting, set red pointer well above black pointer and desired value. This will cause controller to put out full output pressure. Adjust diaphragm control valve opening by adjusting supply regulator. When process is under control at desired value, note output pressure.

To switch to automatic Move red pointer back toward desired value until output pressure just drops. Restore supply pressure. To correct valve adjust red pointer to be sure output pressure is brought to exact value noted during manual control.



FOR PROPORTIONAL + RESET CONTROLLERS

To start up manually Open reset valve fully by turning reset knob clockwise to stop. Note controller action (direct or reverse). If direct acting, set red pointer well below black pointer and desired value. If reverse acting set red pointer well above black pointer and desired value. This will cause controller to put out full output pressure. Adjust diaphragm control valve opening by adjusting supply regulator. When process is under control, note output pressure.

To switch to automatic Shut reset valve by turning reset knob counterclockwise to stop. Move red pointer back toward desired value until output pressure just drops. Restore supply pressure. To correct valve, adjust red pointer to be sure output pressure is brought to exact value noted during manual control.

Tuning procedure for proportional + reset controllers may now be followed. If instrument is already tuned, reset valve may be set at previously determined value.

FOR PROPORTIONAL + RESET + RATE CONTROLLERS

To start up manually Open reset valve fully by turning reset knob clockwise to stop. Open rate valve fully by turning rate knob clockwise to stop. Note controller action (direct or reverse). If direct acting, set red pointer well below black pointer and desired value. If reverse acting, set red pointer well above black pointer and desired value. This will cause controller to put out full output pressure. Adjust diaphragm control valve opening by adjusting supply regulator. When process is under control, note output pressure.

To switch to automatic Shut reset valve by turning reset knob counterclockwise to stop. Move red pointer back toward desired value until output pressure just drops. Restore supply pressure. To correct valve, adjust red pointer to be sure output pressure is brought to exact value noted during manual control. Tuning procedure for proportional + reset + rate controllers may now be followed. If instrument is already tuned, reset and rate valves may be set to previously determined values.

TROUBLE SHOOTING

PROCESS

When it is indicated that the difficulties are in the process (by manual control method or other diagnosis), a systematic check procedure is suggested. Following is a check list of some common process difficulties.

1. In a pressure controlled process the pressure tap must be in a representative location and should not tend to become air bound or water logged as these actions will tend to give erratic and erroneous measurement which will in turn cause erratic control.
2. The control fluid should reach the control valve in sufficient quantity to maintain control. The controlled media should be free of debris which could foul the control valve.
3. Steam traps must operate efficiently, not permitting back-up of condensate. If system is steam fed and operating below 212°F (100°C) the condensate system must be designed for vacuum service. Violent cycling will result when traps are not designed for vacuum service.
4. If process has a heat exchanger, the heat exchange surface must be adequate. It must not become air bound or flooded. Foreign matter tending to accumulate should be cleaned periodically to prevent excessive transfer lag.

CONTROL VALVE

1. Valve must be sized correctly. It should be large enough to maintain the process for most load conditions. If it operates near the fully open position continually, it is probably undersize and does not have sufficient controllability. If it operates near the closed position, it is probably oversize.
2. When large pressure fluctuations occur in control fluid, the valve should be of balanced construction or utilize a positioner, to prevent movement of the valve from this source.
3. Erratic valve action can occur from sticking of the stem due to corrosion. Proper material selection will eliminate this problem.



INSTRUMENT

Due to multiplicity of symptoms and causes of trouble, a tabular arrangement for trouble shooting in the instrument will facilitate checking.

LOW OUTPUT PROBLEMS

Check leakage in the nozzle line connections at the nozzle and at the relay. If satisfactory, remove flexible tubing from relay and close hole with finger. If pressure increases the problem is in the nozzle assembly. Remove nozzle assembly. Clean or replace as necessary. If pressure does not increase, the problem is in the relay. SEE MAINTENANCE-RELAY.

HIGH OUTPUT PROBLEMS

Move flapper away from nozzle. If output decreases, check friction in shaft, linkage and overtravel spring. If output does not decrease remove nozzle's flexible tubing at relay. If output decreased, the problem is in the nozzle assembly. Remove nozzle assembly and clean or replace as necessary. If output pressure does not decrease when the nozzle line at the relay is open, the problem is in the relay. SEE MAINTENANCE-RELAY.

OUTPUT CYLCING PROBLEMS

This difficulty will manifest itself by the appearance of process cycling when there had been none before. Before proceeding with any other checks, increase the proportional band setting to determine if this stabilizes the process. If it does, go through the TUNING PROCEDURE. If widening the band does not help, the feedback may be inoperative.

Set the proportional band at approximately 5%. Rapidly change set point around black pointer and observe output motion of the feedback assembly. A clogged tube or broken feedback will show no output motion. See MAINTENANCE PARTS LIST.

A rate feedback assembly which produces no output motion may have a clogged rate valve. To remove and clean the rate valve see MAINTENANCE.

A reset or reset + rate feedback assembly may have a leak in the reset valve which would equalize the pressure between the reset chamber (outside capsule) and the inside of the capsule immobilizing the feedback. To remove and clean the reset valve see MAINTENANCE.

TROUBLE SHOOTING TABLE

TROUBLE	COMMON CAUSES
No measurement, no movement of black pointer.	Stop valve shut, connection clogged, element broken or overranged.
Reads High	Not adjusted for liquid head, element overranged.
Reads Low	Air or vapor trapped in liquid leg, leak in connection line.
Erratic	Linkage sticking, instrument vapor lock or liquid seal in connection.

TROUBLE	COMMON CAUSES	
	Proportional Control	Proportional + Reset Control Proportional + Reset + Rate Control
No supply pressure	Air supply valve shut, line frozen, regulator not set.	
Low supply pressure	Regulator not set properly. Filters clogged.	
No output pressure Low output pressure	Low supply pressure, wrong red pointer setting, dirt in orifice, loose connection in nozzle line, flapper bent or not seating, relay diaphragm broken.	
Output pressure remains high	Wrong red pointer setting, nozzle clogged, orifice assembly loose, flapper jammed closing nozzle.	
Process cycling	Proportional band too narrow, friction in valve or controller, valve oversize.	Reset + rate valves closed or clogged. Proportional band too narrow. Reset rate too fast, friction in valve or controller, friction in reset unit gland, valve oversize. Rate time too low.
Process wanders	Proportional band too wide, valve undersize.	Proportional band too wide, reset rate too slow, valve undersize
Process approaches control in steps.		Rate time too high.
Black pointer away from red pointer.	Normal offset due to load change. Not synchronized with synchronizing nut.	Red pointer misadjusted.



MAINTENANCE

GENERAL

Drain dripwell as required to prevent water filling dripwell and entering instrument.

At regular inspection intervals:

Push nozzle orifice cleaner button in the side of the relay.

Verify process pointer calibration, as process conditions may cause overranging.

Check connections inside and outside instrument and mounting bolts for tightness, especially under vibration conditions.

RELAY (Fig. 12)

Remove from instrument – disconnect supply and output piping. Remove flexible tubing from nozzle connection and feedback connection (when relay has supply gauge option, remove flexible tubing from output gauge connection). Remove four mounting screws on back of case.

Servicing

Should the exhaust or inlet port become fouled with dirt, there will be an audible leak during control. To determine which seat requires

attention, move control point to obtain full output. If leak is audible, exhaust port requires attention. If there is no leak, move control point to obtain zero output. If relay leaks, inlet port requires attention.

The inlet port can be serviced by removing the cap nut at back of instrument. Do not lose the small spring in the cap. The valve stem can be removed and cleaned in solvent. The inlet port can be cleaned with a cotton swab dipped in solvent. The exhaust port seat can be serviced by removing the six-mounting screws. Separating the diaphragm assembly from the relay block may require some force, due to adhesion between the rubber and metal. (Do not damage the rubber diaphragm). Exhaust port can be cleaned with a cotton swab dipped in solvent.

Push-Button Orifice

Remove from the relay block for cleaning using 0.50" open end wrench. Accumulations of grease, dirt, and oil may be removed by soaking in a suitable solvent. When reinstalling, tighten just enough to insure no leakage around metal seat at tip end.

When the relay is reassembled to the instrument, check by opening and closing the nozzle manually. Output should go to full supply value and to zero.

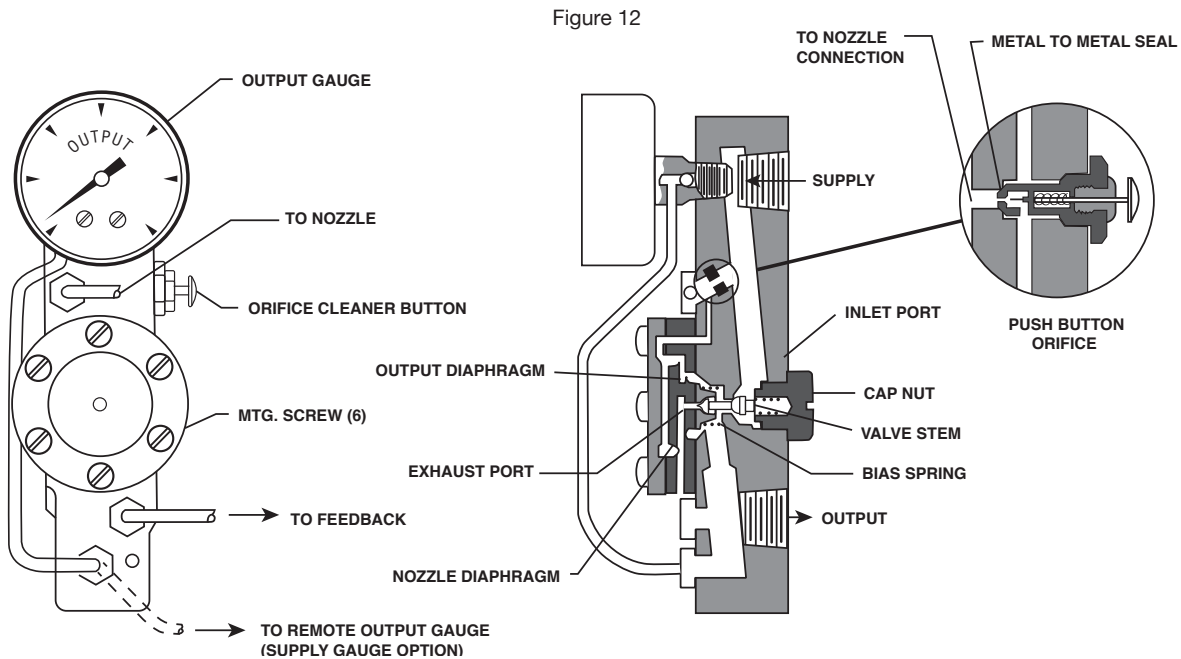



PROPORTIONAL CONTROLLER

To replace feedback – unhook feedback link at proportional band dial. Remove feedback line from relay. Remove synchronizing nut. Replace in reverse order. See ALIGNMENT for synchronizing nut adjustment.

Alignment – with all components assembled and supply air on, proceed as follows:

1. Set proportional band at 10% (2% for 1-15% instrument)
2. Move red pointer with setting knob until output is at mid-span.
3. Turn proportional band to maximum setting. Output pressure should not change more than 10% of output span.
4. Adjust synchronizing nut to obtain mid-span output.
5. Repeat steps 1 thru 4 until output does not vary more than 10% of output span when the proportional band changes.
6. If red pointer does not coincide with black pointer at mid-span output, hold red pointer hub with 0.25" wrench and turn red pointer until it coincides. Caution: Apply torque near hub to avoid bending pointer.

PROPORTIONAL + RESET CONTROLLER (Fig. 14)

To replace feedback – unhook link at proportional band dial. Remove feedback line from relay. Remove two reset block mounting screws. Replace in reverse order. See ALIGNMENT for pointer adjustment.

To replace Valve and Filter – loosen two valve screws (3 turns without removing). Pull up and rotate clockwise until tabs on valve are clear of the screw heads. Remove and replace in the reverse order.

To clean Valve and Filter – remove valve pin by disengaging tension spring from slotted end of pin. Clean seat and pin with suitable solvent. To remove filter, first remove bottom "O" ring. (Do not cut "O" ring on tension spring). Remove filter and clean with solvent.

Alignment – with all components assembled and supply air on, proceed as follows:

1. Set proportional band at 10%.
2. Open reset valve by turning fully clockwise on stop.
3. Set red pointer for full output.
4. Reduce supply pressure until mid-span output is obtained.
5. Shut reset valve by turning full counterclockwise (reset chamber now has mid-span output pressure trapped inside and controller will act like a proportional controller).
6. Restore supply pressure to correct pressure.
7. Move red pointer with setting knob until output pressure is at mid-span.
8. Turn proportional band to maximum setting. Output pressure should not change more than 10% of output span.
9. To obtain mid-span output pressure, loosen locking nuts and move adjusting link to the left or right. Tighten locking nuts.
10. Return band to 10%.
11. Repeat steps 7 thru 10 until output does not vary more than 10% of output span when the proportional band changes.
12. If red pointer does not coincide with black pointer at mid-span output, hold red pointer hub with 0.25" wrench and turn red pointer until it coincides (apply torque near hub to avoid bending pointer.)

Figure 13

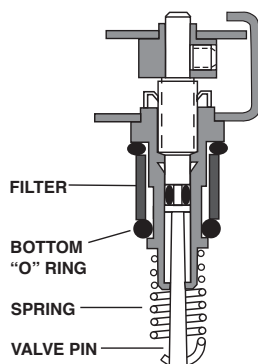
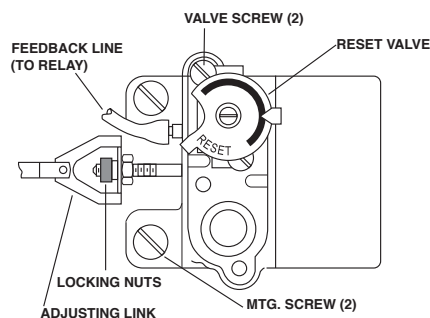

Figure 14





PROPORTIONAL + RESET + RATE CONTROLLER (Fig. 15)

Figure 15

To replace – same as Proportional + Reset Controller.

To replace valve and filter – same as Proportional + Reset Controller.

To clean valve and filter – same as Proportional + Reset Controller.

Alignment – with all components assembled into instrument and supply air on, proceed as follows:

1. Set proportional band at 10%.
2. Open reset valve by turning fully clockwise to stop.
3. Open rate valve by turning fully clockwise to stop.
4. Set red pointer for full output.
5. Reduce supply pressure until mid-span output is obtained.
6. Shut reset valve by turning full counterclockwise (reset chamber now has mid-span output pressure trapped inside and controller will act like a proportional controller).
7. Restore supply pressure to correct pressure.
8. Move red pointer with setting knob until output pressure is at mid-span.
9. Turn proportional band to maximum setting. Output pressure should not change more than 10% of output span.
10. To obtain mid-span output pressure, loosen locking nuts and move adjusting link to the left or right. Tighten locking nuts.
11. Return band to 10%.
12. Repeat steps 8 thru 11 until output does not vary more than 10% of output span when the proportional band changes.
13. If red pointer does not coincide with black pointer at mid-span output, hold red pointer hub with 0.25" wrench and turn red pointer until it coincides (apply torque near hub to avoid bending pointer).

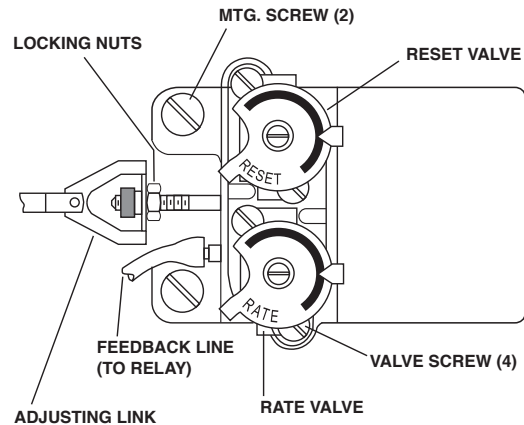



MEASURING ELEMENT

All bourdon tube and metal diaphragm elements are interchangeable.

CALIBRATION AND TRACKING

INSTRUCTIONS FOR ALL ELEMENTS

All measuring elements are calibrated using the same adjustments on the indicating movement. To make these adjustments, the dial must be removed. The dial can be removed without removing the pointers, by aligning the red and black pointers with one another by using the set knob, loosening the two dial screws, and manipulating the elliptical center hole over the pointers.

Calibration of Element is Made as Follows (Fig. 16):

1. Select three pressures at or near; the lower end, the center and the upper end of the dial range. For future reference, these will be known as values P_o , P_c and P_u .
2. Disconnect the control link (closest to chassis) at its upper end. Spring the retainer clip open just enough to disengage the ball from bearing hole.
3. Apply P_o (lower end of range) to the element and note black pointer reading. If it does not read correctly, hold the hex hub of the pointer with 0.25" wrench and turn pointer to proper value. **CAUTION:** Apply torque near center of pointer to avoid bending it.
4. Apply P_u (upper value of scale) to element. Note pointer reading. If pointer reads too high, dimension C must be increased. If the pointer reads too low, dimension C must be decreased. Remove dial and make adjustments as follows:
 - a. To increase C: loosen lock screw $\frac{1}{4}$ turn and turn range adjust hex forward. For each percent of error, hex should be turned about $\frac{1}{4}$ turn. Make proper adjustment. Tighten lock screw.
 - b. To decrease C: loosen lock screw $\frac{1}{4}$ turn and turn range adjust hex back $\frac{1}{4}$ turn for each percent of error. Tighten lock screw.
5. Replace dial, and apply P_o . Reset black pointer to proper reading, apply P_u and note reading, apply P_u and note reading. Make adjustments as described in 4 above. Continue adjusting and testing as per 4 and 5 until pointer reads correctly at P_o and P_u .

6. With dial in place, apply P_c (at center of range) to the element. If pointer reads low, link dimension L must be increased. If pointer reads high, L must be decreased. Remove dial and make adjustments as follows:
 - a. Loosen link screw and lengthen or shorten link as required. Note resulting black pointer movement. For each percent of error at P_c move black pointer about 90° . Tighten link screws.
 - b. Now restore black pointer to approximately original position by loosening scale shape adjust screw $\frac{1}{2}$ turn and moving the segment. When pointer is back to original position, lock scale shape screw.
7. Replace dial and apply P_o to element. Adjust black pointer to read correctly. Apply P_c and P_u . Note errors.
8. If error at P_u is twice error at P_c make only range adjustments (4 and 5). If not, make only scale shape adjustments (6 and 7) until the error at P_u is twice the error at P_c . Then make range adjustments per 4 and 5.

Figure 16

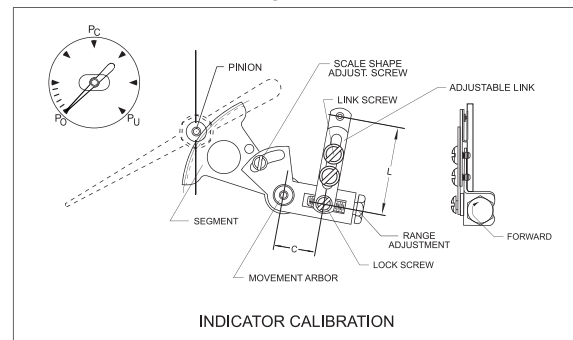

Tracking of red pointer to black is accomplished as follows (Fig. 17):

1. Reconnect control link to element and turn on supply air.

If instrument is a proportional only type set proportional band at 10% and proceed with steps 2-5.

If instrument is a proportional + reset type, trap mid-span output pressure in the reset chamber as described in TUNING PROPORTIONAL + RESET CONTROLLER. Set band at 10% and proceed with steps 2-5.



If instrument is proportional + reset + rate type, turn the rate valve on the feedback assembly to its fully open position (clockwise to stop). Trap mid-span output pressure in reset chamber as described in TUNING PROPORTIONAL + RESET CONTROLLER. Set band at 10% and proceed with steps 2-5.

2. Set element at P_o . Move red pointer with knob to obtain mid-span output. Slip red pointer on its hub so that it points to P_o and is coincident with the black pointer.
3. Set element at P_c . Move red pointer with knob to obtain mid-span output. Note whether red pointer is above or below black pointer. Repeat for P_u .
4. If red pointer reads below black pointer at P_c and P_u , dimension T must be decreased. If above, T must be increased. Remove dial and make adjustments as follows:
 - a. To decrease T (red pointer reads below black): loosen lock screw on the upper segment $\frac{1}{4}$ turn and turn tracking adjust hex backward $\frac{1}{4}$ turn per percent of tracking error at P_u .
 - b. To increase T (red pointer reads above black): loosen lock screw $\frac{1}{4}$ turn and turn tracking adjust hex forward $\frac{1}{4}$ turn per percent of tracking error at P_u .
5. Replace dial. Set element at P_o and repeat 2, 3 and 4 until red pointer coincides with black at mid-span output for all valves of measured variable.

Figure 17

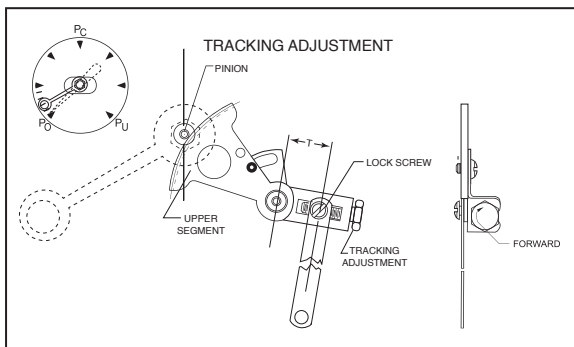

BOURDON PRESSURE ELEMENT (Fig. 18)

To remove – remove two screws on back of case holding process connection block. Unhook long control link at its lower end. This is the back link, closest to the chassis. Remove shoulder screw to set point link. Remove three element mounting screws. The upper screw is reached through the dial. Reassemble in reverse order.

To clean – if pointer action is sticky, movement pivots and teeth are probably coated with gummy oil. This can be removed by soaking entire element in suitable solvent. Caution: Remove dial before immersing.

To disassemble – if movement is damaged (usually broken or twisted hairspring or worn teeth) it is necessary to disassemble element. Remove dial by loosening two dial screws. Remove movement by unhooking measurement link and loosening two movement mounting screws. If movement can be repaired, do not loosen range adjustment screws as indicator and tracking calibration will be retained thus requiring no calibration. Reassemble in reverse order.

To calibrate – use a test gauge of known accuracy to compare with black pointer readings. A dead weight tester is satisfactory if oil in element is not objectionable. See CALIBRATION AND TRACKING INSTRUCTIONS.

Figure 18

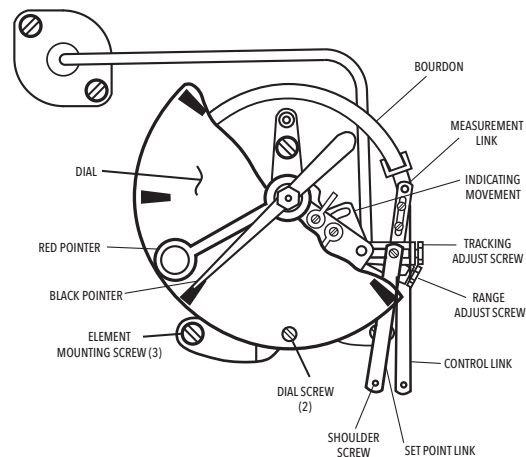



METAL DIAPHRAGM PRESSURE ELEMENT (Fig. 19)

To remove – remove two screws on back of case holding process connection block. Unhook long control link from lower tab of bell crank. Remove shoulder screw to set point link. Remove three element mounting screws. The upper screw is reached through the dial.

The diaphragm assembly may be removed by first disconnecting the diaphragm link and then loosening the locknut securing the threaded base to the mounting bracket. The replacement diaphragm assembly must be recalibrated as described below. Reassemble in reverse order.

To clean and disassemble – same as for Bourdon element.

To calibrate – use a test gauge or column of known accuracy to compare with black pointer readings. Calibration is best performed in the case. Leave control link (the long link closest to chassis) disconnected at bell crank. Connect measurement link to bell crank. Loosen bell crank angle screw and adjust angle to 80°. Lock with screw. Connect diaphragm link to bell crank in the hole which causes about 4 or 5 segment teeth to be engaged on pinion at Po. Remainder of calibration adjustment is as described in the CALIBRATION AND TRACKING INSTRUCTIONS.

Figure 19

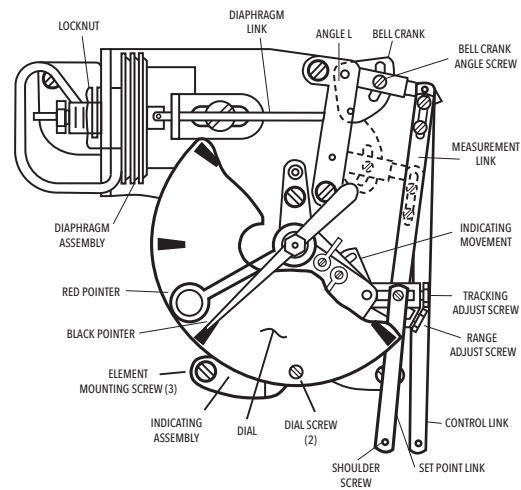

SLACK DIAPHRAGM ACTUATED PRESSURE ELEMENT (Fig. 20)

To remove indication assembly – unhook diaphragm link at bell crank. Unhook control link at its lower end. Remove shoulder screw to set point link. Remove three element mounting screws. The upper screw is reached through the dial.

To remove diaphragm housing assembly – unhook diaphragm link at bell crank. Remove three screws securing diaphragm housing to columns and bracket on back of case.

Figure 20

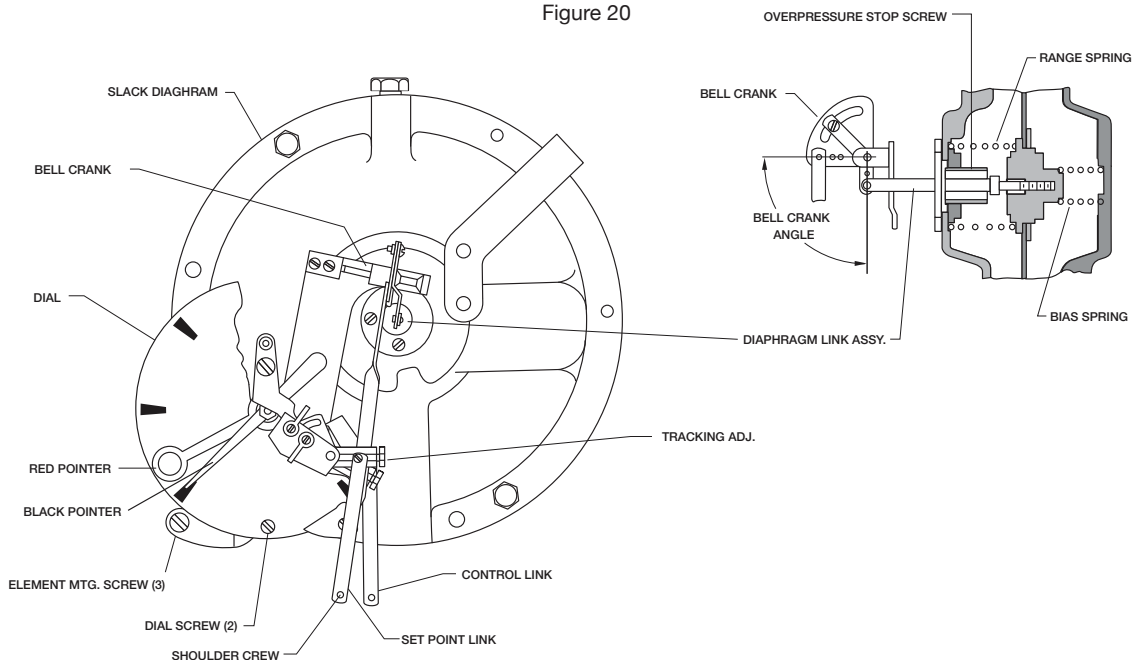



Reassemble in reverse order.

To adjust overpressure stop – (before reassembly to instrument) turn overpressure stop screw counterclockwise, at least three turns. Apply full scale pressure and turn stop screw clockwise until water column meniscus is disturbed. Back off ½ turn.

To clean indicating assembly – same as Bourdon element.

To calibrate – use a manometer or inclined manometer of known accuracy to compare with black pointer readings. Element must be assembled in case. Disconnect control link (short link closest to the chassis) from the tab on the indicating movement. Set bell crank angle at 90°. Adjust diaphragm link to engage 4 or 5 segment teeth on pinion at Po by unhooking it at bell crank and turning it clockwise to shorten, counterclockwise to lengthen. Proceed with calibration as described under CALIBRATING AND TRACKING INSTRUCTIONS, except for the scale shape adjustment. If Pc is too high or low (item 6 under CALIBRATION OF ELEMENT), adjust bell crank angle and make appropriate diaphragm link adjustment to engage 4 or 5 teeth at Po.

SLACK DIAPHRAGM ACTUATED DIFFERENTIAL PRESSURE, VACUUM ELEMENT, COMPOUND ELEMENT (Fig. 21)

To replace indicating assembly – same as Slack Diaphragm Pressure Element.

To clean indicating assembly – same as Bourdon element.

To adjust high pressure stop:

1. Loosen H.P. stop at least 3 turns.
2. Pressure and compound ranges – apply full scale pressure to H. P. side. Vacuum ranges – apply full scale vacuum to L.P. side.
3. Adjust H.P. stop clockwise until column meniscus is disturbed, then back off ½ turn.

To adjust low pressure stop:

1. Loosen L.P. stop at least 3 turns.
2. Pressure ranges-apply min. pressure to H.P. side. Compound ranges-apply full scale vacuum to H.P. side. Vacuum ranges-apply min. vacuum to L.P. side.
3. Adjust L.P. stop clockwise until column meniscus is disturbed, then back off ½ turn.

To calibrate – same as for slack diaphragm pressure element except as follows:

Pressure and compound ranges – apply Po, Pc, and Pu to H.P. side with L.P. side open.
Vacuum Ranges – apply Po, Pc, and Pu to L.P. side with H.P. side open.

Figure 21

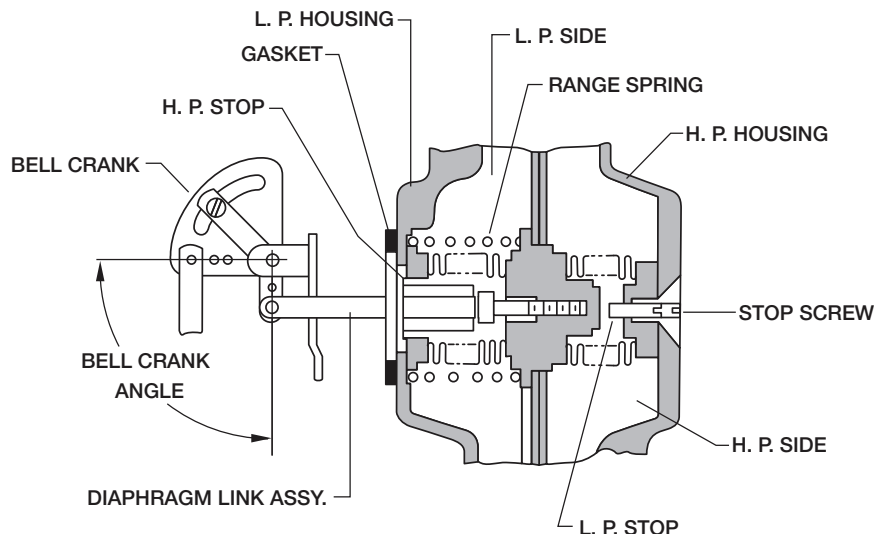



HIGH STATIC PRESSURE ACTUATED DIFFERENTIAL PRESSURE ELEMENT (Fig. 22)

To remove Indicating Assembly – remove (2) length adjust screws on the measurement link and unhook control link at its lower end. Remove shoulder screw to setpoint link. Remove (3) element mounting screws. The upper screw is reached through the dial. Reassemble in reverse order.

To remove Differential Pressure Element – remove (2) length adjust screws on the measurement link. Loosen stop arm with 0.25” hex wrench and remove shaft clamp.

For Barton 224 D/P Element – remove chassis as instructed under MAINTENANCE-CHASSIS and remove (4) D/P element mounting screws.

For Barton 199 D/P Element – remove (4) D/P element mounting screws from rear of case. Reassemble in reverse order.

To clean Indicating Assembly – same as Bourdon element.

To calibrate – disconnect control link from the tab on the indicating movement. Move high and low stops to the edge of the slot in chassis. Loosen (2) length adjust screws on the measurement link assembly. Adjust stop arm so that it is in the center of the slot in chassis and tighten using 0.25” hex wrench. Maintain minimum clearance between the shaft clamp and the bearing of the D/P element. Adjust take off arm to 0.81” (21 mm) from chassis. Apply P_o and adjust length of measurement link to engage 4 or 5 segment teeth on pinion. Adjust low stop to clear stop arm by 0.01” (0.25mm). Apply P_u and adjust high stop to clear stop arm by 0.01” (0.25mm). Apply 2 x P_u to L.P. side then to H.P. side to determine if stop arm and stops are secured. If not readjust stop arm clearance. Proceed with calibration as described under CALIBRATION AND TRACKING instructions.

Apply P_o , P_c and P_u to D/P elements as follows: For pressure and compound ranges – H.P. side with L.P. side vented. For vacuum ranges – L.P. side with H.P. side vented.

Figure 22

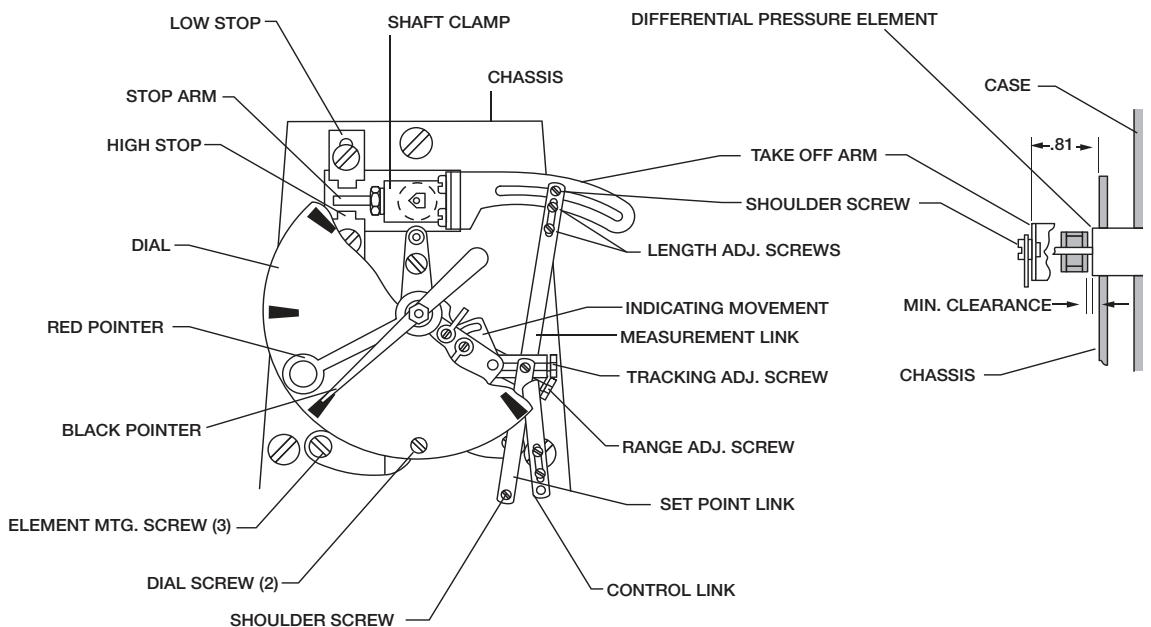



Chassis (Fig. 23)

To remove Chassis – remove element from chassis per instructions under MEASURING ELEMENT. Remove nozzle line and feedback line from relay. Remove three chassis mounting screws. Replace in reverse order.

To clean Flapper – air from nozzle will deposit a gummy residue on the flapper after extended service. This may be removed with a dry cloth or a cotton swab soaked in solvent.

THE DOOR

The door assembly may be removed by depressing upper hinge pin with a drill through hole in dust ledge. When pin is free of hole, door may be manipulated to withdraw the lower pin from the lower ledge hole. Pins are trapped and cannot be lost. To replace, insert lower pin in hole first. Depress upper pin and slip under upper ledge. Manipulate door until upper pin jumps into upper hole.

Figure 23

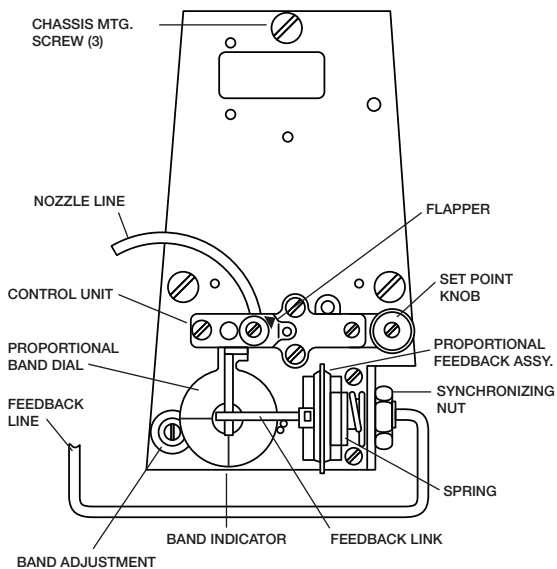

Filter Fittings (Figs. 24, 25)

A gradual drop in supply pressure is usually caused by filters being gradually closed up with oil and dirt. This will cause slower controller response which may cause process cycling. Therefore it is good to periodically clean the filters.

The filter element in the supply filter assembly can be cleaned without disconnecting the piping by removing the cap screw. Remove filter element and clean with solvent. Reassemble in reverse order.

Figure 24

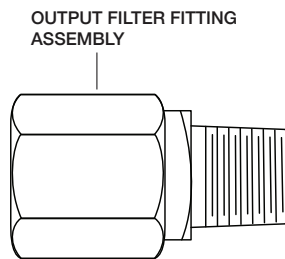

Figure 25

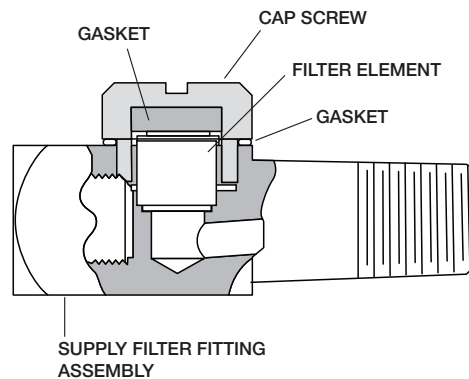
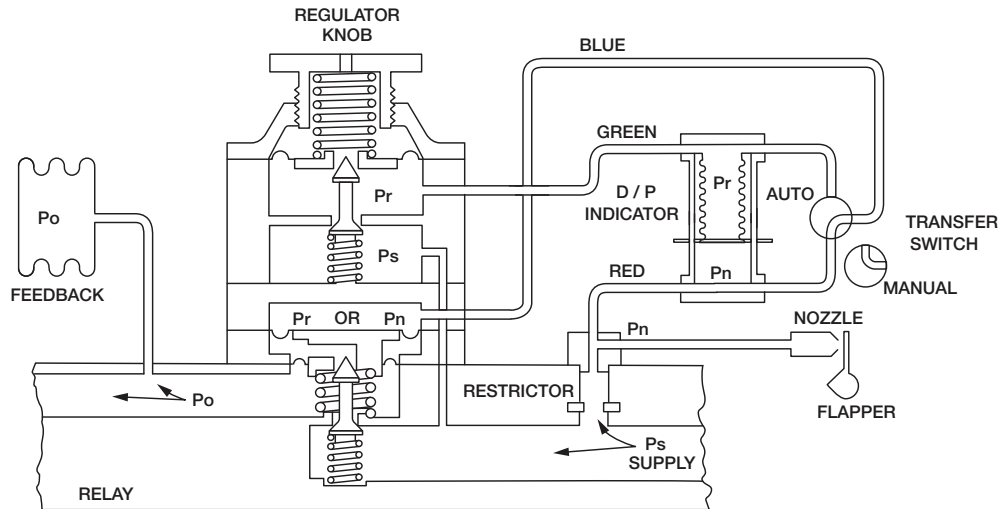



Figure 26

SPECIAL CONTROLLERS



TWO POSITION BYPASS CONTROLLER

General

The two position bypass allows the process to be controlled automatically or manually with provision for bumpless transfer.

PRINCIPLE OF OPERATION (Figs. 26, 27)

A three-way valve in the nozzle line between the restrictor and the relay nozzle diaphragm permits operation of controller output either automatically (nozzle-flapper system) or manually by using a pressure regulator mounted on top of the relay.

Bumpless transfer is facilitated by a differential pressure indicator which responds to very low pressure differentials. This makes it possible to closely match regulator pressure P_r to nozzle pressure P_n .

With this system, manual control is accomplished through the controller's output air delivery system. Air delivery and control response are identical for automatic and manual conditions.

Figure 27

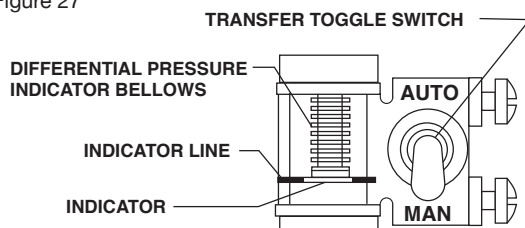

OPERATING PROCEDURE

Manual to Automatic – assume the transfer switch is in the “MAN” position and the process is stable and being controlled manually by the regulator on top of the relay.

1. Adjust set point knob until the end of the Differential Pressure indicator bellows is aligned with indicator line. This matches the nozzle back pressure P_n to the regulator pressure P_r .
2. Flip the transfer switch toggle to the “AUTO” position and the controller assumes control of the process. Turn regulator knob counterclockwise to stop, (to shut off regulator output).

Automatic to Manual – assume process is stable and being controlled by the controller.

1. Adjust the regulator knob until the end of the Differential Pressure indicator bellows is aligned with indicator line. The regulator pressure P_r is then the same as nozzle back pressure P_n .
2. Flip the transfer switch toggle to the “MAN” position. The process is now being controlled manually. Output can be increased by turning the regulator adjust knob clockwise or decreased by turning counterclockwise.



REPLACEMENT PARTS LIST

BOURDON TUBE PRESSURE ELEMENT

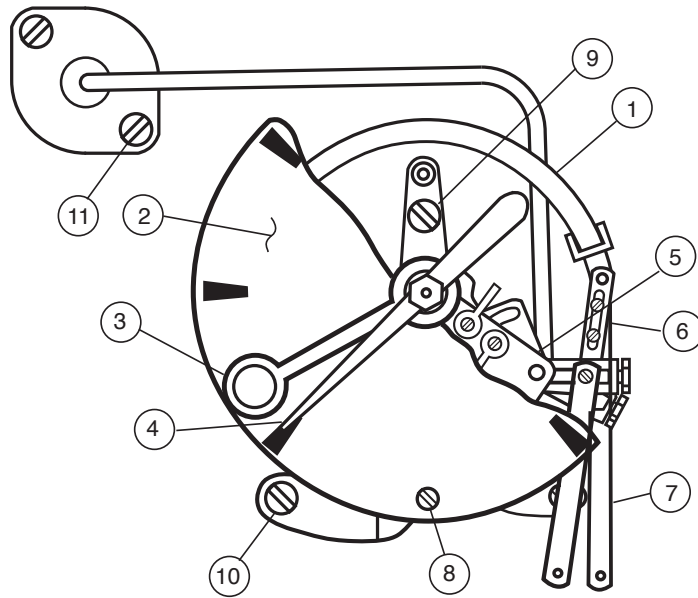

RECOMMENDED SPARE PARTS

Precalibrated assembly includes the parts listed below.
TO ORDER: Specify material, range and dial

ITEM	PART NUMBER	DESCRIPTION
1	See Table	Bourdon element
2	Specify Range	Dial
3	P-505-A New #P249505	Control Set Pointer
4	P-231-11 New #P032612	Indicating Pointer
5	M-176-BH New #M021636	Indicating Movement
6	N-2027-FP New #N241194	Link Assy.
7	N-2027-BO New #N241010	Control Link
8	K803205	Dial Screw 2-56 x .13 (2 required)
9	K800805	Mounting Screw 8-32 x .63
10	K800803	Mounting Screw 8-32 x.38 (2 req'd)
11	K802803	Conn.Mtg. Screw 8-32 x.38 (2 req'd)



STANDARD ELEMENTS

MATERIAL	RANGE		BOURDON ELEMENT NEW #	OLD PART#
	INCHES HG or PSI	PASCAL		
PHOS.BRONZE	-30/0 IN HG	-100/0 kPa	Z098642	98053
	0/13 to 0/17 PSI	0/90 to 0/110 kPa	Z098642	98053
	0/25 to 0/35 PSI	0/170 to 0/240 kPa	Z098644	98053
	0/50 to 0/70 PSI	0/340 to 0/480 kPa	Z098647	98053
	0/85 to 0/110 PSI	0/580 to 0/800 kPa	Z098648	98053
	0/190 to 0/230 PSI	0/1300 to 0/1600 kPa	Z098652	98053
	0/250 to 0/350 PSI	0/1700 to 0/2400 kPa	Z098653	98053
	316 STAINLESS STEEL	-30/0 IN HG	-100/0 kPa	Z098666
0/13 to 0/17 PSI		0/90 to 0/110 kPa	Z098666	98064
0/25 to 0/35 PSI		0/170 to 0/240 kPa	Z098667	98065
0/50 to 0/70 PSI		0/340 to 0/480 kPa	Z098669	98066
0/85 to 0/110 PSI		0/580 to 0/800 kPa	Z098671	98067
0/150 to 0/180 PSI		0/1000 to 0/1200 kPa	Z098673	98090
0/190 to 0/230 PSI		0/1300 to 0/1600 kPa	Z098674	98068
0/250 to 0/350 PSI		0/1700 to 0/2400 kPa	Z098675	98069
0/350 to 0/450 PSI		0/2400 to 0/3100 kPa	Z098676	98102
0/450 to 0/550 PSI		0/3100 to 0/3800 kPa	Z098677	98109
0/550 to 0/700 PSI		0/3800 to 0/4800 kPa	Z098678	98070
0/700 to 0/900 PSI		0/4800 to 0/6200 kPa	Z098679	98170
0/900 to 0/1200 PSI		0/6200 to 0/8000 kPa	Z098680	98071
0/1300 to 0/1700 PSI		0/9 to 011 mPa	Z098682	98698
0/1700 to 0/2300 PSI		0/12 to 016 mPa	Z098683	98699
0/2500 to 0/3500 PSI	0/17 to 024 mPa	Z098685	98701	



DIAPHRAGM ACTUATED ELEMENTS

Pre-calibrated assembly includes the parts listed below. TO ORDER: Specify material, range, dial, link assy. (from table) and whether diaphragm is used for pressure or vacuum. Assembly can be interchangeable with bourdon type.

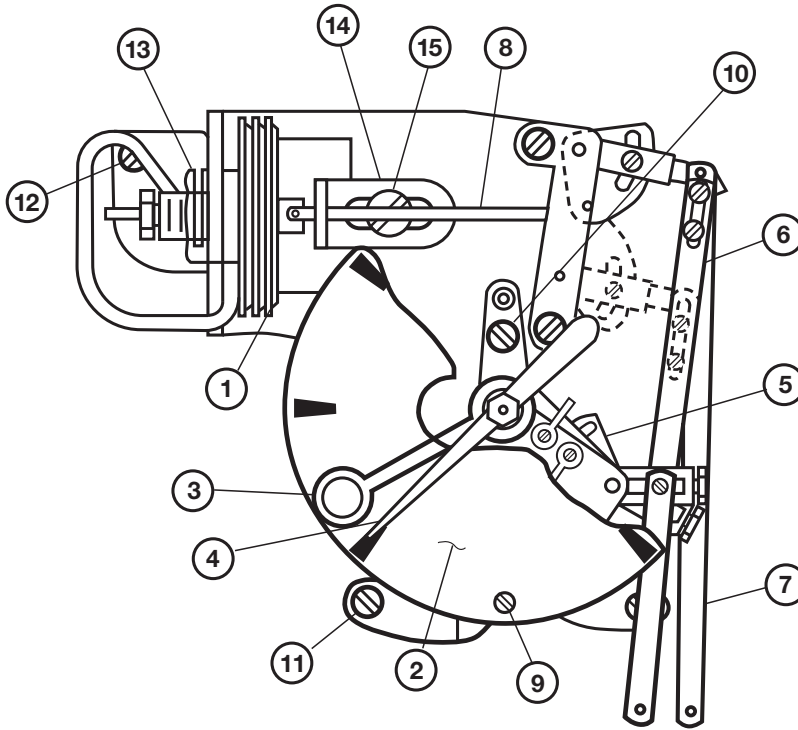

RECOMMENDED SPARE PARTS

ITEM	PART NUMBER	DESCRIPTION
1	See Table	Diaphragm Element
2	Specify Range	Dial
3	P-505-A New #P249505	Control Set Pointer
4	P-231-11 New #P032612	Indicating Pointer
5	M-176-BH New #M021636	Indicating Movement
6	N-2027-FV New #N241208	Link Assy. (Pressure)
	N-2027-FU	Link Assy. (Vacuum)
7	N-2027-EO New #N241165	Link Assy. (Pressure)
	N-2027-EP	Link Assy. (Vacuum)
8	See Table	Link Assembly
9	K803205	Dial Screw 2-56 x .13 (2 req'd)
10	K800805	Mounting Screw 8-32 x .63
11	K800803	Mounting Screw 8-32 x .38 (2 req'd)
12	K802803	Conn. Mtg. Screw 8-32 x .38 (2 req'd)
13	H-501-DC New #H017135	Locknut
14	H-6185-G New #H552147	Stop (Optional)
15	K802700	Screw 12-24 x .25 (optional)



STANDARD ELEMENTS

MATERIAL	RANGE		DIAPHRAGM ELEMENT	PRESSURE LINK ASSEMBLY	VACUUM LINK ASSEMBLY
	INCHES HG or PSI	PASCAL			
NI-SPAN C	0/50 to 0/60 " H ₂ O	0/12 to 0/15 kPa	N281236	N241280	N241280
	0/66 to 0/105" H ₂ O	0/16 to 0/26 kPa	N281238	N241173	N241173
	0/9 to 0/12 PSI	0/16 to 0/26 kPa	N281280	N241188	N/A
	3/15 PSI	0/20 to 0/100 kPa	N281280	N241188	N/A
316 STAINLESS STEEL	0/50 to 0/60 " H ₂ O	0/12 to 0/15 kPa	N281266	N241173	N241173
	0/90 to 0/110" H ₂ O	0/22 to 0/27 kPa	N281268	N241174	N241188
	0/120 to 0/160" H ₂ O	0/30 to 0/40 kPa	N281269	N241174	N241188
	3/15 PSI	0/20 to 0/100 kPa	N281273	N241188	N/A
	0/6 to 0/8 PSI	0/41 to 0/55 kPa	N281270	N241188	N241173
	0/8 to 0/11 PSI	0/55 to 0/75 kPa	N281272	N241174	N241188
	0/11 to 0/13.5 PSI	0/75 to 0/93 kPa	N281273	N241188	N/A



SLACK DIAPHRAGM ACTUATED PRESSURE ELEMENTS

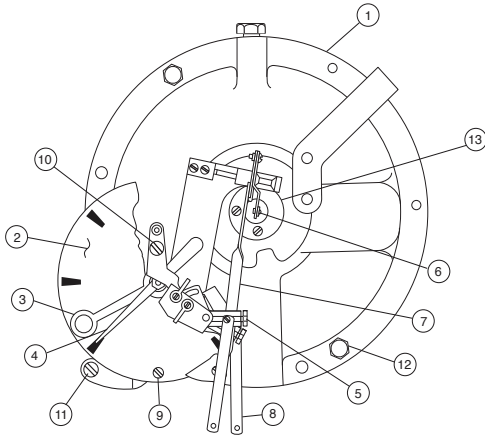

This element includes diaphragm housing assembly, mounting posts, indicating movement, links, cast mounting bracket, dial and pointers. It is not pre-calibrated when purchased as replacement and is not interchangeable with other element types.

*Differential pressure units can be used to 15 PSI max. static pressure.

RECOMMENDED SPARE PARTS

ITEM	PART NUMBER		DESCRIPTION		
	1	Housing Assy. Pressure	*Housing Assy. Diff. Pressure	Range	
Inches/Water				Pascal (kPa)	
98339		98324	0/4.5 to 0/8.4	0/1 to 0/2	
98329		98325	0/8.5 to 0/14.5	0/2 to 0/3.6	
98330		98326	0/14.6 to 0/24.9	0/3.6 to 0/6	
98331		98327	0/25 to 0/43.9	0/6 to 0/11	
98332		98328	0/45 to 0/80	0/11 to 0/20	
* Housing Assembly (Diff. Pressure) Center Zero Ranges					
			Inches Water	Pascal (kPa)	
			4.5/0/4.5 to 8.4/0/8.4	1/0/1 to 2/0/2	
			8.5/0/8.5 to 14.5/0/14.5	2/0/2 to 3.6/0/3.6	
			14.6/0/14.6 to 24.9/0/24.9	3.6/0/3.6 to 6/0/6	
			25/0/25 to 43.9/0/43.9	6/0/6 to 11/0/11	
		44/0/44 to 80/0/80	11/0/11 to 20/0/20		
	PART NUMBER	DESCRIPTION			
2	Specify Range	Dial			
3	P-505-A New #P249505	Control Set Pointer			
4	P-231-11 New #P032612	Indicating Pointer			
5	M-176-BI New #M021637	Indicating Movement			
6	N-2027-FW New #N241210	Diaphragm Link			
7	N-2027-FD New #241180	Link Assembly			
8	N-2027-DL New #241122	Control Link			
9	K803205	Dial Screw 2-56 x .13 (2 required)			
10	K800805	Mounting Screw, 8-32 x .63			
11	K800803	Mounting Screw, 8-32 x .38 (2 required)			
12	K810805	Post Mounting Screw #8 Type F Self-Thread (3 required)			
13	H-2025-WG New #H074807	Gasket			



DIFFERENTIAL PRESSURE ELEMENTS

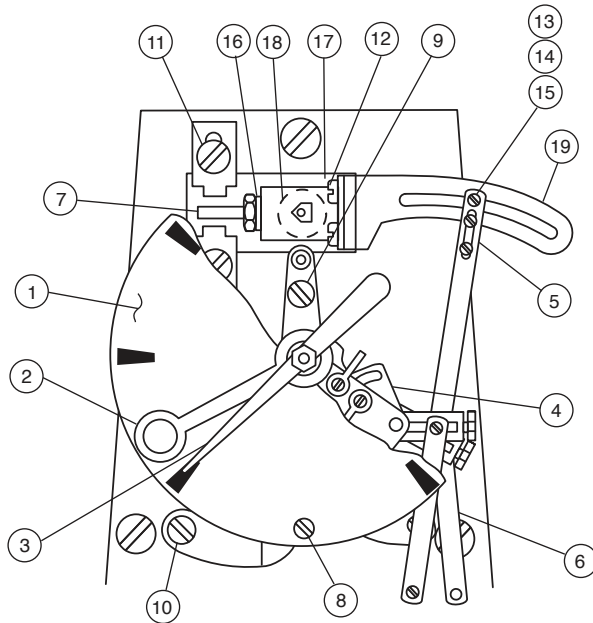

FOR REPLACEMENT DIFFERENTIAL PRESSURE ELEMENTS SPECIFY: Type, Range, Housing Material, Bellows Material and Static Process Pressure.

MOUNTING SCREWS FOR D/P (Not shown)

Barton 199 - 1/4 - 20 x .50 K806703 (4 required)

Barton 224 - #10-32 x .50 K802905 (4 required)

RECOMMENDED SPARE PARTS

ITEM	PART NUMBER	DESCRIPTION
1	Specify Range	Dial
2	P-505-A New#P249505	Control Set Point
3	P-231-11 New#P032612	Indicating Pointer
4	M-176-BI New#M021637	Indicating Movement
5	K-640043	Link Assembly
6	N-2027-DL New#N241122	Control Link
7	K-280058	Stop Arm
8	K-803205	Dial Screw 2-56 x .13 (2 required)
9	K-800805	
10	K-800803	
11	K-803801	Stop Screw 8-32 x .28 (2 required)
12	K-803401	Arm Screw 4-40 x .13 92 required)
13	H-98-BL	Shoulder Screw
14	H-616 New#H019101	Washer
15	E-98-AC New#E026050	Link Adjustment Nut
16	K-860403	Washer
17	K-110014	Shaft Clamp
18	K-010060	Bushing
19	K-280060	Takeoff Arm



DOOR ASSEMBLIES

(Includes Door & Items 1 thru 11)

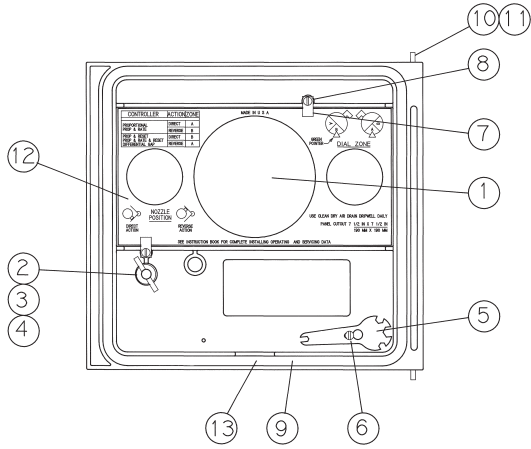

TYPE	DOOR ASSY.	NEW PART #
Standard	99647	K721046
W/Shatterproof Glass	99649	K721047
W/External Set Pointer	99648	K721050
W/Shatterproof Glass & External Set Pointer	97021	K721051
Standard Anodized	97429	current
Standard Anodized W/ Shatterproof Glass	97447	current

CASE ASSEMBLIES

(Includes Case & Items 14 & 15)

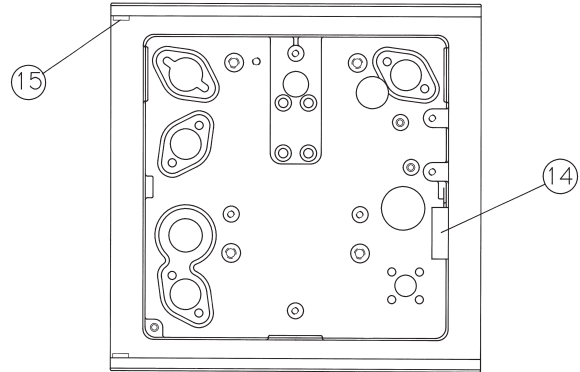

TYPE	CASE ASSY.	NEW PART #
Standard	99741	K070843
2 Pos. ByPass	99750	K070857
Slack Diaphragm	99761	K070893
Barton 224 D/P	99763	K070845
BARTON 199 D/P	99895	K070864

RECOMMENDED SPARE PARTS

ITEM	PART #	DESCRIPTION	
1	G-114	New#G096900	Glass, standard
	G-119	New#G100400	Glass, shatterproof
2	N-2127	New#N310700	Shaft, pin & "E" Ring
*3	K010088		Bushing, latch
4	K101003		Knob
5	K909001		Wrench
6	K803405		Screw Wrench
*7	K110066		Shroud clip (2 req'd)
8	K800400		Screw Shroud 4-40 x .12 (2 req'd)
*9	K230045		Door Gasket
10	H-6070-H	New#H517920	Pin (2 req'd)
11	H-202-AO	New#H009188	Spring, door
12	K190250		Shroud, standard
	K190251		Shroud, W/Supply gauge
*13	K230046		Gasket, for AP option
14	85509		Door Catch Assy.
15	K010028		Bushing (2 req'd)

* Cannot be used on instruments built before 1990



CHASSIS ASSEMBLY

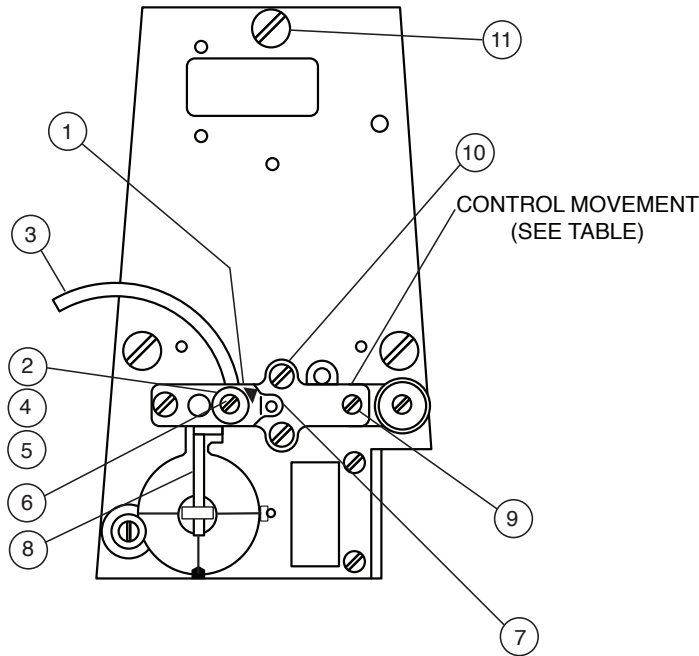

CHASSIS ASSEMBLY – includes backplate assy., control movement, nozzle, flapper, proportional band link and control setting knob. To attach nozzle tubing to pre-1978 relays, order K080068 barb assembly

PROP BAND	CONTROL MOVEMENT	CHASSIS ASSEMBLY	NEW PART #
100%	M-503	99475	K721002
200%	M-503	99156	K721002
300%	M-503	99799	K721002

CHASSIS ASSEMBLY W/FEEDBACK includes chassis assembly, feedback assembly, and mounting screws. Precalibrated for reversibility and control point alignment. To attach nozzle & feedback tubing to pre-1978 relays, order two k080068 barb assemblies

PROP BAND	CHASSIS ASSY. W/FEEDBACK	NEW PART #
100% w/3-15 Prop. Feedback	99150	K721002 + K721022
100% w/6-30 Prop. Feedback	99156	K721002 + K721023
200% w/3-15 Prop. Feedback	99186	K721002 + K721025
200% w/6-30 Prop. Feedback	99187	K721002 + K721026
200% w/3-15 Reset Feedback	99189	K721002 + K721028
200% w/6-30 Reset Feedback	99190	K721002 + K721029
300% w/3-15 PID Feedback	99927	K721002 + K721037



RECOMMENDED SPARE PARTS

ITEM	PART NUMBER		DESCRIPTION
1	H-6096-F	New#H528498	Nozzle
2	H-6097-C	New#H528680	Nozzle Block
3	K270093		Nozzle tubing
4	K080067		Block & Barb
5	H-2025-KN	New#H073923	“O” Ring
6	H-106-CB	New#H005547	Nozzle Screw
7	N-2119-A	New#N305105	Flapper
8	H-6014-CB	New#H504266	Link
9	H-98-BL	New#H004573	Link Screw
10	K800401		Movt. Screws 4-48 x .19 (3 required)
11	K803804		Mtg. Screw 8-32 x .38 (3 required)



STANDARD RELAY (Recommended Spare Parts)

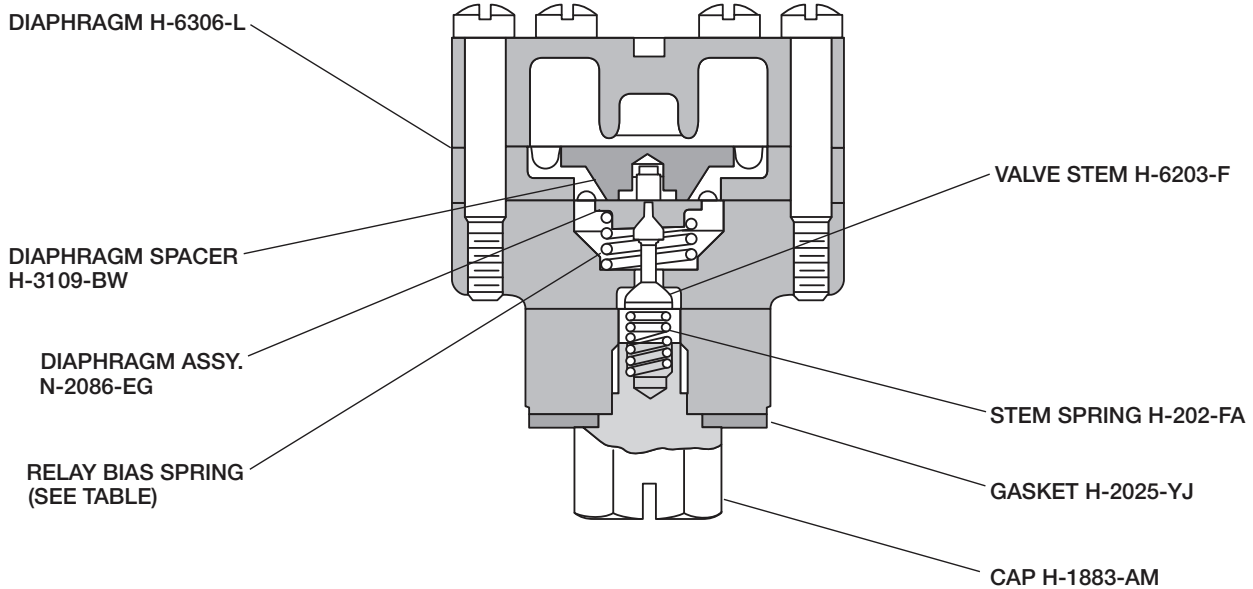

RELAY W/REGULATOR (Recommended Spare Parts)

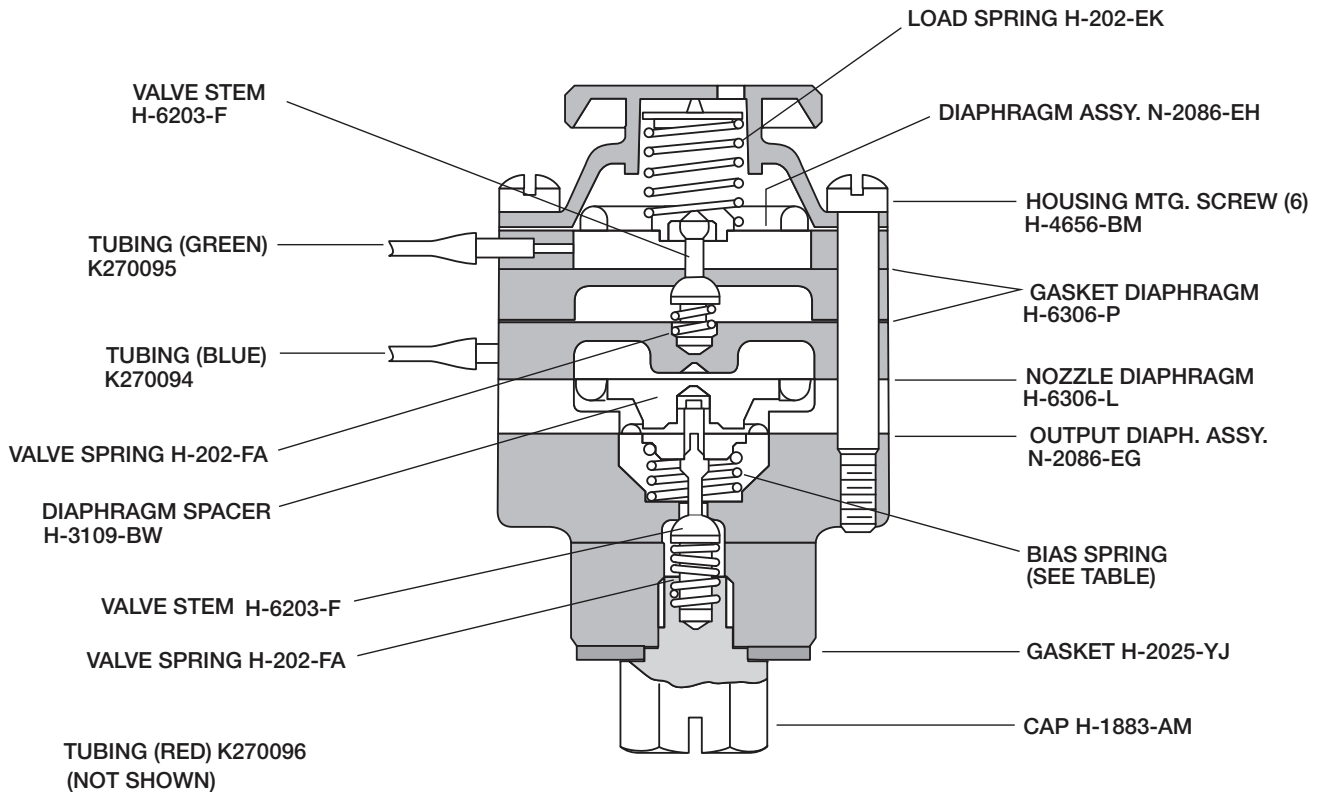

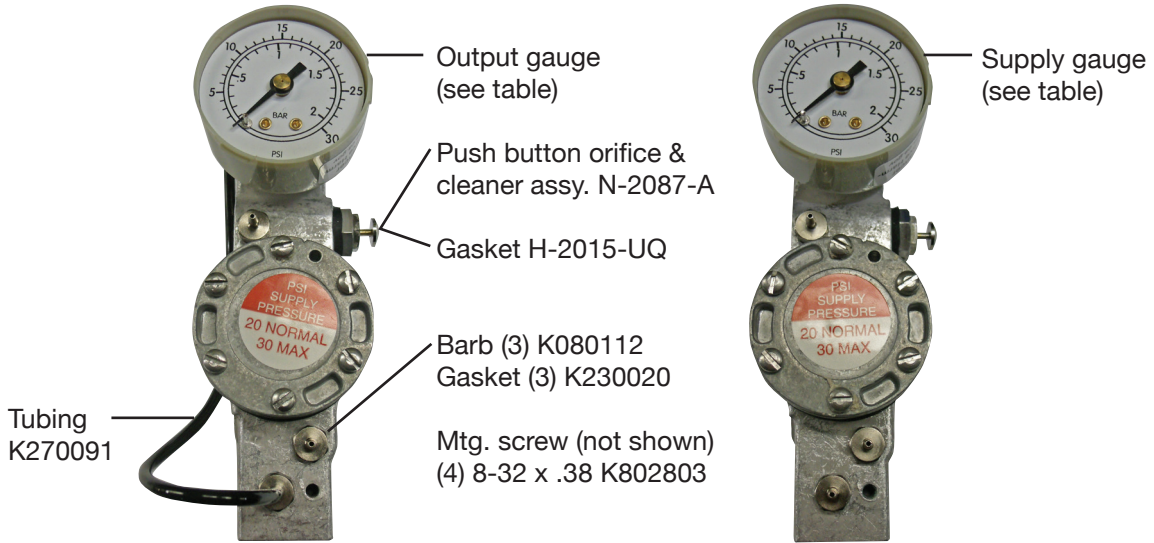

RELAY WITH OUTPUT GAUGE

RELAY WITH SUPPLY GAUGE

PSI	PASCAL	TYPE	RELAY ASSY. W/ OUTPUT GAUGE	RELAY ASSY. W/ SUPPLY GAUGE
3/15	20/100 kPa	Standard	99771	99787
6/30*	40/200 kPa	Standard	99772	99788
12/60	80/400 kPa	Standard	99773	99789
3/15	20/100 kPa	w/Regulator	99774	99790
6/30*	40/200 kPa	w/Regulator	99775	99791
3/15	20/100 kPa	D/P	99885**	99890**
6/30*	40/200 kPa	D/P	99886**	99891**
12/60	80/400 kPa	D/P	99887**	99892**
3/15	20/100 kPa	D/PW/Regulator	99888**	99893**
6/30*	40/200 kPa	D/PW/Regulator	99889**	99894**
		OUTPUT GAUGE	SUPPLY GAUGE	BIAS SPRING
3/15	20/100 kPa	N-2024-Y	N239513	H009217
6/30*	40/200 kPa	N-2024-Z	N239515	H009303
12/60	80/400 kPa	N-2024-AP	N240006	H009303

* Can be used for 3-27 PSI (20/186 kPa)

** Includes supply tubing K270112, side connection block K670049, & elbow K080120 (Not Shown)

BAG OF (10) REPLACEABLE
FILTER ELEMENTS
SPEC. #85688

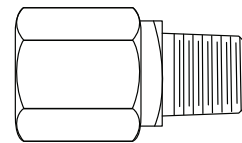
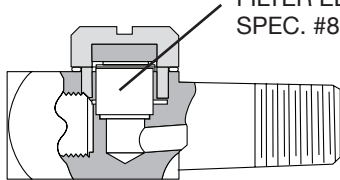

SUPPLY FILTER FITTING N-1541-B
(N222928)

OUTPUT FILTER FITTING
N-1541-A (N222900)



MULTI-MODE FEEDBACK ASSEMBLIES

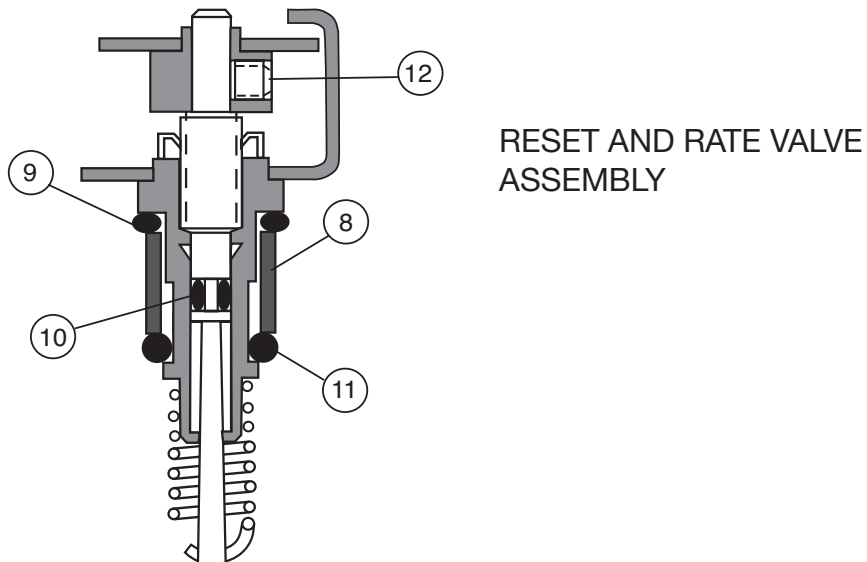
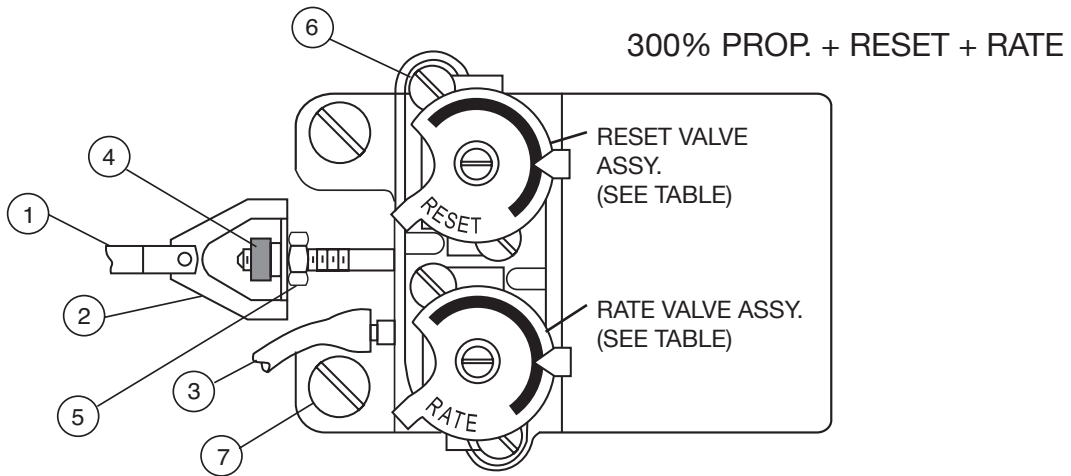
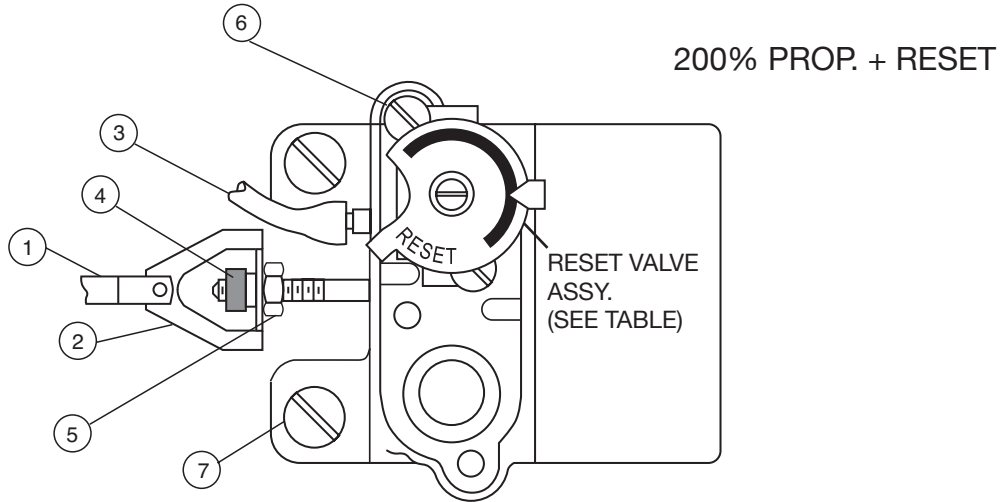



MULTI-MODE FEEDBACK ASSEMBLY					
MODE	OUTPUT PRESSURE		VALVE ASSY.	COMPLETE ASSY.	NEW PART #
	PSI	PASCAL			
200% + Reset	3/15	20/100 kPa	K671019	99836	K721028
200% + Reset	6/30	40/200 kPa	K671019	99837	K721029
300% Prop + Reset + Rate	3/15	20/100 kPa	K671019	99859	K721037
		(fast reset)	K671020		
300% Prop + Reset + Rate	6/30	40/200 kPa	K671019	99860	K721038
		(fast reset)	K671020		

COMPLETE ASSEMBLY – includes capsule assy., valve assy., link, adjust link, tubing, knurl nut, hex nut, valve mtg. screws, and feedback mtg. screws. To attach tubing to pre-1978 relays, order K080068 Barb Assembly.

RECOMMENDED SPARE PARTS

ITEM	PART NUMBER	DESCRIPTION
1	N-2027-JA New#N241290	Link Assy., 200% Prop.
	N-2027-CR New#N241090	Link Assy., 300% Prop.
2	K150010	Adj. Link
3	K270101	Tubing
4	K880006	Knurl Nut
5	K852000	Hex Nut 2-56
6	K800402	Valve Screw 4-40 x .25 (2 required per valve)
7	K803802	Mtg. Screw 8-32 x .25 (2 required)
8	K200018	Filter
9	H-2025-JE New#H073813	'O' Ring
10	H-2025-LH New#H073987	'O' Ring
11	K232013	'O' Ring
12	K808401	Set Screw 4-40 x .13 (2 required)



PROPORTIONAL FEEDBACK ASSEMBLIES

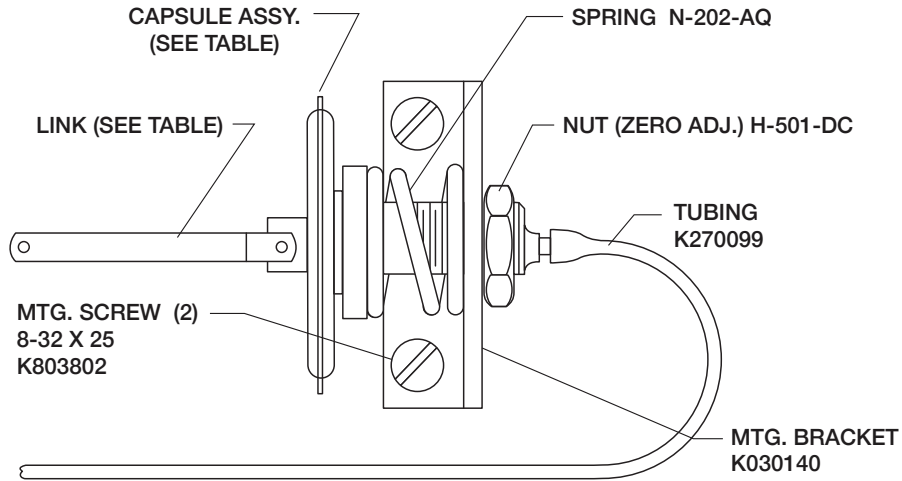

COMPLETE ASSEMBLY includes Capsule Assy., Mtg. Bracket, Spring, Nut, Tubing, Link & Mtg. Screws. To attach tubing to pre-1978 relays order K080068 Barb Assembly.

BAND	OUTPUT PRESSURE		LINK	CAPSULE ASSY.	NEW PART #	COMPLETE ASSY.	NEW PART #
	PSI	PASCAL					
1-100%	3/15	20/100 kPa	N241020	99847	N281295	99868	K721022
1-100%	6/30	40/200 kPa	N241020	99848	N281722	99869	K721023
2-200%	3/15	20/100 kPa	N241090	99845	N281527	99866	K721028
2-200%	6/30	40/200 kPa	N241090	99846	N281207	99867	K721029
2-200%	12/60	80/400 kPa	N241090	99849	N281218	99870	K721027

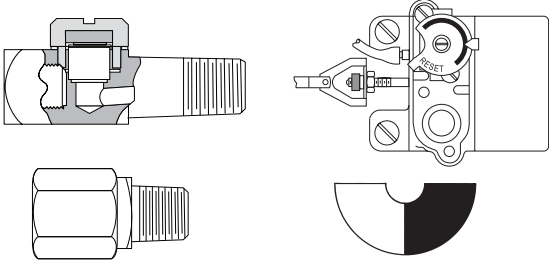
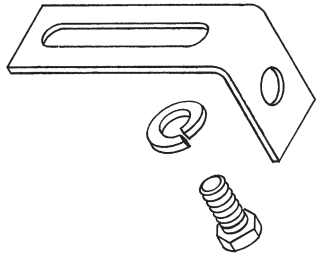
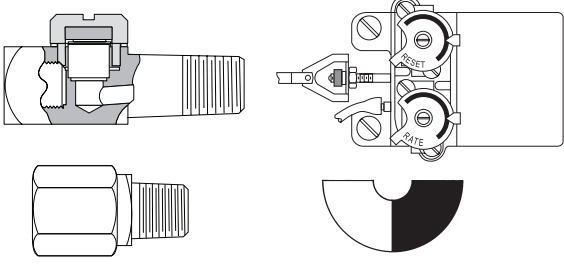
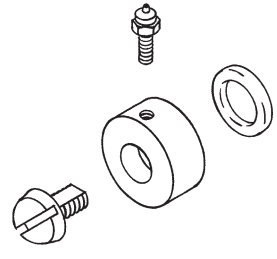
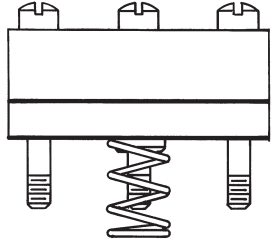
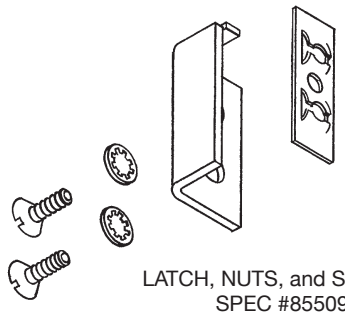
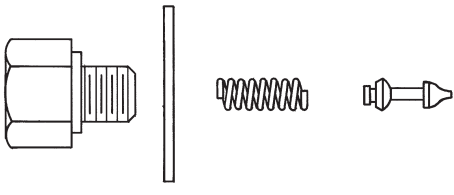

REPLACEMENT PARTS KITS

 <p>MODIFICATION KIT W/FEEDBACK, VALVE, FILTERS, DECAL AND INSTRUCTIONS 3-15 OUTPUT SPEC. #99863 6-30 OUTPUT SPEC. #99864</p>	 <p>MTG BRACKETS, SCREWS AND WASHERS (SET OF 2) SPEC. #99811</p>
 <p>RESET + RATE MODIFICATION KIT W/FDBK, VALVE, FILTERS, DECAL AND INSTRUCTIONS 3-15 OUTPUT SPEC. #99913 6-30 OUTPUT SPEC. #99914</p>	 <p>NOZZLE, BLOCK, "O" RING, SCREW, and NOZZLE LINE ASSY. SPEC. #99844</p>
<p>BLACK PLASTIC TUBING 1/16 ID X 1/8 OD X 36 Inches long. PART NO. K270127 (Can be cut to length to replace all K270...tubing except K270112 on D/P relays)</p>	 <p>DIAPHRAGM HOUSING W/DIAPHRAGMS, BIAS SPRING and MOUNTING SCREWS. 30 psi SPEC #99548 60 psi SPEC #99549</p>
 <p>LATCH, NUTS, and SCREWS SPEC #85509</p>	 <p>RELAY CAP, GASKET, SPRING & STEM SPEC #99547</p>



OPTIONS

Recommended Spare Parts

OUTPUT GAUGE ASSEMBLY

PSI	BARS	COMPLETE ASSY.
0-30	0-2	99851
0-60	0-4	99852
0-100	0-7	99853

For output gauge only, see page 31

Complete assembly includes output gauge, bracket, tubing and mounting screw. For pre-1978 instruments, use output gauge from page 34, K270092 and K080068 barb assembly.

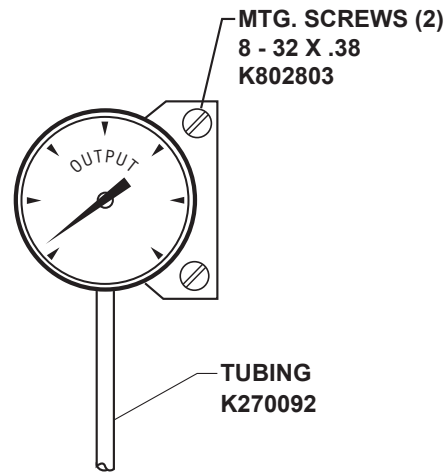

TWO POSITION BY-PASS (auto/manual)- K614001 for 3/15 or 6/30 psi output.

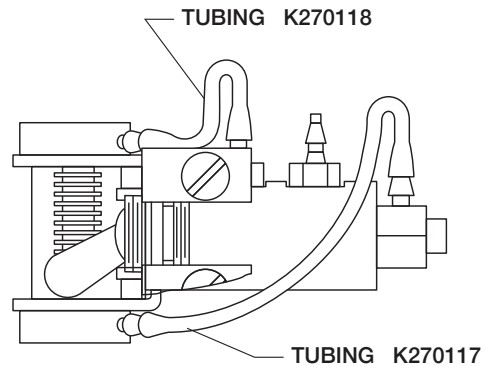
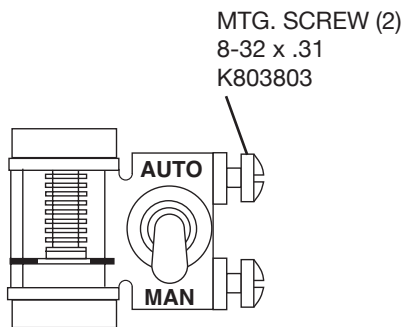

EXTERNAL RESET FEEDBACK

PSI	PASCAL	COMPLETE ASSEMBLY
3/15	20/100 kPa	99841
6/30	40/200 kPa	97009

COMPLETE ASSEMBLY includes capsule assy., reset valve, connector, capsule mounting screws, connector mounting screws and tubing. To attach tubing to pre-1978 relays order K080068 Barb Assembly.

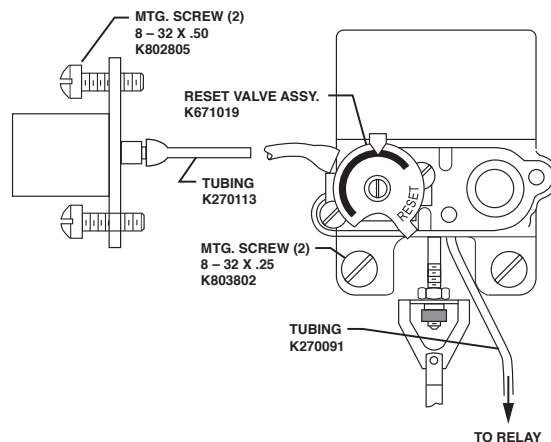



OPTIONS

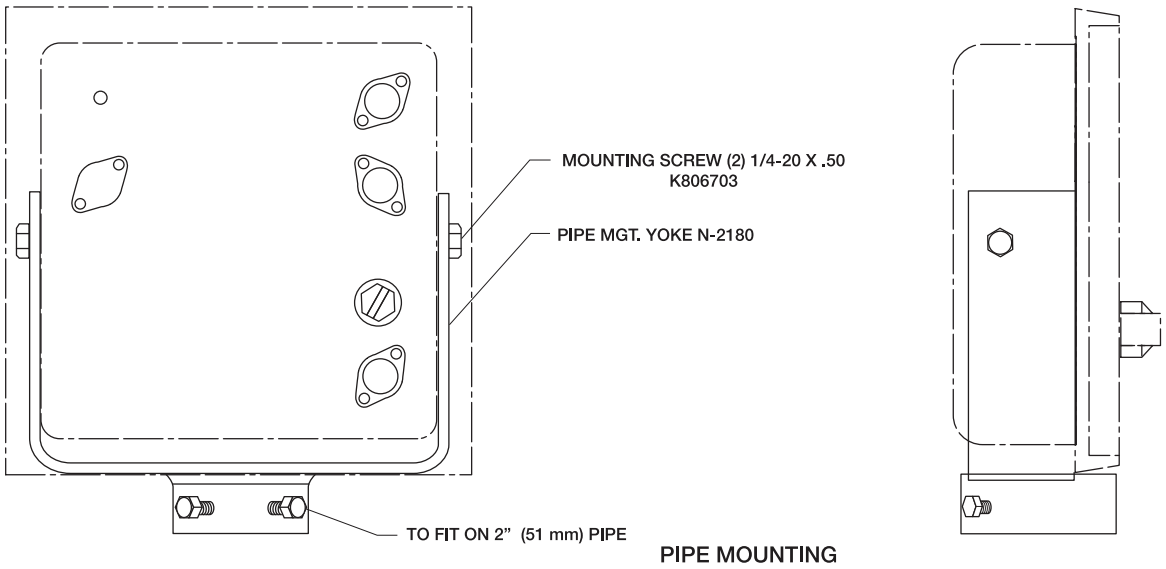
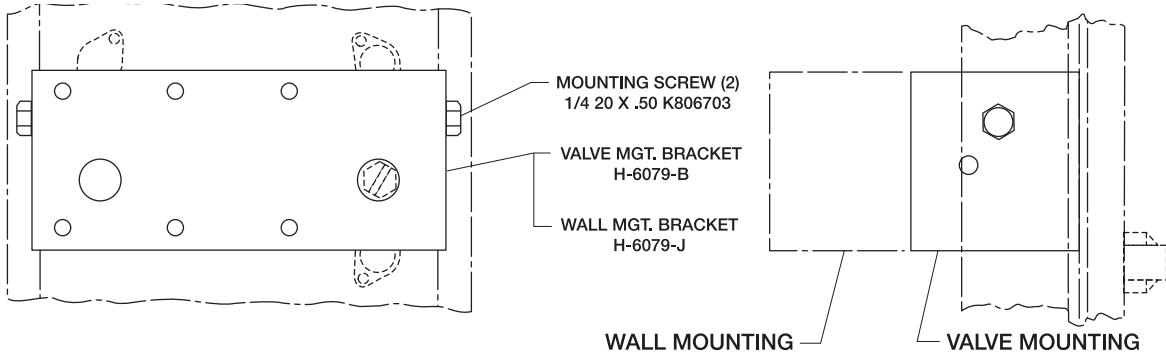

DRIPWELL FILTER REGULATOR

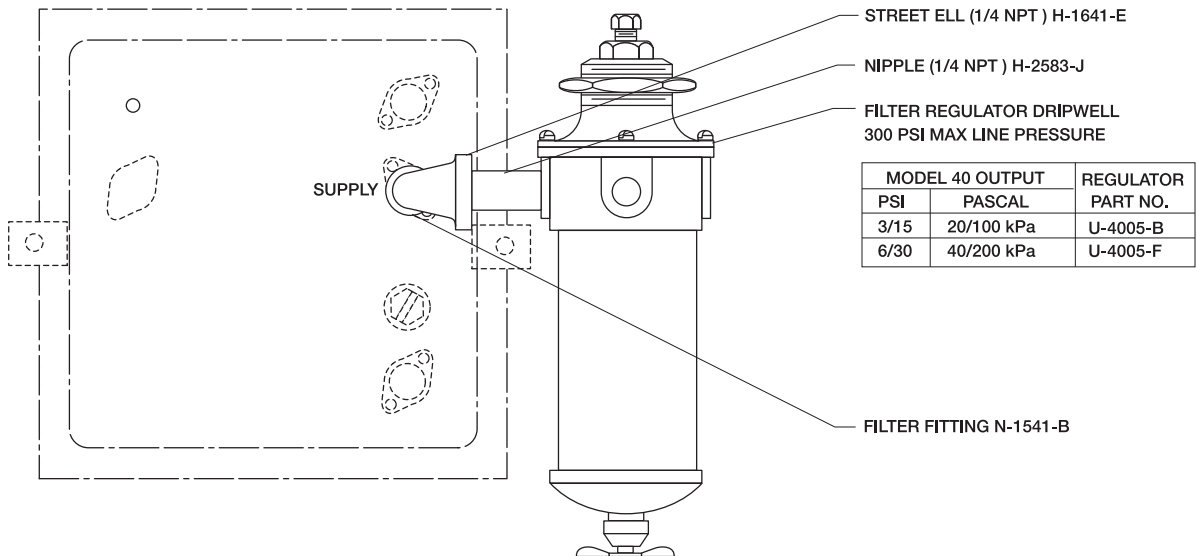



D/P CONTROLLER
OUTLINE DIMENSIONS

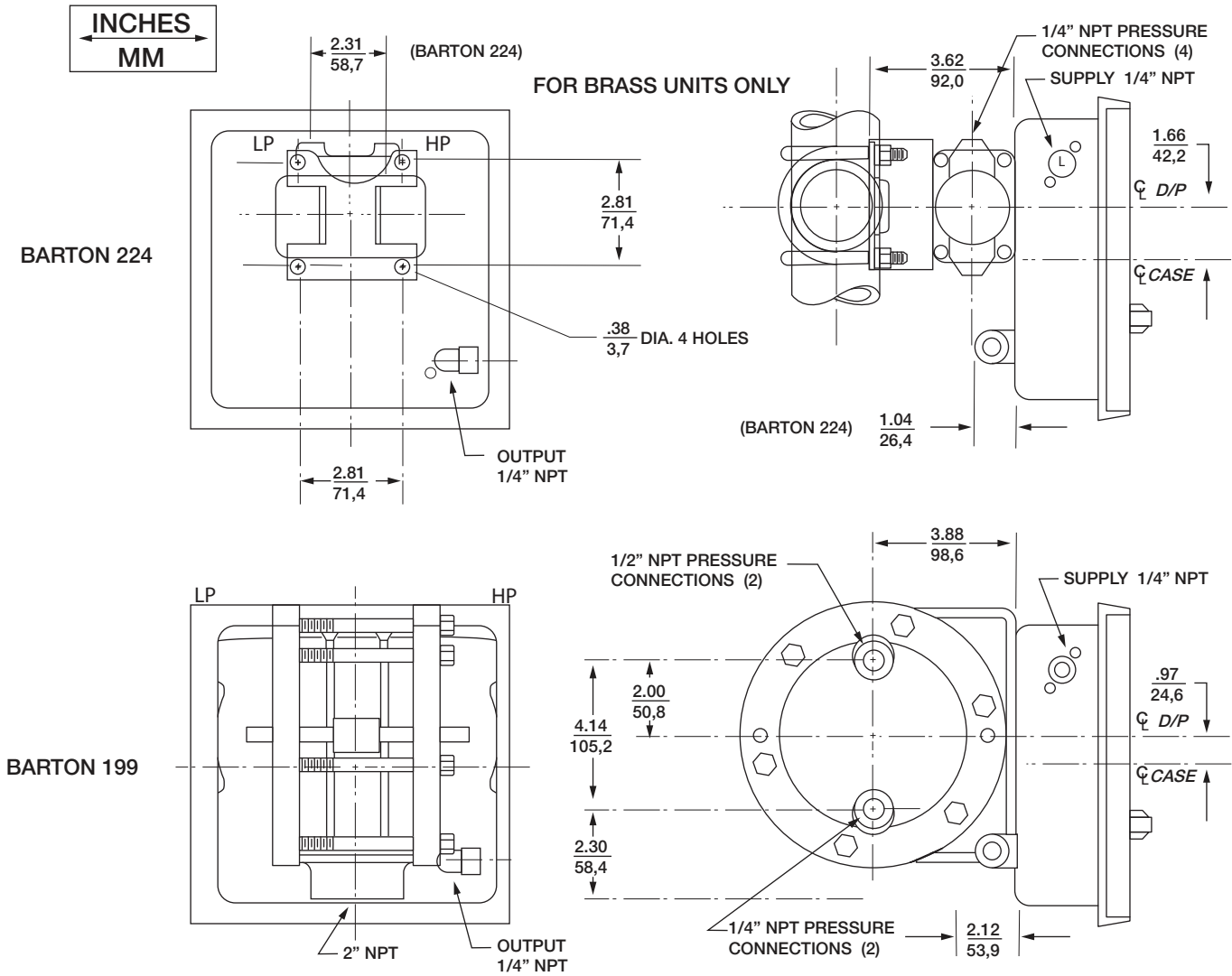



User Manual



Order e-mail: mctpmt.sales@ametek.com

Sales/Technical Support: +1 215-674-1234 | 205 Keith Valley Road | Horsham, PA 19044 U.S.A.

© AMETEK, Inc. All rights reserved.

Printed in the U.S.A.

K796131 REV. G 05/2023

Specifications are subject to change without notice. Visit our Web site for the most up-to-date information.

www.ametekusg.com